

Profibus-DP Communication module CM-PDPV1

Frequency Inverter 230V / 400V

ACTIVE Cube



General points on the documentation

The present supplement of the documentation is valid for frequency inverters of the device series ACU 201/401. The information necessary for the assembly and application of the Profibus-DP communication module CM-PDPV1 is documented in this guidance.

For better clarity, the user documentation is structured according to the customer-specific demands made on the frequency inverter.

Brief instructions

The brief instructions manual "Quick Start Guide" describes the fundamental steps for mechanical and electrical installation of the frequency inverter. The guided commissioning supports you in the selection of necessary parameters and the software configuration of the frequency inverter.

Operating instructions

The operating instructions document the complete functionality of the frequency inverter. The parameters necessary for specific applications for adaptation to the application and the extensive additional functions are described in detail.

Application manual

The application manual supplements the documentation for purposeful installation and commissioning of the frequency inverter. Information on various subjects connected with the use of the frequency inverter are described specific to the application.

Installation instructions

As a complement to the brief instructions and the operating instructions, the installation instructions describe the installation and use of devices.

The documentation and additional information can be requested via your local representation of the firm of BONFIGLIOLI.

The following pictograms and signal words are used for the purposes of the present documentation:



Danger!

Danger refers to an immediate threat. Non-compliance with the precaution described will result in death, serious injury or material damage.



Warning!

Warning refers to a possible threat. Non-compliance with the warning may result in death, serious injury or material damage.



Caution!

Caution refers to an immediate hazard. Non-compliance may result in personal or material damage.

Attention!

Attention and the related text refer to a possible behavior or an undesired condition which can occur during operation.

Note

marks information that facilitates handling for you and supplements the corresponding part of the documentation.



Warning! In installation and commissioning, comply with the information in the documentation. You as a qualified person must read the documentation carefully before the start of the activity and obey the safety instructions. For the purposes of the instructions, "qualified person" designates a person acquainted with the installation, assembly, commissioning and operation of the frequency inverters and possessing the qualification corresponding to the activity.

Contents

1	General safety and application information	5
1.1	General information.....	5
1.2	Proper use.....	5
1.3	Transport and storage	6
1.4	Handling and installation.....	6
1.5	Electrical connection.....	6
1.6	Operating information	7
1.7	Maintenance and servicing	7
2	Introduction	8
3	Installation/Disassembly of the communication module.....	9
3.1	Installation	9
3.2	Disassembly	10
4	Socket connection/bus termination/line.....	11
5	Baud rate setting/line length.....	12
6	Setting the station address	12
7	LED indicators	13
8	Status Parameters.....	14
9	Error Behaviour	14
10	Setting PPO structure	15
10.1	Configuration process on the DP master.....	16
11	Commands SYNC/FREEZE.....	18
12	Available objects/scanning times.....	18
13	Handling of the objects.....	21
13.1	Parameter access via communication channel PKW	21
13.1.1	Request identification.....	22
13.1.2	Reply identification	22
13.1.3	Fault messages.....	22
13.1.4	Parameters, data set selection and cyclic writing	23
13.1.5	Sequence of communication	24
13.1.6	Examples of communication	25
13.2	Parameter access via the DP-V1 channel	27
13.2.1	Standard Mode.....	28
13.2.2	S7-compatible Mode	29
13.3	Process data channel.....	30
13.3.1	Data types of OUT/IN-objects.....	30
13.3.2	Profibus output sources (OUT-PZD x)	32
13.3.3	Profibus input parameters (IN-PZD x).....	33

13.4	Frequency conversion PDP word ← → inverter internal notation	35
13.4.1	PZD1, control word/state word	36
13.4.2	Control via contacts	37
13.4.3	Control via state machine	38
13.4.3.1	Behaviour in quick stop.....	42
13.4.3.2	Behaviour in transition 5.....	43
13.4.4	Control via remote contacts	44
13.4.5	PZD2, reference value/actual value	47
13.5	Actual value display of Profibus data	49
14	Parameter list	52
14.1	Actual values	52
14.2	Parameters	53
15	Annex	54
15.1	Warning messages	54
15.2	Fault messages	54
15.3	GSD File – BV__0B2C.GSD.....	55

1 General safety and application information

This documentation has been produced with the greatest of care and extensively and repeatedly checked. For reasons of clarity, not all the detailed information on all types of the product and also not every imaginable case of installation, operation or maintenance has been taken into account. If you require further information or if specific problems which are not dealt with extensively enough in the documentation exist, you can request the necessary information via the local representation of the company BONFIGLIOLI.

We would also point out that the contents of this documentation are not part of a previous or existing agreement, assurance or legal relationship and are not intended to amend the same. All obligations of the manufacturer result from the underlying purchase contract, which also contains the complete and solely valid warranty regulation. These contractual warranty provisions are neither extended nor limited by the production of this documentation.

The manufacturer reserves the right to correct or amend the contents and the product information as well as omissions without prior notification and assumes no kind of liability for damage, injuries or expenditure to be put down to the aforementioned reasons.

1.1 General information



Warning! BONFIGLIOLI VECTRON frequency inverters have high voltage levels during operation, depending on their protection class, drive moving parts and have hot surfaces.

In the event of inadmissible removal of the necessary covers, improper use, wrong installation or operation, there is the risk of serious damage to persons or property.

To avoid any damage, only qualified staff may carry out the transport, installation, setup or maintenance work required. Comply with the standards EN 50178, IEC 60364 (Cenelec HD 384 or DIN VDE 0100), IEC 60664-1 (Cenelec HD 625 or VDE 0110-1), BGV A2 (VBG 4) and national provisions. Qualified persons within the meaning of this principal safety information are people acquainted with the installation, fitting, commissioning and operating of frequency inverters and the possible hazards and in possession of qualifications matching their activities.

1.2 Proper use



Warning! The frequency inverters are electrical drive components intended for installation in industrial plants or machines. Commissioning and start of intended operation are not allowed until it has been established that the machine corresponds to the provisions of the EC machine directive 98/37/EEC and EN 60204. According to the CE sign, the frequency inverters additionally fulfill the requirements of the low-voltage directive 2006/95/EC and standards EN 50178/DIN VDE 0160 and EN 61800-2. Responsibility for compliance with the EMC directive 89/336/EEC is with the user. Frequency inverters are available in a limited way and as components exclusively intended for professional use within the meaning of the EN 61000-3-2.

With the issue of the UL according to UL508c, the requirements of the CSA Standard C22.2-No. 14-95 have also been fulfilled.

The technical data and the information on connection and ambient conditions the rating plate and the documentation be complied with. The instructions must be read and fully understood before starting work on the device.

1.3 Transport and storage

Transport and storage are to be carried out in an adequate way in the original packaging. Storage shall be in dry rooms protected against dust and moisture with slight temperature fluctuations. Please observe the climatic conditions according to EN 50178 and the marking on the packaging. The duration of storage without connection to the admissible reference voltage may not exceed one year.

1.4 Handling and installation



Warning! Damaged or destroyed components may not be put into operation because they may be a health hazard.

The frequency inverters are to be used according to the documentation, the directives and the standards. Handle carefully and avoid mechanical overload. Do not bend the components or change the isolation distances. Do not touch electronic components or contacts. The devices contain electrostatic sensitive components which can easily be damaged by improper handling. Any use of damaged or destroyed components shall be considered as a non-compliance with the applicable standards. Do not remove any warning signs from the device.

1.5 Electrical connection



Warning! Before any assembly or connection work, de-energize the frequency inverter. Make sure that the frequency inverter is de-energized. Do not touch the sockets, because the capacitors may still be charged. Comply with the information given in the operating instructions and on the frequency inverter label.

While working on the frequency inverters, obey the applicable standards BGV A2 (VBG 4), VDE 0100 and other national directives. Comply with the information in the documentation on electrical installation and the relevant directives. Responsibility for compliance with and examination of the limit values of the EMC product standard EN 61800-3 for variable-speed electrical drive mechanisms is with the manufacturer of the industrial plant or machine.

The documentation contains information on installation correct for EMC. The cables connected to the frequency inverters may not be subjected to an isolation test with a high test voltage without previous circuit measures.

1.6 Operating information



Warning! The frequency inverter may be connected to power supply every 60 s. Consider this for a jog operation of a mains contactor. For commissioning or after an emergency stop, a non-recurrent, direct restart is permissible. After a failure and restoration of the power supply, the motor may start unexpectedly if the AutoStart function is activated. Install protective equipment if personal injury or material damage is possible.

Before commissioning and the start of the intended operation, attach all the covers and check the sockets. Check additional monitoring and protective devices pursuant to EN 60204 and the safety directives applicable in each case (e.g. Working Machines Act, Accident Prevention Directives etc.).

No connection work may be performed, while the system is in operation.

1.7 Maintenance and servicing



Warning! Unauthorized opening and improper interventions can lead to physical injury or damage to property. Repairs on the frequency inverters may only be carried out by the manufacturer or persons authorized by the latter. Check protective equipment regularly.

2 Introduction

This document describes the features of the Profibus-DP communication module CM-PDPV1 for frequency inverters of the ACU series.

For the Profibus-DP connection, the frequency inverter must be equipped with the Profibus-DP communication module CM-PDPV1. The Profibus component CM-PDPV1 is enclosed with the inverter as a separate part and must be fitted by the user. This is described in the chapter "Installation".

Note: These instructions are not to be understood as fundamental information on the Profibus-DP. They presuppose underlying knowledge of the methods and modes of effect of the Profibus-DP on the part of the user. In some points, setting and display possibilities are described alternatively to the control unit KP500 via the VPlus PC program. Operation of a PC with the VPlus program on the frequency inverter with use of the Profibus component CM-PDPV1 is only possible via an optional interface adapter KP232 on the slot of the control unit KP500.

The Profibus component CM-PDPV1 has the **ident number 0x0B2C** (hexadecimal). The device's data set file has the designation **BV__0B2C.GSD** and is attached to the appendix of this documentation. The identification number and designation of the GSD file have been assigned by the Profibus user organization in Karlsruhe Germany.

Attention! With the help of the Profibus-DP communication module CM-PDPV1 it is possible to access **ALL** parameters of the frequency inverter from the external control unit. Control of the access via the Control Level (Parameter 28) as with the control unit KP500 or the VPlus PC software does not exist. A change of parameters with an unknown meaning to user can lead to the inoperability of the frequency inverter.

3 Installation/Disassembly of the communication module

3.1 Installation

The communication module is pre-assembled in a case. Additionally, a PE spring is enclosed for PE connection (shield).



Caution! The frequency inverter must be disconnected from the power supply before installation of the communication module. Assembly under voltage is not permissible and will destroy the frequency inverter and/or the communication module. Do not touch the PCB visible on the back of the module, otherwise components may be damaged.

Work steps:

- Disconnect the frequency inverter from the mains voltage and protect it against being energized unintentionally.
- Remove covers (1) and (2) of the frequency inverter. Slot B (4) for the communication module is now accessible.

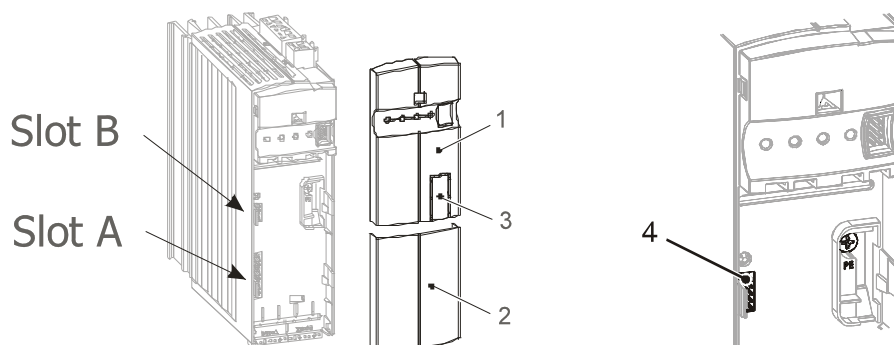

- Mount the supplied PE spring (5) using the M4 screw (6) in the unit. The spring must be aligned centrally.
- Insert the communication module in slot B (4) until it engages audibly.
- Fix the communication module by screwing the M2 screw (7) of the module to the PE spring (5).

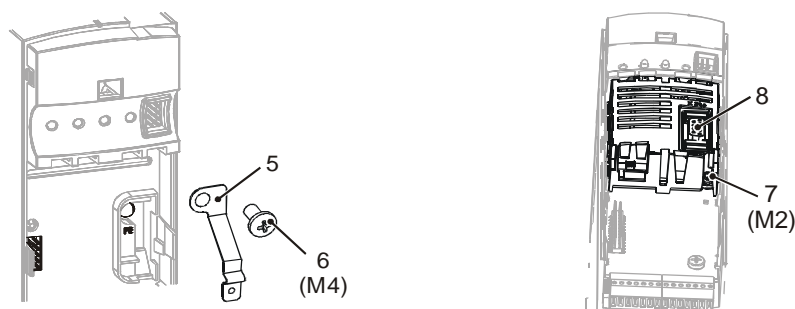

- In the upper cover (1), break out the pre-punched cutout (3) for the plug X310 (8).
- Mount the two covers (1) and (2).

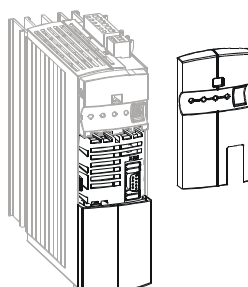

3.2 Disassembly

- Disconnect the frequency inverter from mains voltage and protect it against being energized unintentionally.
- Remove covers (1) and (2) of the frequency inverter.

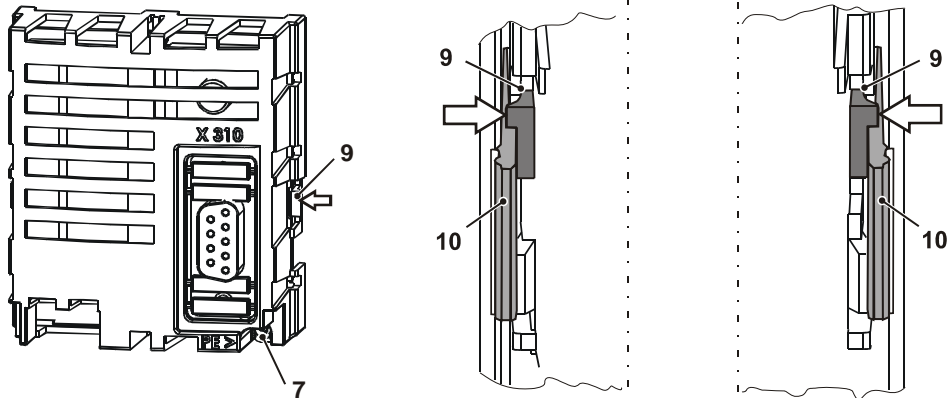

- Loosen the M2 screw (7) on the communication module
- Unplug the communication module from Slot B (4) by unlocking the locking hooks (9) on the right and left hand side of the module from the case of the frequency inverter using a small screwdriver.
The locking hooks (9) are located at the place where the locking hooks (10) for the upper cover (1) project from the case of the frequency inverter.
 - To do this, carefully insert the screwdriver in the gap between the case of the module and the frequency inverter and push the locking hook inwards in the direction of the arrow (←). As soon as the right hand side is unlocked, pull the module out a bit on the right hand side and hold it.
 - Hold the module on the right hand side while unlocking the locking hook on the left hand side in the same way (⇒).
 - Pull the module out of the slot by gently pulling on the right and left hand side alternately.
- Disassemble the PE spring (5).
- Mount the two covers (1) and (2).

4 Socket connection/bus termination/line

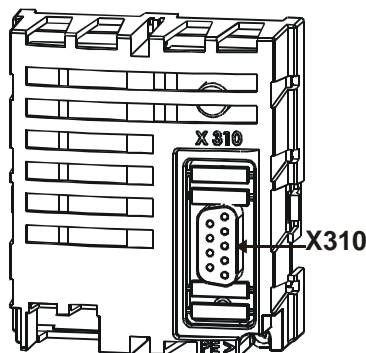

The bus socket **X310** (9-pole Sub-D) is connected according to the Profibus DP standard EN50170.

Please take the details for the pin allocation of the bus plug from the following table.

The bus termination necessary on the bus line in the physically first and last subscriber can be activated via corresponding circuits in the bus connection sockets (e.g. built by Siemens).

- Attention!** The device(s) will only communicate with the master if
- The master is connected to the mains (or powered by DC 24V)
 - The unit is connected to the mains (or powered by DC 24V)
 - The first and the last subscriber on the connected branch have a correctly set bus termination
 - All other devices in between have no bus termination or a deactivated bus termination.

Bus plug X310		
Pin	Name	Function
housing	screen	connected with PE
1	PE	PE
2	not used	-
3	RxD/TxD-P	positive signal RxD/TxD-P, corresponding to RS485 B-Line
4	CNTR-P	control signal for repeater
5	DGND	isolated ground for bus connection
6	VP	isolated 5V for bus connection
7	not used	-
8	RxD/TxD-N	negative signal RxD/TxD-N, corresponding to RS485 A-Line
9	not used	-

Only admissible types are to be used for the bus socket. They must all be suited for the 12 MBaud transmission rate.

This is, for example, type **Profibus connector 12 MBAUD** (6ES7 972-0BA11-0XA0) from Siemens.

Only admissible types are to be used as a line for the Profibus (line type A).

This is, for example, type **UNITRONIC-BUS L2/F.I.P. 1x2x0,64** from Lappkabel.

Attention! The line screen is to be connected to ground (PE) on both sides with good conductivity.

5 Baud rate setting/line length

The baud rate is not explicitly set. The Profibus component supports the **Auto_Baud** function and independently determines the baud rate set on the bus.

The maximum line length recommended by the PNO correlates to the Baud rate.

Profibus-DP interface	
Baud rate/kBaud	max. line length/m
9.6	1200
19.2	1200
45.45	1200
93.75	1200
187.5	1000
500	400
1500	200
3000	100
6000	100
12000	100

6 Setting the station address

A maximum of 125 slave frequency inverters can be operated on the Profibus-DP. Each frequency inverter is assigned a node ID for its unambiguous identification; this ID may only exist once in the system. The setting of the node ID is carried out via parameter *Profibus Node-ID 391*.

Parameter		Setting		
No.	Description	Min.	Max.	Fact. sett.
391	Profibus Node-ID	-1	126	-1

Note: *Profibus Node-ID 391* = -1 means Profibus function **switched off**.

7 LED indicators

The communication module has two bicolor LEDs which display the module status and the (Profibus) operation mode.

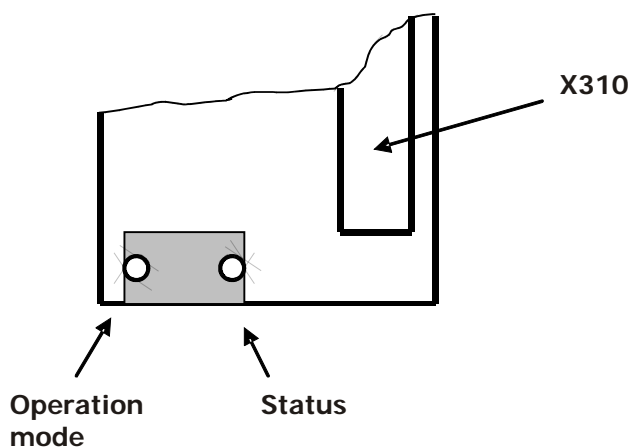

Operation Mode	
state	indication
Off	not online/no power
Green	online, data exchange
Flashing Green	online clear
Flashing Red (1 flash)	parameterisation error
Flashing Red (2 flashes)	configuration error (*)

(*) configuration error

The configuration error indicates an incorrect configuration of the data exchange object. See chapter "Configuration process on the DP master".

Status	
state	indication
Off	not initialised/no power
Green	initialised
Flashing Green	initialised, diagnostic event present (*)
Red	exception error (**)

(*) diagnostic event

When the inverter enters the error state a diagnostic event is sent from the inverter controller to the CM-PDPV1. The CM-PDPV1 then sends a diagnostic message to the Profibus master. The Profibus master device is then able to display the inverter error. The LED stops flashing after the acknowledgement of the inverter error.

Note: Diagnostic events are handled by a S7-CPU with OB82/OB86. If these objects are NOT loaded the CPU enters the STOP state in the case of a diagnostic event.

(**) exception error

An exception error indicates a fatal error on the CM-PDPV1 or communication loss between CM-PDPV1 and inverter controller. Check the inverter error message (with KP500 or KP232 and VPlus).

8 Status Parameters

The Profibus module CM-PDPV1 has two actual value parameters which display the current status of the module itself as well as that of the controlling software in the inverter.

Status Control 365 displays the software state of the the controlling software in the inverter.

Status Fieldbus Module 366 displays the module state.

The *Status Control 365* and *Status Fieldbus Module 366* show the following states during operation.

<i>Status Control 365</i>	Description
Wait_Process_PDP	Waiting for connection to Profibus master
Wait_Process2_PDP	Waiting for reconnection to Profibus master after connection loss
Process_Active_PDP	Connection to Profibus master established, Data-Exchange with Profibus master running

<i>Status Fieldbus Module 366</i>	Description
WAIT_PROCESS	Waiting for connection to Profibus master
PROCESS_ACTIVE	Connection to Profibus master established, Data-Exchange with Profibus master running

These parameters can show other messages that are usually not of interest. These messages are of interest for Bonfiglioli Vectron support in the case of problems and trouble shooting.

9 Error Behaviour

In the event of Profibus errors (e. g. Profibus OFF), the behaviour of the inverter can be set with *Profibus Error Reaction 393*.

Parameter		Setting		
No.	Description	Min.	Max.	Fact. Sett.
393	Profibus Error Reaction	0	3	1

Operation mode 393	Function
0 - No Reaction	Inverter remains in the current state.
1 - Error	Inverter enters error state.
2 - Coast to Stop	Inverter power stages are switched off and drive stops in free run.
3 - Quick Stop	Drive is decelerated with quick stop ramps.

Note: The operation modes "2 - Coast to Stop" and "3 - Quick Stop" are only available when *Local/Remote 412* is set to "1 - Control via Statemachine".

10 Setting PPO structure

As a function of the application in question, various process peripheral objects (PPOs) with differing lengths and contents are used for data exchange. The CM-PDPV1 offers a wide range of PPO settings. With the help of a hardware configuration tool the user is able to construct PPO settings as needed for his application.

Four predefined objects PPO1, PPO2, PPO3 and PPO4 and two additional objects (communication object PKW, process data object PZD) are available for free configuration.

The required object is to be set on the DP master in the hardware configuration. There is no setting for the required object on the side of the frequency inverter, it sets itself automatically to the projected object.

Profibus - Objects		
Object	Objects length/Bytes	Objects length/Words
PPO 1	12	6
PPO 2	20	10
PPO 3	4	2
PPO 4	12	6
PKW	8	4
PZD	4	2

Note: Further information on the contents of the objects is described in the chapter 13 "Handling of the objects".

The PKW object is used for accessing parameters (read/write) in the inverter. This object causes additional busload because it sends its contents with every data exchange cycle, whether it is used or not. As an alternative function without the necessity of the PKW object, the CM-PDPV1 module supports the DP-V1 channel. This function is explained in chapter 13.2 "Parameter access via the DP-V1 channel".

Each PZD object has two words of input/output data. The handling of this object is explained in chapter 13.3.1 "Data types of OUT/IN-objects".

10.1 Configuration process on the DP master

The configuration process of the frequency inverter with the Profibus communication module CM-PDPV1 is shown here using the example of a Siemens STEP7 hardware configurator. The process is principally valid for other configurations in an equivalent form.

First, the GSD file BV__0B2C.GSD is installed in the hardware configuration tool (if not already existent). This is done with the menu selection **Extras\Install new GSD**. Here, you enter the path and the name for the GSD file (BV__0B2C.GSD).

If the GSD file has been installed, the frequency inverter appears under the selection

PROFIBUS-DP \ Further FIELD DEVICES \ Drives \ ACTIVE-DPV1

From this position, a frequency inverter **ACTIVE-DPV1** can be connected to the Profibus by Drag & Drop.

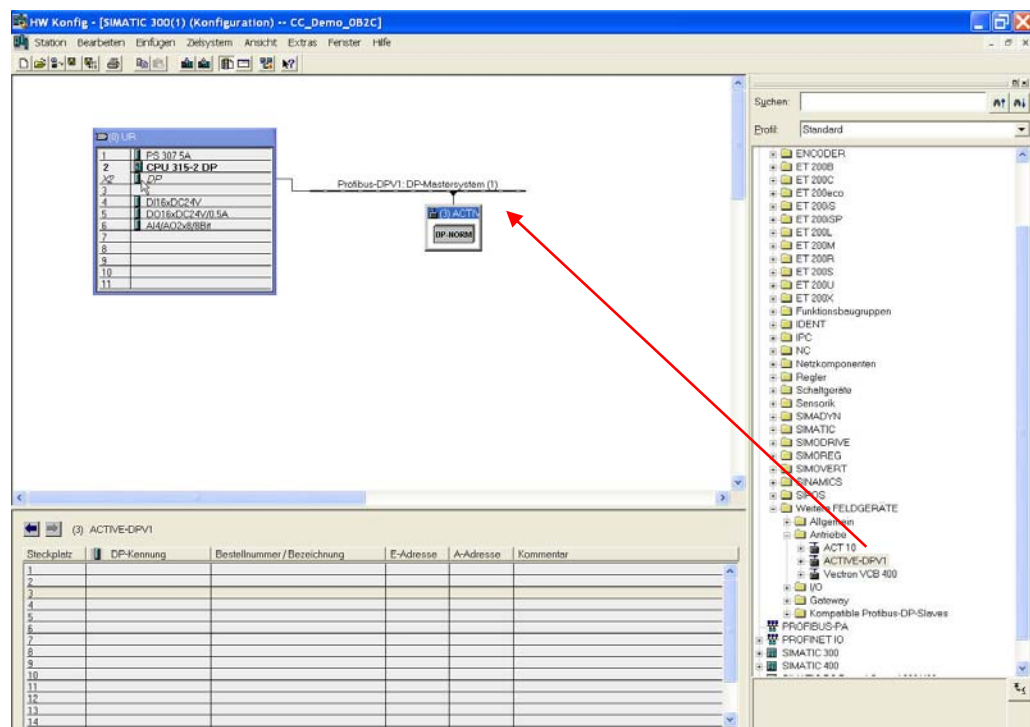

The six possible objects PPO1 to PPO4 and PKW, PZD are visible under the menu item **ACTIVE-DPV1**. The required object is now assigned to the inverter by Drag & Drop.

The screen shot from the STEP7 hardware configuration shows a frequency inverter with station address 3 and a custom-specific configuration.

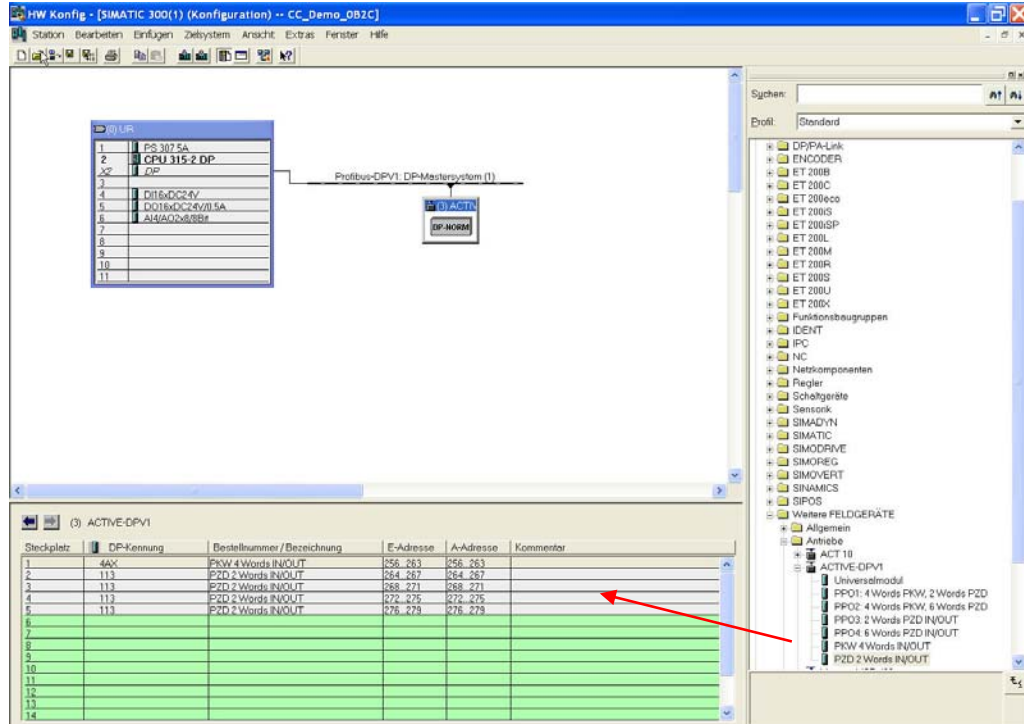

The above configuration setting is:

- 1 PKW object 8 bytes or 4 words, communication object (input/output)
- 4 PZD objects 16 bytes or 8 words, process data objects (input/output)

Note:

- The data direction IN/input and OUT/output is from the master's point of view.
- Every single configured PZD object results in two word (4 byte) objects PZDn PZDn+1 for both input and output.
- The CM-PDPV1 offers four predefined objects (PPO1...4) to be compatible to the former CM-PDP and two additional objects PKW (communication channel) and PZD (process data) for application specific configurations.

Restrictions for user defined configuration settings:

- The PKW object is allowed only once as the first object.
- As a minimum one PZD object must be configured.
- The resulting number of all objects must be less than or equal to 36 bytes (18 words).

Note: A restriction violation results in a configuration error message from the PLC on the Profibus start up cycle. Also the Operation Mode Led on the CM-PDPV1 flashes red (2 flashes).

11 Commands SYNC/FREEZE

The Profibus component supports the Profibus commands SYNC/UNSYNC and FREEZE/UNFREEZE. These commands are used to synchronize a number of slaves.

With the FREEZE command, all the slaves keep their input data. They are then read out in sequence by the bus master. As all the slaves keep their inputs simultaneously with the FREEZE command, the bus master is given a process pattern of all the slaves at a defined time. With the UNFREEZE command, this state is cancelled and the slaves update their inputs again.

With the SYNC command, all the slaves retain their current outputs. Subsequently arriving data are not put through to the outputs, but buffered. The bus master can give new commands to the slaves and activate all the slaves simultaneously with the UNSYNC command. They immediately transfer the buffer data to their outputs with the UNSYNC command.

12 Available objects/scanning times

If a Profibus slave has been recognized, parameterised and configured by its master on the bus, there is a cyclic exchange of data with the Profibus **DATA_EXCHANGE** service, in which the output data are transmitted from the master to the slave and the input data from the slave to the master **in one cycle**. The repetition rate with which the slaves carry out the exchange of data with the master, the so-called bus rotation time, is a function of the transmission rate, the number of subscribers and the size of the objects transmitted. If there are few subscribers, a high transmission rate and short objects being exchanged, bus rotation times of 1 to 2 ms are possible.

It is therefore sensible to configure the objects to suit the application. Depending on the application the focus can be transmission speed, number of objects or a combination of both.

The configured data exchange objects have principally two components, which are either completely, partly or not at all existent with the differing object configurations. These components are the communication channel and the process data channel.

The **communication channel** (PKW object) is used for accessing (write/read) parameters in the frequency inverter. An exception is formed by the string parameters, to which there is NO access. The communication proceeds according to a firmly defined hand-shake process and lasts for a number of DATA_EXCHANGE cycles.

The **process data channel** (PZD objects) is processed in every cycle. The reference values are accepted and the actual values forwarded. Therefore a data update takes place with every DATA_EXCHANGE.

Direction of transmission Master → Slave (OUT)

communication channel				process data channel					
PKW area				PZD area					
PKE	IND	PWE	PWE	PZD 1	PZD 2	PZD x	PZD x	PZD x	PZD x
		PWEh	PWEI	STW	HSW	Outx	Outx	Outx	Outx

PKW Parameter identification value

PZD Process data channel STW = Control word HSW = Main reference value

Outx = user defined

Direction of transmission Slave → Master (IN)

communication channel				process data channel					
PKW area				PZD area					
PKE	IND	PWE	PWE	PZD 1	PZD 2	PZD x	PZD x	PZD x	PZD x
		PWEh	PWEI	ZSW	HIW	Inx	Inx	Inx	Inx

PKW Parameter identification value

PZD Process data channel ZSW = State word HIW = Main actual value

Inx = user defined

Consistency area

communication channel				process data channel					
PKW object				PZD objects					
PKE	IND	PWE	PWE	PZD 1	PZD 2	PZD x	PZD x	PZD x	PZD x
full length				word	word	word	word	word	word

The consistency area describes the parts of the object which must have consistent contents. The consistency states are encrypted in the configuration data of the GSD file and have effects on the possible access mechanisms on the part of the DP master. In this way, the 8 bytes of the communication channel in a PLC of type Siemens S7 can only be reached via the special functions **SFC14 (DPRD_DAT)** and **SFC15 (DPWR_DAT)**. The words of the process data channel are directly addressable as **periphery input/output words (PEW, PAW)**.

	communication channel				process data channel					
	PKE	IND	PWEh	PWEI	PZD1	PZD2	PZD3	PZD4	PZD5	PZD6
PPO1										
PPO2										
PPO3										
PPO4										

PPO1 ... PPO4 are predefined configurations. With the help of the PZD- and PKW-objects you are able to build your own application specific configuration.

- The communication channel is always treated identically. This is valid for the predefined configurations PPO1/PPO2 and custom specific configuration with communication object PKW.
- The process data channel objects PZD1/PZD2 are firmly defined and its contents cannot be altered. This definition is also valid for user defined configurations.
- The contents of process data channels PZD3 to PZD 18 (maximum, without communication channel PKW !) is user defined.

Note: In the data transmission, the **Motorola format** is presupposed for the position of Low/High byte first, as is also supported by a PLC of the type Siemens S7. If the DP master supports the Intel format, Low/High byte are to be swapped on the master side before transmission and after receipt.

Scan time

Scan time defines the data update cycle between the Profibus module CM-PDPV1 and the inverter's controller which processes the Profibus data. This scan time is independent of the bus rotation time.

Regardless of the transmission speed on the Profibus, the scanning time of the inverter is a function of the configured objects and the resultant object length (number of bytes).

No. of configured		Scan time
bytes	words	Controller/CM-PDPV1 [ms]
Inverter ACU		
4	2	2
8	4	2
12	6	2
16	8	2
20	10	2
24	12	2
28	14	2
32	16	2
36	18	4

The scan time is dependent on the number of configured objects.

13 Handling of the objects

13.1 Parameter access via communication channel PKW

The communication channel (PKW area) has the following structure:

Designation	PKW Area							
	PKE		IND		PWE-high		PWE-low	
Content	Parameter identification		Index		Parameter value High-Word		Parameter value Low-Word	
	High Byte	Low Byte	High Byte	Low Byte	High Byte	Low Byte	High Byte	Low Byte
			data set	SB				
Byte No.	0	1	2	3	4	5	6	7

The data is transmitted in the **Motorola format** as, for example, supported by the S7 PLC from Siemens. Thus, the high byte is on the lower byte of the telegram and the low byte on the higher byte.

Note: The data set is always on the high byte of "Index" (data set/Byte No. 2). If the System bus function is available (EM-module with Systembus) a Systembus address is set on the low byte of "Index" (SB/Byte No. 3). With the help of this parameter the access to a Systembus subscriber is possible. For details see the Systembus manual.

Structure of the parameter identification (PKE):																
PKE	High Byte								Low Byte							
Bit	15	14	13	12	11	10	9	8	7	6	5	4	3	2	1	0
	AK				SPM	PNU										

AK: Request or reply identification (value range 0 ..15)

SPM: Toggle bit for spontaneous result processing

PNU: Parameter number (value range 1 to 1599)

- The request and reply identifications are stored in the AK area. If no parameter processing is to be carried out, the **"no request"** type of function is to be set.
- With bit 11 (SPM), the readiness for spontaneous report processing can be switched on and off (0 = OFF, 1 = ON, in the present application, the spontaneous report processing is not supported, so SPM is always 0).
- The PNU area transmits the number of the parameter to be processed.

Parameter values (= data) of the type Integer/Unsigned Integer (16 Bit) and Long (32 Bit) can be written and read. The data type is specified in the request identification. In data set change-over capable parameters (array), the required data set is stated in the Index Byte (Byte 2).

Note: An Excel file, which is available on request, exists for the necessary information on the parameters with regards to the data type and data set change-over capability.

Note: To obtain access to the PKW object on a S7 PLC the functions SFC14/15 must be used.

13.1.1 Request identification

Structure of the request identification AK (output data set, Master → Slave)

Request identification AK	Data type	Function
0	-	no request
1	int/uint , long	read parameter value
2	int/uint	write parameter value int/uint
3	long	write parameter value long
6	int/uint , long Array	read parameter value Array
7	int/uint Array	write parameter value int/uint Array
8	long Array	write parameter value long Array

Array: Applies to data set change-over capable parameters; the required data must be specified in data set/INDEX. Otherwise, data set/INDEX = 0.

13.1.2 Reply identification

Structure of the reply identification AK (input data set, Slave → Master)

Reply identification AK	Data type	Function
0	-	no request
1	int/uint	transmit parameter value int/uint
2	long	transmit parameter value long
4	int/uint Array	transmit parameter value int/uint Array
5	long Array	transmit parameter value long Array
7	-	request cannot be implemented
8	-	no control sovereignty for PKW interface

- If the reply identification = 7 (request cannot be implemented), an error code is inserted in PWE low (Byte 6/7).
- If the reply identification = 8 (no control sovereignty), the master has no writing right to the slave.

13.1.3 Fault messages

Coding of the fault messages in the reply data set PWE Low/Low Byte at Byte 7 (Slave → Master):

Fault No. (dec.) acc. to PROFIDRIVE	Meaning
0	Inadmissible parameter number PNU
1	Parameter value cannot be altered
2	Lower or upper parameter value limit exceeded
3	Faulty data set
4	No data set change-over capable parameter
5	Wrong data type
18	Other fault
Extension	Meaning
101	Parameter cannot be read
103	Fault occurred in reading the EEPROM
104	Fault occurred in writing the EPROM
105	Check sum fault in EEPROM occurred
106	Parameter may not be written in operation
107	Values of the data sets differ
108	Unknown request

13.1.4 Parameters, data set selection and cyclic writing

Parameters to be set can be taken from the parameter list referring to the configuration of the standard operating instructions. In the parameter list, state whether a parameter is data set change-over capable (data set/INDEX = 1 to 4) or only exists once (data set/INDEX = 0).

The parameter list also provides information on the display format of a parameter and its type (int/uint/long). String parameters cannot be transmitted due to the possible number of bytes.

The values transmitted are always integer values. For values with decimal places, the decimal point is not transmitted.

The word IND passes on the required data set of the parameter. In the present application, the data set number 0 is assigned to existing parameters; a selection from multiple (data set change-over capable) existing parameters is carried out by inserting a number from 1 to 4.

The actual parameter value is transmitted in the PWE area; as a 16 Bit value (int/uint) it occupies PWEI, as a 32 Bit value (long) PWE high and PWE low, with the high word located in PWE high.

If parameters with four data values are set via data set = 0, all four data sets are set to the same transmitted value. A read access with data set = 0 to such parameters is only successful if all four data sets are set to the same value. If this is not the case an error is reported.



Caution! The values are entered automatically into the EEPROM on the controller. If values are to be written cyclically with a high repetition rate, there must be no entry into the EEPROM, as it only has a limited number of admissible writing cycles (about 1 million cycles). If the number of admissible writing cycles is exceeded, the EEPROM is destroyed.

To avoid this, cyclically written data should be transmitted into the RAM (only without a writing cycle onto the EEPROM). Then the data are not stored secure against zero voltage and must be written again after a Power off/on.

This mechanism is activated by the target data set being increased by five in the specification of the data set (IND).

Entry only into the RAM:	
EEPROM	RAM
Entry into data set 0	Data set (IND) = 5
Entry into data set 1	Data set (IND) = 6
Entry into data set 2	Data set (IND) = 7
Entry into data set 3	Data set (IND) = 8
Entry into data set 4	Data set (IND) = 9

Writing access to data set change-over capable parameters is to be considered as a further special point. If the values of a data set change-over capable parameter are to be set to the same value in all data sets, the parameter can be written via the data set (IND) 0.

13.1.5 Sequence of communication

A request from the master is **always** answered with a reply from the slave. Each PPO can only accept one request or one reply at a time. In this way, a defined hand-shake procedure between master and slave must be complied with.

In the initial situation, the request **and** reply identification must = 0. The master sets its request identification and waits for the slave to change the reply identification from 0 to $\neq 0$. Now, the reply from the slave is available and can be evaluated. Thereupon, the master sets its request identification = 0 and waits for the slave to change the reply identification from $\neq 0$ to 0. With this, the communication cycle is completed and a new one can start.

Attention! The slave only replies to new requests if it has reacted to the request identification = 0 with the reply identification = 0.

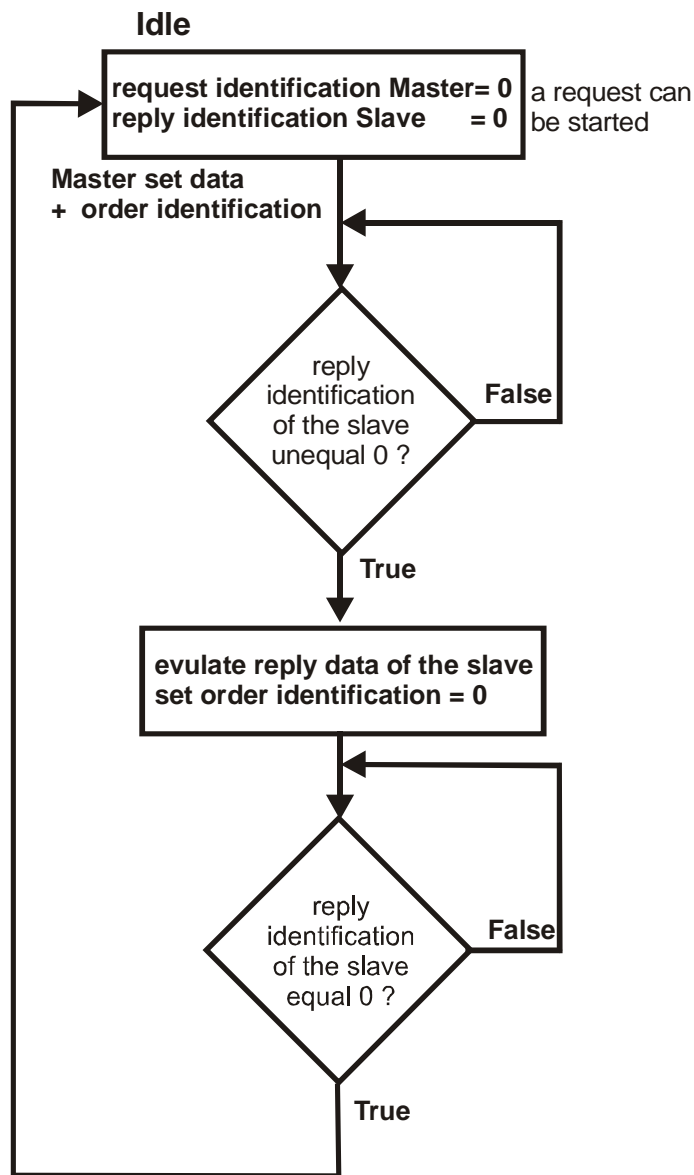

13.1.6 Examples of communication

Parameter					Setting		
No.	Description	Type	Write / Read	Format	Min.	Max.	Fact. Sett.
400	Switching frequency	P-W	S/L	x	1	8	2
480	Fixed frequency 1	P[I]-D	S/L	xxxx.xx Hz	-999.00	999.00	5.00

Parameter 400 is one word (P-W), int, not data set switch-over capable and is to be read.

Request from Master:

AK = 1 (request identification = read parameter value)
 PNU = 400 (= 0x190)
 IND = 0
 PWEh = 0
 PWEI = 0

PKW area								
Designation	PKE		IND		PWE high		PWE low	
Content	Parameter identification		Index		Parameter value High Word		Parameter value Low Word	
	High Byte	Low Byte	High Byte	Low Byte	High Byte	Low Byte	High Byte	Low Byte
	0x11	0x90	0	0	0	0	0	0
Byte No.	0	1	2	3	4	5	6	7

Reply from Slave:

AK = 1 (reply identification = transmit parameter value int/uint)
 PNU = 400 (= 0x190)
 IND = 0
 PWEh = 0
 PWEI = value

PKW area								
Designation	PKE		IND		PWE high		PWE low	
Content	Parameter identification		Index		Parameter value High Word		Parameter value Low Word	
	High Byte	Low Byte	High Byte	Low Byte	High Byte	Low Byte	High Byte	Low Byte
	0x11	0x90	0	0	0	0	0	Wert
Byte No.	0	1	2	3	4	5	6	7

Parameter 480 is a double word (P[I]-D), long, data set change-over capable, and is to be written. The target data set is data set 3.

Reference value = -300.00 Hz (-30000 is transmitted)

The negative value is portrayed as follows in accordance with integer arithmetic:
0xFFFF8AD0

Request from Master:

AK = 8 (request identification = write parameter value long Array)
 PNU = 480 (= 0x1E0)
 IND = 3
 PWEh = 0xFFFF
 PWEI = 0x8AD0

PKW area								
Designation	PKE		IND		PWE high		PWE low	
Content	Parameter identification		Index		Parameter value High Word		Parameter value Low Word	
	High Byte	Low Byte	High Byte	Low Byte	High Byte	Low Byte	High Byte	Low Byte
	0x81	0xE0	3	0	0xFF	0xFF	0x8A	0xD0
Byte No.	0	1	2	3	4	5	6	7

Reply from Slave:

AK = 5 (reply identification = transmit parameter value long Array)
 PNU = 480 (= 0x1E0)
 IND = 3
 PWEh = 0xFFFF
 PWEI = 0x8AD0

PKW area								
Designation	PKE		IND		PWE high		PWE low	
Content	Parameter identification		Index		Parameter value High Word		Parameter value Low Word	
	High Byte	Low Byte	High Byte	Low Byte	High Byte	Low Byte	High Byte	Low Byte
	0x51	0xE0	3	0	0xFF	0xFF	0x8A	0xD0
Byte No.	0	1	2	3	4	5	6	7

13.2 Parameter access via the DP-V1 channel

The Profibus communication module CM-PDPV1 provides the possibility to use the Profibus V1-channel. This is an alternative to the usage of the communication object PKW in the data exchange object. The PKW object is always sent on the bus, whether it is used or not, and therefore causes needless busload.

The V1 telegrams for parameter access are special Profibus telegrams that are sent only when a parameter access is necessary. Contrary to the usage of the PKW object, the V1 telegrams can access all types of parameters including string parameters.

To be compatible to different types of Profibus master devices there are two different methods included for the V1-channel. The behaviour of the CM-PDPV1 concerning the different methods is set with *DP-V1 Mode 329*.

Parameter		Setting		
No.	Description	Min.	Max.	Fact. Sett.
329	DP-V1 Mode	1	2	2

Operation mode		Function
1 - Standard	Standard usage of V1 channel	
2 - S7 compatible	S7 PLC usage of V1 channel	

Note: To get access to the V1-channel on a S7 PLC the functions SFC52/53 must be used.

The two different modes are necessary because V1 telegrams are handled differently on the various Profibus master implementations.

The standard telegram addresses a device by its Profibus node ID and selects the parameters by two 8 bit objects named *slot* and *index*. If the Profibus master device supports the direct setting of the Profibus node ID, *slot* and *index DP-V1 Mode 329* must be set to "1 – Standard" and the handling described for this setting must be used.

A S7 PLC uses two special functions SFC52/53 for the V1-channel. These functions do not offer an independent setting for node ID, *slot* and *index*. The addressing is accomplished by the diagnostic address (with *slot* always set to 0) of the device to be accessed. The only available and variable object for the PLC application is *index* (8 bit). If the Profibus master device does not support the setting of Profibus node ID, *slot* and *index DP-V1 Mode 329* must be set to "2 – S7 compatible" and the handling described for this setting is to be used.

For **both** types of DP-V1 Mode the **parameter data** to be read or written uses the **Motorola format**. The number of bytes depends on the parameter data type.

Parameter data types and byte order

Byte	0	1	2	3	4	5	max. 98
data type	uint/int								
content	high byte	low byte							
data type	long								
content	high byte	byte		low					
data type	string								
content	first char.								

uint/int = 2 bytes
long = 4 bytes
string = 1 ... 99 bytes

13.2.1 Standard Mode

A parameter is accessed by its parameter number and data set number. The valid range for parameter number is 0 ... 1599, the range of data set number is 0 ... 9.

Note: For the handling of data set selection see chapter "13.1.4 "Parameters, data set selection and cyclic writing".

The standard mode uses the direct setting of Profibus node ID, *slot* and *index*. With the setting of the two 8 bit objects *slot* and *index* the selection of parameter number and data set number for read/write is done. The number of bytes to be transferred (read/write) depends on the parameter's data type. In the case of a write cycle and an invalid number of bytes the CM-PDPV1 protocol reacts with an error message.

Calculation of slot and index:

Calculate an application data index **ADI** as a 16 bit unsigned integer with

$$\mathbf{ADI} = (\text{parameter number} + 1) + (2000 * (\text{data set number} + 1))$$

Calculate the value of *slot* and *index* with

$$\mathbf{slot} = (\mathbf{ADI} - 1) / 255$$

$$\mathbf{index} = (\mathbf{ADI} - 1) \text{ modulo } 255$$

Example:

parameter number = 480
data set number = 3

$$\mathbf{ADI} = (480 + 1) + (2000 * (3 + 1)) = 8481$$

$$\mathbf{slot} = (8481 - 1) / 255 = 33$$

$$\mathbf{index} = (8481 - 1) \text{ modulo } 255 = 65$$

The parameter data structure is explained above.

Access to Systembus:

The Standard Mode also offers a special functionality to obtain access to additional inverters via the Systembus. For example, there exists one inverter with CM-PDPV1 and several additional inverters coupled to the first one via the Systembus.

This function can be implemented with CM-PDPV1 via the virtual parameter **1600**. After power on/reset this virtual parameter **1600** is set to zero. With **1600** = 0 all parameter accesses by V1 channel are allocated to the inverter with CM-PDPV1 itself.

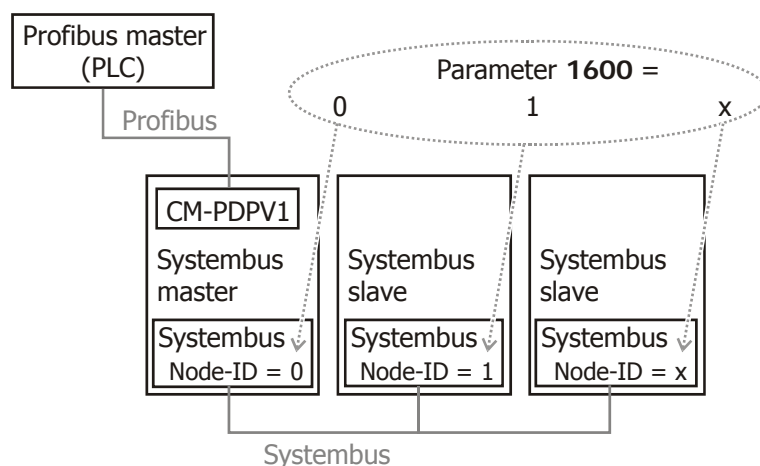

To obtain access to parameters of inverters via the Systembus, parameter **1600** is written to the desired Systembus node ID.

The data type of parameter **1600** is unsigned integer with a valid data range = 0 ... 63.

Parameter **1600** can be read and written.

13.2.2 S7-compatible Mode

A parameter is accessed by its parameter number and data set number. The valid range for parameter number is 0 ... 1599, the range of data set number is 0 ... 9.

Note: For the handling of data set selection see chapter 13.1.4 "Parameters, data set selection and cyclic writing".

The S7-compatible Mode only allows the setting of the object *index*. There are two steps necessary for reading/writing one parameter. The number of bytes to be transferred (read/write) depends on the parameter's data type. In the case of a write cycle and an invalid number of bytes the CM-PDPV1 protocol reacts with an error message.

Step 1:

In the first step the desired parameter number, data set number and Systembus node ID are written. This message is sent with *index set to 1*. The object to be sent has 4 bytes with the following structure:

data structure for index = 1:

Byte	0	1	2	3
content	parameter number		data set number	System bus address
	high byte	low byte		

Parameter number = 0 ... 1599

Data set = 0 ... 9

System bus address = 0 ... 63

Step 2:

The desired parameter data can now be read or written by sending a read or write request with *index set to 2*.

The parameter data structure is explained above.

13.3 Process data channel

In this chapter the handling of the PZDs is described. The mandatory process data objects PZD1/2 are described in chapters 13.4.1 "PZD1, control word/state word" and 13.4.5 "PZD2, reference value/actual value".

The PZD 3 ... 18 objects can be used in an application specific way. Inside the inverter these objects are represented as sources for PZD Out objects (data received from Profibus master) and input parameters for sources (data to be sent to the Profibus master).

Note: Input/output are defined from the Profibus master point of view.

13.3.1 Data types of OUT/IN-objects

Boolean data type

The valid value for boolean is FALSE/0x0000 and TRUE/0xFFFF.

data type – Boolean		
	boolean value	data content hexadecimal
OUT/IN-PZDn Boolean	FALSE	0x0000
OUT/IN-PZDn Boolean	TRUE	0xFFFF

n = 3 ... 18

Word data type

The Word data type can be used for percentage, current and torque variables. Current and torque are possible in applications with field-orientation. The scalings in question are described below.

Word data type – Percentage

The value range for percentage values is -300.00 to +300.00%. The values in OUT/IN-PZDn are displayed with a multiplication factor of 100.

Word data type – Percent			
	data content hexadecimal	data content decimal	logical interpretation
OUT/IN-PZDn Word	0x8AD0	- 30000	- 300.00 %
OUT/IN-PZDn Word	0x0000	0	0.00 %
OUT/IN-PZDn Word	0x7530	+ 30000	+ 300.00 %

n = 3 ... 18

Word data type – Current

For the current, calculation must be done in the device-internal scaling. The scaling is:

$$\text{Reference value} = (\text{Reference current}[A] / \text{scaling current}[A]) \cdot 2^{13}$$

$$2^{13} = 8192 \text{ (decimal)} = 0x2000 \text{ (hexadecimal)}$$

Word data type – Torque

For the torque specification, the calculation must be done in the device-internal scaling. The scaling for a torque value is identical to the specification of the reference current (see Current). If the machine is operated with nominal flux, a reference torque corresponds to a reference current.

Note: The equation stated for current (torque) applies for operation with nominal flux. If a machine is operated in the field weakening area, this is to be considered in the specification values.

If the current or torque variables are used, please take into account the device-specific scaling.

Long data type

The Long data type can be used for the frequency and position variables.

Frequencies use the internal notation of the inverter $(xxx \text{ Hz} / 4000 \text{ Hz}) * 2^{31}$.

Examples:

$$50.00 \text{ Hz} \rightarrow (50.00 / 4000.00) * 2^{31} = 0x01999999$$

$$-80.00 \text{ Hz} \rightarrow (-80.00 / 4000.00) * 2^{31} = 0xFD70A3D8$$

Position information depends on the settings of the motion control system. (Refer to the manual "Positioning".)

Long data type			
	data content hexadecimal	data content decimal	logical interpretation
OUT/IN-PZDx/y Long	0xnmmmmmm	Application-specific	Application-specific

x/y = 3/4, 5/6, ... 17/18

13.3.2 Profibus output sources (OUT-PZD x)

The table below lists the available output sources of the PZD Out objects. The content of the sources depends on the application. For the different data types the equivalent sources must be connected to the inverter input parameters.

- Note:**
- The availability of Out sources depends on the number of configured PZD objects.
 - Every configured PZD object consists of either two Boolean, two word or one long output object.
 - One PZD out object can be used for one data type only (depending on the application requirements).
 - The first configured PZD object (mandatory) represents the PZD1/2 with fixed contents and functions.

no. of configured PZD objects	Boolean Sources		Word Sources		Long Sources	
	name	src-no.	name	src-no.	name	src-no.
2	Out-PZD3 Boolean	640	Out-PZD3 Word	656	Out-PZD3_4 Long	672
	Out-PZD4 Boolean	641	Out-PZD4 Word	657		
3	Out-PZD5 Boolean	642	Out-PZD5 Word	658	Out-PZD5_6 Long	673
	Out-PZD6 Boolean	643	Out-PZD6 Word	659		
4	Out-PZD7 Boolean	644	Out-PZD7 Word	660	Out-PZD7_8 Long	674
	Out-PZD8 Boolean	645	Out-PZD8 Word	661		
5	Out-PZD9 Boolean	646	Out-PZD9 Word	662	Out-PZD9_10 Long	675
	Out-PZD10 Boolean	647	Out-PZD10 Word	663		
6	Out-PZD11 Boolean	648	Out-PZD11 Word	664	Out-PZD11_12 Long	676
	Out-PZD12 Boolean	649	Out-PZD12 Word	665		
7	Out-PZD13 Boolean	650	Out-PZD13 Word	666	Out-PZD13_14 Long	677
	Out-PZD14 Boolean	651	Out-PZD14 Word	667		
8	Out-PZD15 Boolean	652	Out-PZD15 Word	668	Out-PZD15_16 Long	678
	Out-PZD16 Boolean	653	Out-PZD16 Word	669		
9	Out-PZD17 Boolean	654	Out-PZD17 Word	670	Out-PZD17_18 Long	679
	Out-PZD18 Boolean	655	Out-PZD18 Word	671		

- Note:**
- Every source can be connected to an inverter input parameter with the same data type. This method is the same as used with System-bus receive objects.
 - Boolean sources are representatives for Boolean objects
 - Word sources are representatives for current or torque objects
 - Long sources are representatives for frequency or position objects

13.3.3 Profibus input parameters (IN-PZD x)

The table below lists the available input parameters of the PZD In objects. The content of the sources depends on the application. For the different data types the equivalent input parameters must be connected to the inverter sources.

- Note:**
- The availability of In parameters depends on the number of configured PZD objects.
 - Every configured PZD object consists of either two Boolean, two word or one long input parameter.
 - One PZD In object can be used for one data type only (depending on the application requirements).
 - The first configured PZD object (mandatory) represents the PZD1/2 with fixed contents and functions.

no. of configured PZD objects	Parameter Boolean		Parameter Word		Parameter Long	
	name	p.-no.	name	p.-no.	name	p.-no.
2	In-PZD 3 Boolean	1300	In-PZD 3 Word	1302	In-PZD 3/4 Long	1304
	In-PZD 4 Boolean	1301	In-PZD 4 Word	1303		
3	In-PZD 5 Boolean	1305	In-PZD 5 Word	1307	In-PZD 5/6 Long	1309
	In-PZD 6 Boolean	1306	In-PZD 6 Word	1308		
4	In-PZD 7 Boolean	1310	In-PZD 7 Word	1312	In-PZD 7/8 Long	1314
	In-PZD 8 Boolean	1311	In-PZD 8 Word	1313		
5	In-PZD 9 Boolean	1315	In-PZD 9 Word	1317	In-PZD 9/10 Long	1319
	In-PZD 10 Boolean	1316	In-PZD 10 Word	1318		
6	In-PZD 11 Boolean	1320	In-PZD 11 Word	1322	In-PZD 11/12 Long	1324
	In-PZD 12 Boolean	1321	In-PZD 12 Word	1323		
7	In-PZD 13 Boolean	1325	In-PZD 13 Word	1327	In-PZD 13/14 Long	1329
	In-PZD 14 Boolean	1326	In-PZD 14 Word	1328		
8	In-PZD 15 Boolean	1330	In-PZD 15 Word	1332	In-PZD 15/16 Long	1334
	In-PZD 16 Boolean	1331	In-PZD 16 Word	1333		
9	In-PZD 17 Boolean	1335	In-PZD 17 Word	1337	In-PZD 17/18 Long	1339
	In-PZD 18 Boolean	1336	In-PZD 18 Word	1338		

The default setting for all input parameters (except parameters 1302/1303/1307/1308) is FALSE or zero.

The default setting for input parameters 1302/1303/1307/1308 is compatible to the former CM-PDP module with:

In-PZD 3 Word 1302 = 770 PDP absolute current

In-PZD 4 Word 1303 = 771 PDP active current

In-PZD 5 Word 1307 = 772 warning status

In-PZD 6 Word 1308 = 773 error status

- Note:**
- If one object is set to a specific source no., be sure that the corresponding objects for the same location are set to their default values. This method is the same as used with Systembus transmit objects.
 - Boolean inputs are representatives for boolean objects
 - Word inputs are representatives for current or torque objects
 - Long inputs are representatives for frequency or position objects

Note: The displayed "PDP active current" depends on the control system. In field-orientation, the torque-forming current is displayed, in applications with a v/f characteristic control, the active current, which is also a measure for the torque.
 The "PDP absolute current" (r.m.s. current) is always positive. Active current and torque-forming current have a sign prefixed.
 Positive currents = motor
 Negative currents = generator operation.

Current scaling:

Standardization			
Reference value	Binary	Decimal	Hexadecimal
+ 100 %	+ 2 ¹⁴	16384	0x4000

The possible range = ±200% = +32768 to -32768 = 0x8000 to 0x7FFF

For the internal scaling, the data set change-over capable parameter *Rated current* **371** is used as a reference.

Parameter		Setting		
No.	Description	Min.	Max.	Fact. Sett.
371	Rated current	0.01 · I _{FIN}	10 · I _{FIN}	I _{FIN}

13.4 Frequency conversion PDP word $\leftarrow \rightarrow$ inverter internal notation

If the inverter is equipped with the Profibus module CM-PDPV1 or an expansion module with Systembus, the function *convert PDP/intern* is available. This function converts frequency values in Profibus notation (see chapter 13.4.5 "PZD2, reference value/actual value") to frequency values in internal notation and vice versa.

Frequency Converter Profibus Notation/Internal Notation

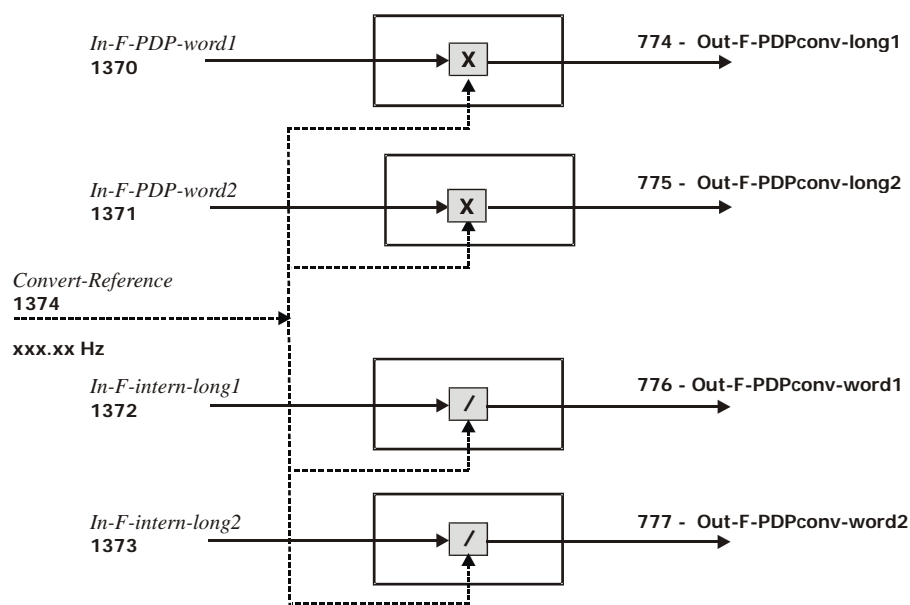

The scaling for In_F_PDP_word1/2 and Out_F_PDPconv_word1/2 is:

Standardization			
Reference value	Binary	Decimal	Hexadecimal
+ 100%	$+ 2^{14}$	16384	0x4000
- 100%	$- 2^{14}$	49152	0xC000

The possible range = $\pm 200\%$ = +32768 to -32768 = 0x7FFF to 0x8000

This function uses its own reference value *Convert-Reference* **1374** for data conversion. The benefit of this function is the usage of the word data type for frequency values, instead of long.

Note: The usage of this function and the usage of In-PZD/Out-PZD objects is shown in the sample project documented with:

- CM_PDPV1_conf.pdf Cluster with one inverter and CM-PDPV1 and three additional inverters coupled by Systembus
- CM_PDPV1_S7.pdf Functional description
- CC_0B2C.zip Complete STEP7 project including samples for In/Out-PZD usage and parameter access via PKW object and V1 channel
- S7-SoftwareOB1.pdf Listing of OB1 from STEP7 project

13.4.1 PZD1, control word/state word

In PZD1, the master gives its control commands (control word) to the frequency inverter in the output data set and receives the information on its state (status word) in the input data set.

The control of the frequency inverter can be carried out with three different operation modes. These are set via the data set change-over capable parameter *Local/Remote* **412**.

Parameter		Setting		
No.	Description	Min.	Max.	Fact. sett.
412	Local/Remote	0	44	44

For operation on the Profibus, only the settings 0, 1 and 2 are relevant. The remaining settings relate to the possibilities of control via the KP500 control unit.

Operation mode	Function
0 - Control via contacts	The Start and Stop command as well as the statement of the direction of rotation are set via digital signals.
1 - Control via state machine	The Start and Stop command as well as the statement of the direction of rotation are set via the DRIVECOM State machine of the communication interface.
2 - Control via remote contacts	The Start and Stop command as well as the statement of the direction of rotation are set via logic signals by the communication protocol.

Control word STW and state word ZSW have different contents depending on the operation mode. In each case, all or only some of the bits in the control word are relevant and also only certain feedbacks are possible via the status word. These are explained later in the descriptions of the three possible operation modes.

The control and state words have been created according to DRIVECOM. In this way, there is compatibility to PROFIDRIVE.

Note: Parameter *Local/Remote* **412** is data set change-over capable. Thus, switching over between various operation modes via the data set selection is possible. For example, it is possible to control a frequency inverter via the bus and to activate a local emergency operation if the bus master breaks down. This switch-over is also visible via the state word (Bit Remote).

Data set change-over can be carried out locally on the frequency inverter via contact inputs, or via the bus. For data set change-over via the bus, parameter *Data set selection* **414** is used.

Parameter		Setting		
No.	Description	Min.	Max.	Fact. sett.
414	Data set selection	0	4	0

With *Data set selection* **414** = 0, data set switch-over via contact inputs is active. If *Data set selection* **414** has been set to 1, 2, 3, or 4, then the corresponding data set has been activated. Data set switch-over via the contact inputs is then deactivated.

Via parameter *Active data set* **249**, the currently selected data set can be read out. *Active data set* **249** states the activated data set with the value 1, 2, 3 or 4. This is independent of whether the data set change-over was carried out via control inputs or via *Data set selection* **414**.

13.4.2 Control via contacts

In the operation mode control via contacts (*Local/Remote* 412 = 0), the frequency inverter is controlled via the contact inputs S2IND to S6IND. The meaning of these inputs can be taken from the operating instructions. The control word in PZD1 is not relevant for this operation mode.

State machine: The values displayed in the states are reflected in the status word (Bit 0 to Bit 6) in PZD1.

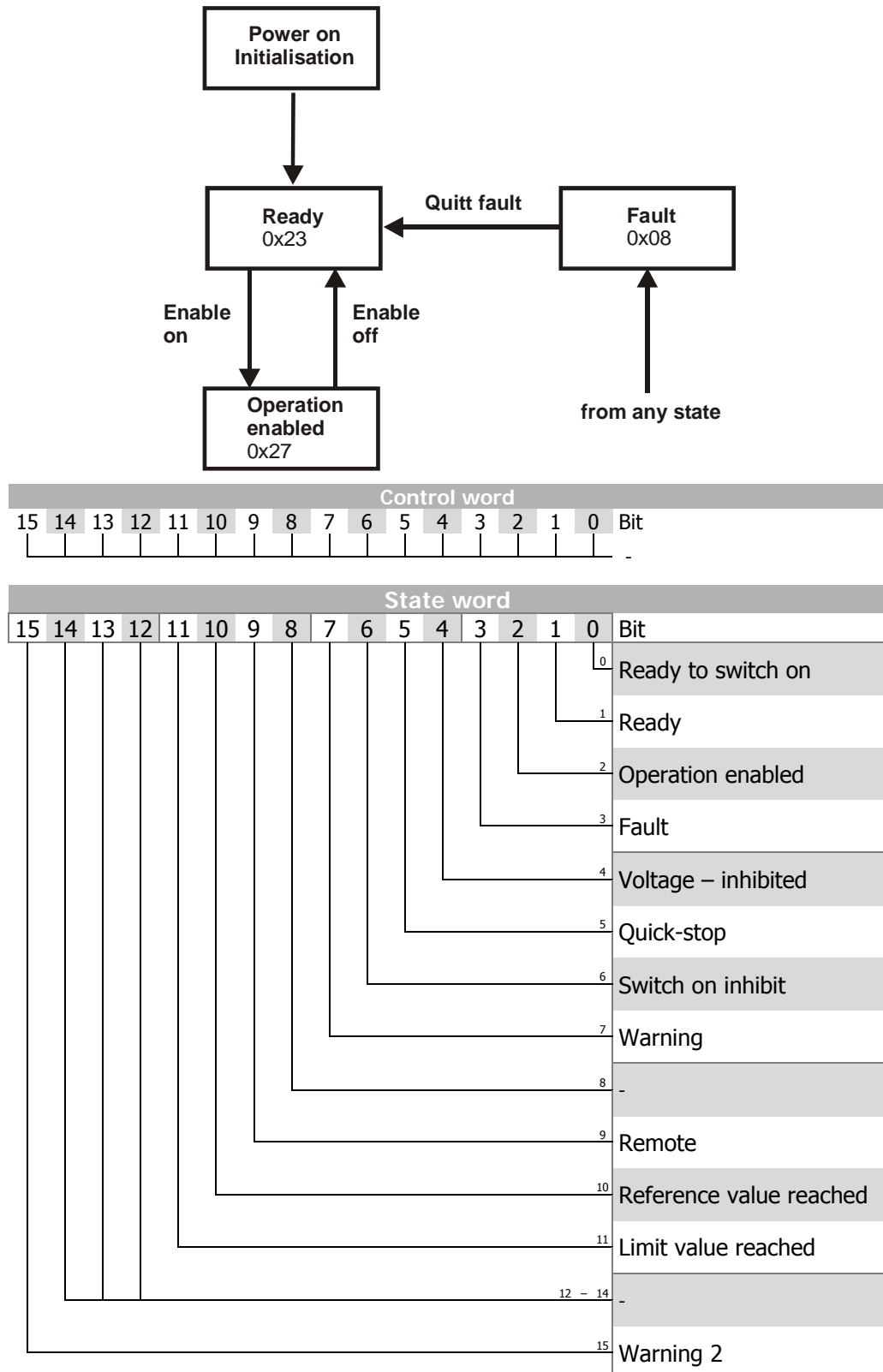

The status word reflects the operation state.

State word							
State	HEX (*)	Bit 6	Bit 5	Bit 3	Bit 2	Bit 1	Bit 0
Ready	0x23	0	1	0	0	1	1
Operation enabled	0x27	0	1	0	1	1	1
Fault	0x08	0	x	1	0	0	0

(*)without considering bits 7 to bit 15

Note: The occurrence of a fault leads to a switch-over to the "Fault" state. A fault can only be acknowledged 15 seconds after its occurrence, as a blocking time is active internally.

The **Warning bit "Bit No. 7"** can be set at any time. It indicates a device-internal warning message. The evaluation of the present warning is carried out by reading out the warning status with parameter *Warnings 270*.

The **Remote bit "Bit No. 9"** is always = 0.

The bit **Reference value reached "Bit No. 10"** is set whenever the specified reference value has been reached. In the special case of power failure regulation, the bit is also set if the power failure regulation has reached the frequency 0 Hz (see operating instructions). For "Reference value reached" there is a hysteresis (tolerance range), which can be set via parameter *max. Control deviation 549* (see operating instructions).

The bit **Limit value active "Bit No. 11"** indicates that an internal limit is active. This can, for example, be the present current limit, the torque limit or the over-voltage limit. All the functions lead to the reference value being quit or not reached.

The bit **Warning 2 "Bit No. 15"** indicates a warning which leads to a fault switch-off of the frequency inverter within a short period of time. This bit is set if there is a warning for motor temperature, heat sink/inside temperature, Ixt monitoring or mains phase failure.

13.4.3 Control via state machine

In the operation mode control via state machine (*Local/Remote 412 = 1*), the frequency inverter is controlled via the control word in PZD1. The possible states are shown in the diagram. The values on the transition identify these transitions between the states. The codes shown on the transitions, 0xnn, are the control word needed in each case (Bit 0 to Bit 7). The codes contained in the states, 0xnn, display the contents of the state word (Bit 0 to Bit 7).

After mains on (Reset), the frequency inverter is in the state "Switch-on inhibit" (0x40). With the transitions 4 and 5, there is a change between "Operation enabled" (0x27, power parts enabled, drive working) and "Ready" (0x23, power parts blocked).

Release (transition 4) is only possible if the hardware release is available via contact inputs **STOA AND STOB AND (S2IND OR S3IND)**. (S2IND = Start Clockwise, S3IND = Start Anticlockwise.) They can be firmly wired or firmly connected to On/Off via the configuration of the digital inputs. If the contact input STOA or STOB is switched off (or both), the inverter output stage is switched off. The drive coasts down to standstill. There is a transition to "Ready" (0x23, power parts blocked). For the function of the inputs STOA and STOB refer to the application manual "Safe Torque Off".

The behaviour of transition 5 can be set via parameter *State transition 5* **392**. Here, free stopping, shutdown via ramp (reversible) or DC braking (see Chapter 13.4.3.2 "Behaviour in transition 5") can be used.

State machine:

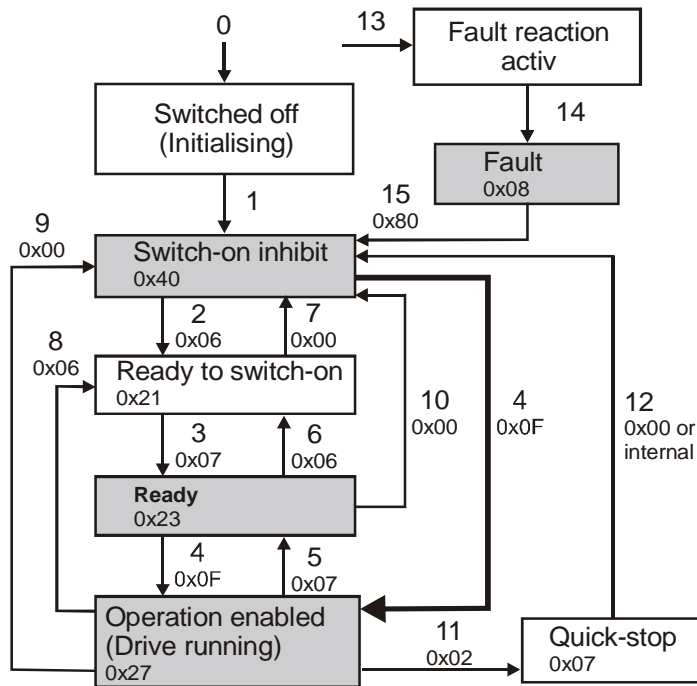

Control word																
15	14	13	12	11	10	9	8	7	6	5	4	3	2	1	0	Bit
															0	Switch on
															1	Voltage-inhibit
															2	Quick stop
															3	Operation-enabled
															4 - 6	-
															7	Reset-fault
															8 - 15	-

Control commands

The device control commands are triggered by the following bit combinations in the control word:

Control word							
Command	HEX	Bit 7	Bit 3	Bit 2	Bit 1	Bit 0	Transition
Shutdown	0x06	X	X	1	1	0	2, 6, 8
Switch-on	0x07	X	X	1	1	1	3
Voltage-inhibit	0x00	X	X	X	0	X	7, 9, 10
Quick-stop	0x02	X	X	0	1	X	11
Operation-inhibit	0x07	X	0	1	1	1	5
Operation enabled	0x0F	X	1	1	1	1	4
Reset faults	0x80	0 ⇒ 1	x	x	x	x	15

The shaded commands are the commands relevant for the simplified state machine.

To make operation of the device easier, a simplification has been implemented in the extension to the state machine defined under DRIVECOM. An additional transition from "Switch-on inhibit" to "Operation enabled" exists.

Note: The occurrence of a fault leads to a switch-over to the "Fault" state. The acknowledgement of the fault is carried out by a positive edge on Bit 7. A fault can only be acknowledged 15 seconds after its occurrence, as a blocking time is active internally.

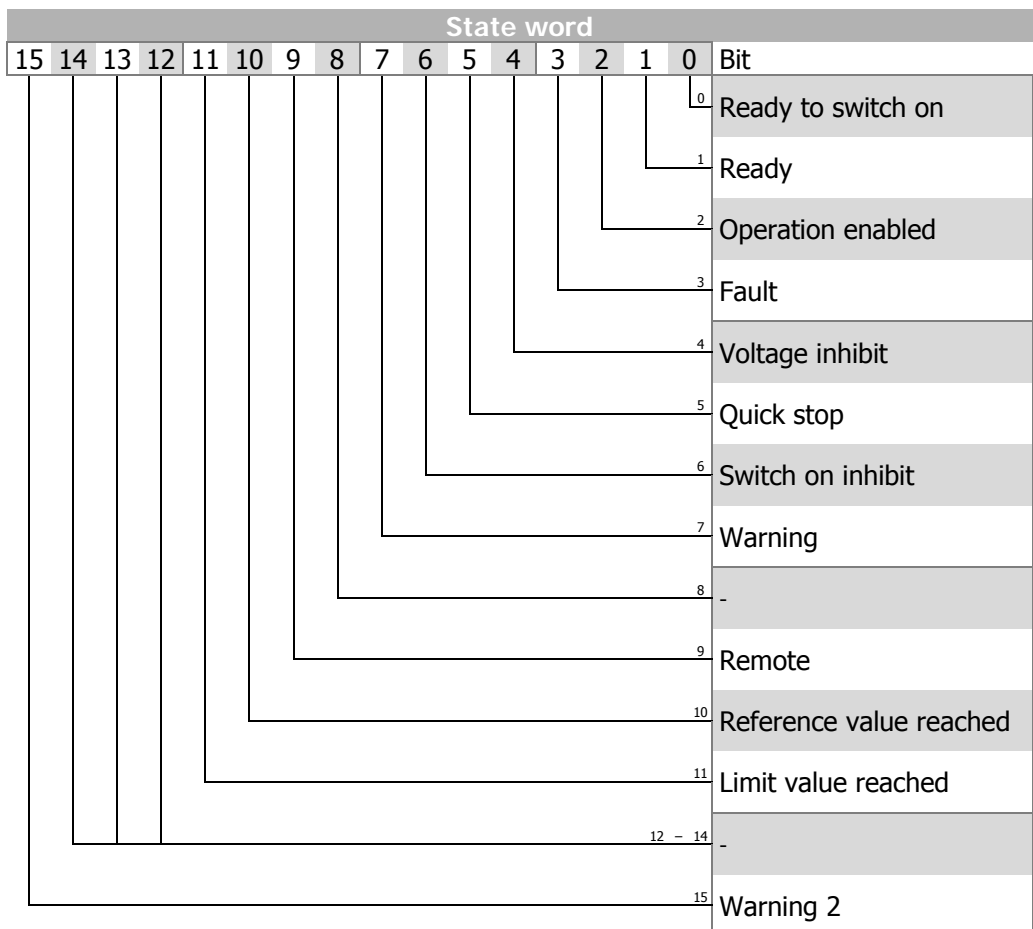

The state word reflects the operation state.

State word							
Meaning	HEX (*)	Bit 6	Bit 5	Bit 3	Bit 2	Bit 1	Bit 0
Switched-off	0x00	0	x	0	0	0	0
Switch-on inhibit	0x40	1	x	0	0	0	0
Ready to switch-on	0x21	0	1	0	0	0	1
Quick-stop	0x07	0	0	0	1	1	1
Ready	0x23	0	1	0	0	1	1
Operation enabled	0x27	0	1	0	1	1	1
Fault	0x08	0	x	1	0	0	0
Fault reaction active	0x0F	0	x	1	1	1	1

(*) without considering bits 7 to bit 15

The shaded commands are the commands relevant for the simplified state machine.

The **Warning bit "Bit No. 7"** can be set at any time. It indicates a device-internal warning message. The evaluation of the present warning is carried out by reading out the warning status with parameter *Warnings 270*.

The **Remote bit "Bit No. 9"** is set if the operation mode control via state machine (*Local/Remote 412 = 1*) has been set **and** the hardware release is available.

Logic linking of the digital control signals:

STOA AND STOB AND (S2IND OR S3IND)

The frequency inverter can only be controlled via the control word if the logic linking is true.

The bit **Reference value reached "Bit No. 10"** is set whenever the specified reference value has been reached. In the special case of power failure regulation, the bit is also set if the power failure regulation has reached the frequency 0 Hz (see operating instructions). For "Reference value reached" there is a hysteresis (tolerance range), which can be set via parameter *max. Control deviation 549* (see operating instructions).

The bit **Limit value active "Bit No. 11"** indicates that an internal limit is active. This can, for example, be the present current limit, the torque limit or the over-voltage limit. All the functions lead to the reference value being quit or not reached.

The bit **Warning 2 "Bit No. 15"** indicates a warning which leads to a fault switch-off of the frequency inverter within a short period of time. This bit is set if there is a warning for motor temperature, heat sink/inside temperature, Ixt monitoring or mains phase failure.

13.4.3.1 Behaviour in quick stop

In this, the parameters *Switch-off threshold 637* (percent of f_{max}) and *Holding time 638* (holding time after falling short of the switch-off threshold) are relevant. In a quick stop, the drive is shut down via the emergency stop ramps (*Emergency stop clockwise 424* or *Emergency stop anti-clockwise 425*).

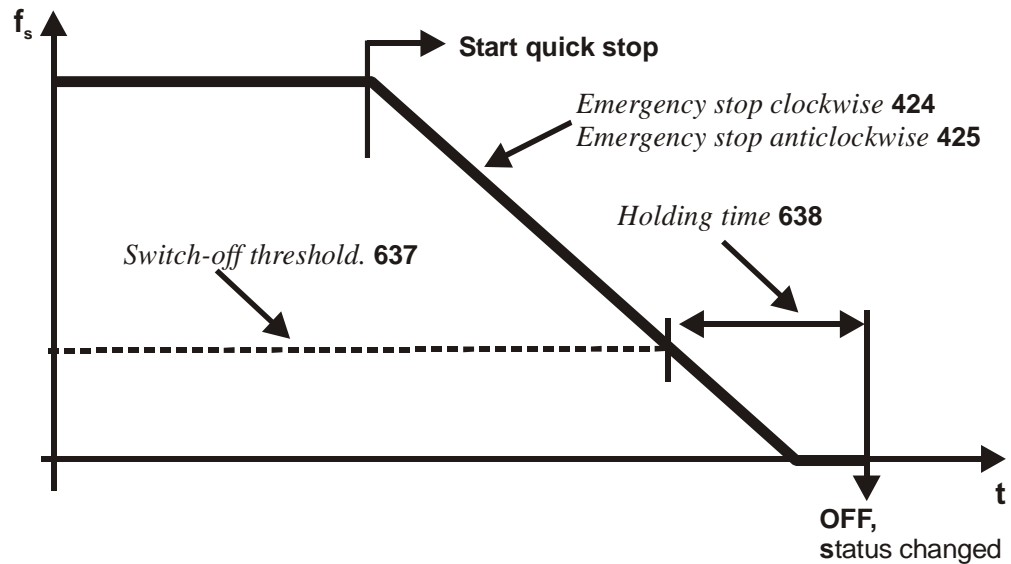

If frequency/speed zero has been reached during the holding time, the drive continues to be supplied with direct current until the switch-off time has expired. With this measure, there is an assurance that the drive is stationary in a change of state.

13.4.3.2 Behaviour in transition 5

The behaviour in transition 5 from "Operation enabled" to "Switched on" can be parameterised. The behaviour is set via parameter *State transition 5 392*.

Parameter		Setting		
No.	Description	Min.	Max.	Fact. sett.
392	State transition 5	0	2	2

Operation mode	Function
0 - Coast to stop	immediate transition from "Operation enabled" to "Ready", free stoppage of the drive
1 - DC brake	activation of DC brake, with the end of DC braking there is the change from "Operation enabled" to "Ready"
2 - Ramp	transmission with normal stop ramp, after reaching standstill, there is a change from "Operation enabled" to "Ready"

Note: Setting operation mode "1 - DC brake" is only possible in applications with v/f characteristic (e.g. configuration 110), as other applications do not know such an operation mode.
 If the frequency inverter is operated with a configuration which does not know the DC braking operation mode (e.g. configuration 210, field-orientation speed controlled), value "1" cannot be set. It is also not offered in the selection menus of the KP500 control unit or the VPlus program.

Note: The default value for parameter *State transition 5 392* is operation mode "2 - Ramp". For configurations with torque control, the default value is operation mode "0 - Coast to stop". If the configuration is changed, the value set for *State transition 5 392* is also altered, if necessary.

If transition 5 has been triggered with *State transition 5 392* = "1 - DC brake", a new control word is only accepted after the completion of the transition process. The change of state from "Operation enabled" to "Ready" is carried out after the expiry of the time *Braking time 632* parameterised for the DC brake.

If parameter *State transition 5 392* = "2 - Ramp" has been set, the control word can be set back to 0x0F during the stoppage of the drive. In this method, the drive runs back up to its set reference value and remains in the state "Operation enabled".

The change of state from "Operation enabled" to "Ready" is carried out after the set switch-off threshold has been reached **and** the set holding time has expired (equivalent to the behaviour in a quick stop). In this, the parameters *Switch-off threshold 637* (percent of fmax) and *Holding time 638* (holding time after switch-off threshold reached) are relevant.

13.4.4 Control via remote contacts

In the operation mode *Local/Remote* **412** = "2 - Control via remote contacts", the frequency inverter is controlled via the control word in PZD1, with the bits 0 to 9 corresponding to the contact inputs S1IND to S6IND, multifunctional input MFI1D and the inputs EM-S1IND to EM-S3IND of an expansion module.

In the use of the remote contacts, the frequency inverter behaves in the same way as in control via the hardware contact inputs. The meaning of these inputs can be taken from the operating instructions.

Note: Release is only possible if the hardware release is available via the digital inputs STOA and STOB.

State machine:

The values displayed in the states are reflected in the status word (Bit 0 to 6) in PZD1.

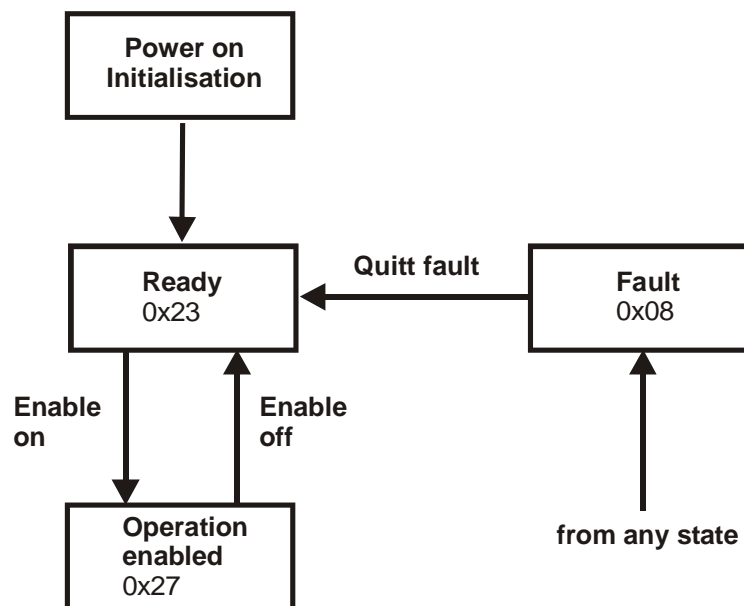

Note: The inputs set via the control word can be observed with the help of parameter *Digital Inputs* **250**. Digital input "Inverter Release" is only displayed as being set if the hardware release is available **and** the control word/Bit 0 has been set.

If the data set switch-over is used, please make sure that parameter *Local/Remote* **412** is set to operation mode "2 - Control via remote contacts" in all the data sets used.

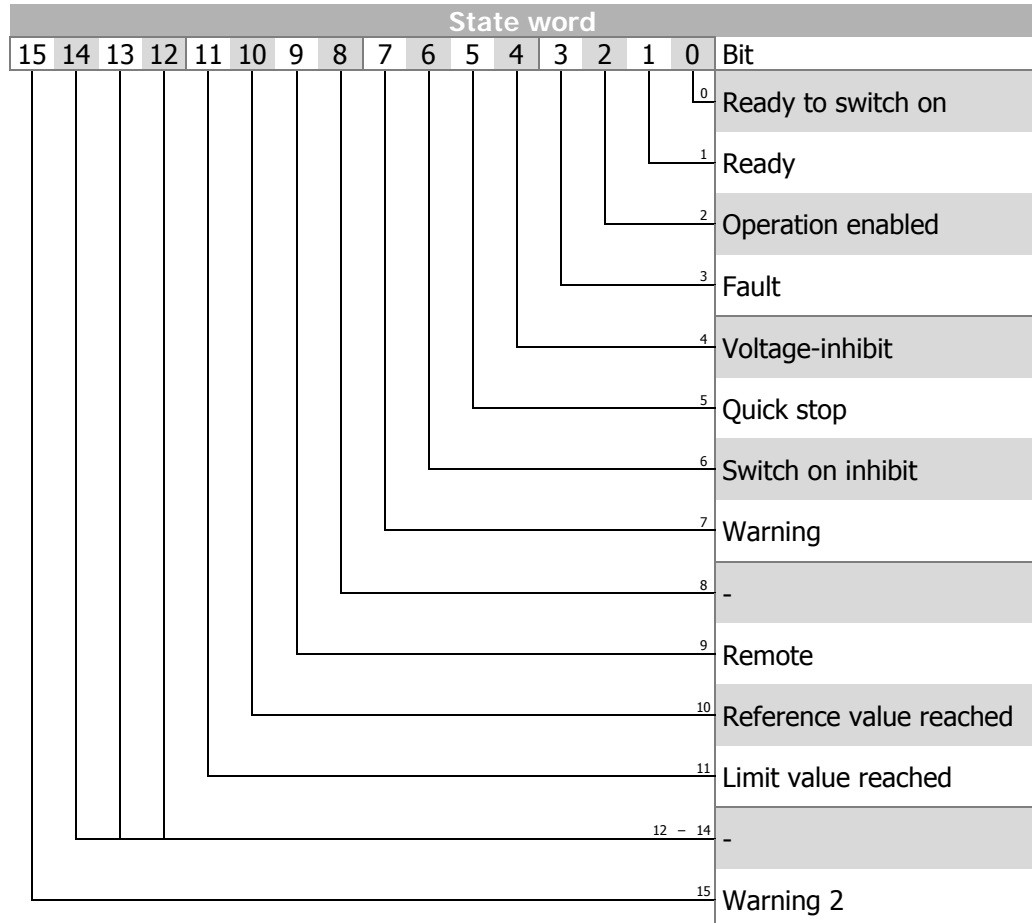
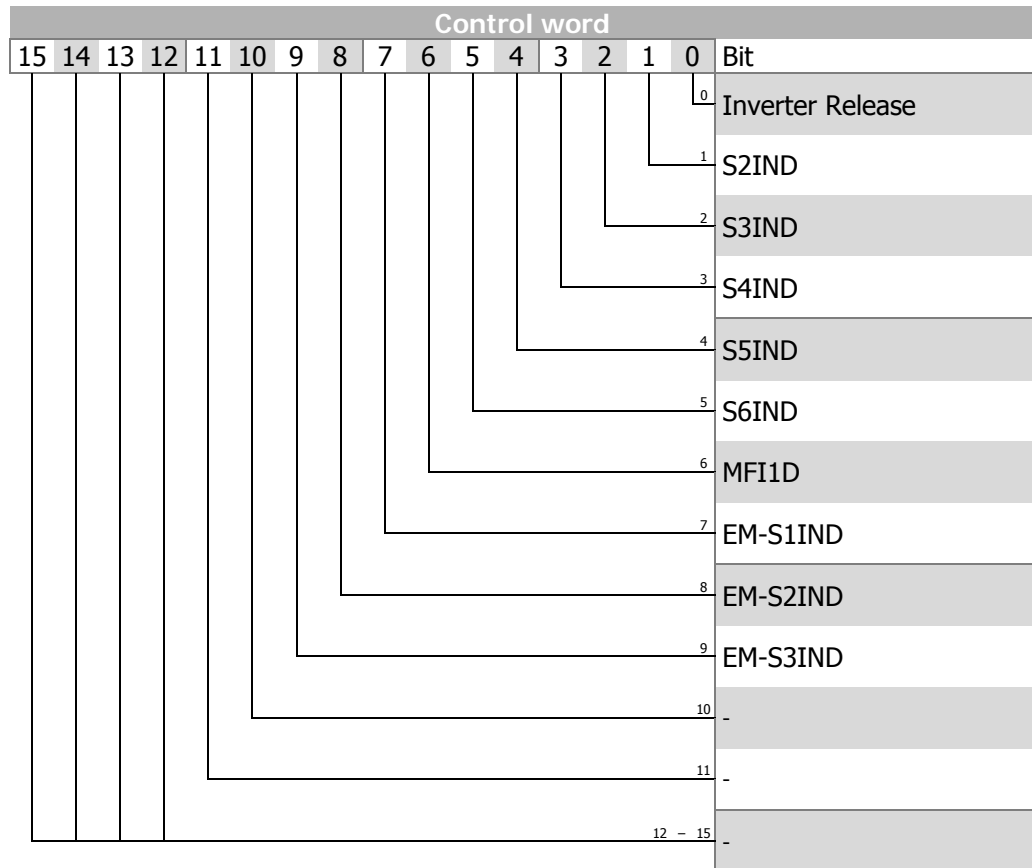

State word							
State	HEX (*)	Bit 6	Bit 5	Bit 3	Bit 2	Bit 1	Bit 0
Ready	0x23	0	1	0	0	1	1
Operation enabled	0x27	0	1	0	1	1	1
Fault	0x08	0	x	1	0	0	0

(*) without considering bits 7 to bit 15

Note: The occurrence of a fault leads to a switch-over to the "Fault" state. A fault can only be acknowledged 15 seconds after its occurrence, as a blocking time is active internally.

The **Warning bit "Bit No. 7"** can be set at any time. It indicates a device-internal warning message. The evaluation of the present warning is carried out by reading out the warning status with parameter *Warnings 270*.

The **Remote bit "Bit No. 9"** is set if the operation mode control via remote contacts (*Local/Remote 412 = 2*) has been set **and** the hardware release is available. Only then can the frequency inverter be controlled via the control word.

The bit **Reference value reached "Bit No. 10"** is set whenever the specified reference value has been reached. In the special case of power failure regulation, the bit is also set if the power failure regulation has reached the frequency 0 Hz (see operating instructions). For "Reference value reached" there is a hysteresis (tolerance range), which can be set via parameter *max. Control deviation 549* (see operating instructions).

The bit **Limit value active "Bit No. 11"** indicates that an internal limit is active. This can, for example, be the present current limit, the torque limit or the over-voltage limit. All the functions lead to the reference value being quit or not reached.

The bit **Warning 2 "Bit No. 15"** indicates a warning which leads to a fault switch-off of the frequency inverter within a short period of time. This bit is set if there is a warning for motor temperature, heat sink/inside temperature, Ixt monitoring or mains phase failure.

Note: With the use of remote contacts the signal sources* are taken over from the *Control Word 410*. Signals at the hardware contacts (terminals) are not evaluated by the standard operation modes (e.g. 71 for S2IND). For the evaluation of terminal signals special operation modes are available. They are denoted with the additional term "(Hardware)" and numbered from 526 to 546.
Exception: The controller release via the hardware contacts STOA (terminal X210A.3) and STOB (terminal X210B.2) must be set and Bit 0 "Inverter Release" of the *controlword* must be set.
It is not possible to release the controller only via software.

Signal sources are:
- S1IND ... S6IND,
- MFI1D,
- EM-S1IND ... EM-S3IND

13.4.5 PZD2, reference value/actual value

In the PZD2, the master gives its reference value to the frequency inverter in the output data set and gets information back on its actual value in the input data set.

The use of the reference/actual value channel depends on the configuration setting (control system). The actual value is generated from one of the sources according to the control system.

Note: The reference value and actual value are related to the parameter *Rated frequency 375 OR* the parameter *Profibus Reference 390*.

The distinction is made via the setting of parameter *Profibus Reference 390*. If *Profibus Reference 390 = 0*, *Rated frequency 375* is the reference variable. If *Profibus Reference 390 ≠ 0*, *Profibus Reference 390* is used as the reference variable. Both parameters are capable of data set change-over.

Parameter		Setting		
No.	Description	Min.	Max.	Fact. Sett.
375	Rated frequency	10.00 Hz	1000.00 Hz	50.00 Hz
390	Profibus Reference	0.00 Hz	999.99 Hz	0.00 Hz

Reference and actual values are transmitted in a standardised form. The standardisation is carried out by the variables being related to the reference value (*Rated frequency 375 OR Profibus reference 390*).

Standardization			
Reference value	Binary	Decimal	Hexadecimal
+ 100 %	+ 2 ¹⁴	16384	0x4000
- 100 %	- 2 ¹⁴	49152	0xC000

The possible range = ±200 % = +32768 to -32768 = 0x7FFF to 0x8000

Example: The setting of parameter *Profibus Reference 390* is the reference value 60.00 Hz. The required reference frequency is 30.00 Hz. This means 50% of the reference value, thus the set point 8192 (0x2000) has to be transmitted.

With the reference value *Profibus Reference 390* a machine can also be operated in the field weakening area above its reference frequency.

Example: The parameter *Rated frequency 375* is set to a frequency of 50.00 Hz. With the setting of parameter *Profibus Reference 390* to 100.00 Hz the value range of ± 200 Hz is possible.

The reference value for the frequency inverter from PZD2 is included via the line set point value. This reference value is combined with the internal set point value from the reference frequency channel in the input of the ramp function. For the reference frequency channel, see the operating instructions.

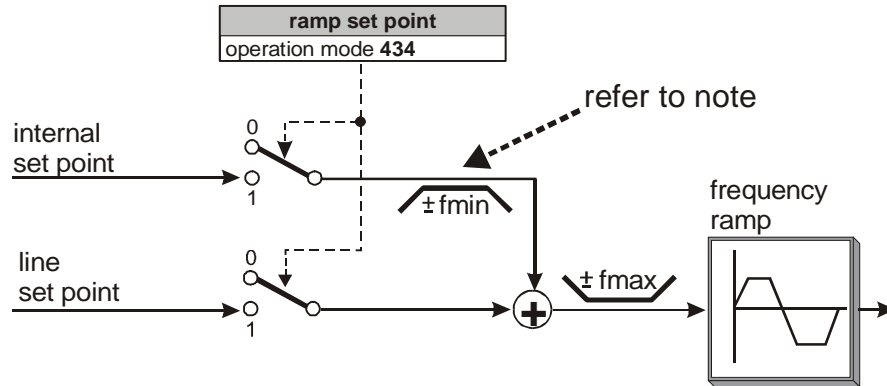

The internal set point value from the reference frequency channel and the line set point value can be fed to the ramp individually or as an added variable. The setting is carried out via the data set change-over capable parameter *Ramp set point 434*.

Parameter		Setting		
No.	Description	Min.	Max.	Fact. sett.
434	Ramp set point	1	3	3

Operation mode		Function
1 - Internal set point		Reference value from the source percent or frequency reference value channel
2 - Line set point		Reference value from the communication interface
3 - Internal + line set point		Reference sum of internal set point and line set point

The reference value can be controlled on the frequency inverter via the KP500 control unit or the VPlus program.

Note: If *Ramp set point 434* = 2 (only line set point value), then this reference line value is limited to f_{min} . Please remember that the sign in front of f_{min} at reference value = 0 is derived from the sign in front of the last line set point value $\neq 0$.
After Power on, the reference line value is limited to $+f_{min}$!

For *Ramp set point 434* = 3, the sign in front of the overall reference value results from the sum of internal + line set point value.

Actual values		
Parameter	Content	Format
<i>Internal reference frequency 228</i>	internal set point value from reference frequency channel	xxx.xx Hz
<i>Reference bus frequency 282</i>	line set point value from Profibus	xxx.xx Hz
<i>Reference ramp frequency 283</i>	sum of internal set point value + line set point value	xxx.xx Hz

13.5 Actual value display of Profibus data

For analysis purposes, *DP-Master OUT 281* and *DP-Master IN 284* are displayed in the data transmitted via the Profibus under the actual value parameters.

The parameters are situated in the "**Actual values\Actual values frequency inverter**" menu of the VPlus program and can only be viewed with the latter.

In these parameters, the data transmitted via the Profibus are displayed in a processed and comprehensible form. The contents of the process data channel with control word, reference value etc. are permanently updated. As the communication channel has the contents zero in idling and transmission is very fast, the contents of the communication channel are stored on the device side and displayed in the actual value parameters with every transmission.

The displayed content of the communication channel does not correspond to the current state, but the last transmission.

Note: The use of the VPlus program with simultaneous use of the Profibus-DP communication module CM-PDPV1 is only possible with the KP232 serial adapter on the slot of the KP500 control unit.
Only the usage of the PKW object is displayed for parameter access.
When using the V1-Channel for parameter access there is no information displayed.

The following diagrams show the display for a configuration setting with PPO2. The PPO2 includes the communication PKW channel for parameter access and 6 PZD objects with default settings for In-PZD objects.

Actual value

Parameter DP-Master OUT 281

= C: a nnnn I: iiiii 00 V: wwwwww cccc rrrr xxxx xxxx xxxx xxxx

Meaning

C: a	a	= request identification	hexadecimal
C: nnnn	nnnn	= parameter number	decimal
I: iiiii	iiii	= index	hexadecimal
V: ww..w	ww..w	= parameter value	decimal (with sign in front)
cccc	PZD1	= control word	hexadecimal
rrrr	PZD2	= reference value	hexadecimal, relative to 0x4000 = 100% of the reference value
xxxx	PZD3	user defined	hexadecimal
xxxx	PZD4	user defined	hexadecimal
xxxx	PZD5	user defined	hexadecimal
xxxx	PZD6	user defined	hexadecimal

Actual value

Parameter DP-Master IN 284

= C: a nnnn I: iiiii 00 V: wwwwww cccc ssss xxxx xxxx xxxx xxxx

Meaning

C: a	a	= reply identification	hexadecimal
C: nnnn	nnnn	= parameter number	decimal
I: iiiii	iiii	= index	hexadecimal
V: ww..w	ww..w	= parameter value	decimal (with sign in front)
cccc	PZD1	= state word	hexadecimal
ssss	PZD2	= actual value	hexadecimal, relative to 0x4000 = 100% of the reference value
xxxx	PZD3	= abs. current	hexadecimal, relative to 0x4000 = 100% of the rated motor current
xxxx	PZD4	= active current	hexadecimal, relative to 0x4000 = 100% of the rated motor current
xxxx	PZD5	= Warning	hexadecimal (bit-coded)
xxxx	PZD6	= Fault	hexadecimal

Example:
Actual value
Parameter DP-Master OUT 281
= C: 6 480 I: 0300 V: -005500 000F 2000 0000 0000 0000 0000
Meaning

C: 6	Request identification = 6 (Read parameter value Array)
C: 480	Parameter number = 480 (Fixed frequency 1)
I: 0300	Data set = 3
V: -005500	Parameter value = -5500 = -55.00 Hz (0xFFFEA84 hexadecimal)
000F	Release command (transition 4)
2000	Set point = 0x2000 = 50% of the reference value
0000	not used
0000	not used
0000	not used
0000	not used

Actual value
Parameter DP-Master IN 284
= C: 5 480 I: 03 00 V: -005500 06A7 2000 1147 0CCC 0800 0000
Meaning

C: 5	Reply identification = 5 (Transmit parameter value long Array)
C: 480	Parameter number = 480 (Fixed frequency 1)
I: 03 00	Data set = 3
V: -005500	Parameter value = -5500 = -55.00 Hz (0xFFFEA84 hexadecimal)
06A7	State = 0x27 "Operation enabled" (Bit 0 ... 6), Warning 2 present (Bit 15 = 1 threat of fault switch-off), reference value reached (Bit 10 = 1), remote operation (Bit 9 = 1), Warning present (Bit 7 = 1)
2000	Actual value = 0x2000 = 50% of the reference value
1147	Abs. current = 0x1147 = 27% of the rated motor current
0CCC	Active current = 0x0CCC = 20% of the rated motor current
0800	Warning, Warning motor temperature available
0000	Fault, no fault available

14 Parameter list

The parameter list is structured according to the menu branches of the operating unit. For better clarity, the parameters have been marked with pictograms:





-  The parameter is available in the four data sets
- The parameter value is set by the SET-UP routine
- This parameter cannot be written when the frequency inverter is in operation

14.1 Actual values

Actual values of the frequency inverter				
No.	Description	Unit	Display range	Chapter
228	Internal reference frequency	Hz	-1000.00 to 1000.00	13.4.5
249	Active data set	-	1 to 4	13.4.1
250	Digital inputs	-	0 to 255	13.4.4
270	Warnings	-	0 to 0xFFFF	15.1
281	DP-Master OUT	-	String	13.5
282	Reference bus frequency	Hz	-1000.00 to 1000.00	13.4.5
283	Reference ramp frequency	Hz	-1000.00 to 1000.00	13.4.5
284	DP-Master IN	-	String	13.5
365	Status Control	-	0 to 7	8
366	Status Fieldbus Module	-	1 to 15	8

Note: The parameters *DP Master OUT 281* and *DP Master IN 284* can only be displayed via the VPlus program. Operation of the VPlus program, when using the Profibus-DPV1 communication module CM-PDP, is only possible via the optional KP232 serial adapter on the slot of the KP500 control unit. The parameter *Warnings 270* is only accessible via the communication channel of objects PPO1 and PPO2. It cannot be accessed via the VPlus program or the KP500 control unit.

14.2 Parameters

Profibus				
No.	Description	Unit	Setting range	Chapter
329	DP-V1 Mode	-	1 to 2	13.2
Rated motor parameters				
 375	Rated frequency	Hz	10.00 to 1000.00	13.4.5
Profibus				
390	Profibus Reference	Hz	0.00 to 999.99	13.4.5
391	Profibus Node-ID	-	-1 to 126	6
Bus control				
392	State-transition 5	-	0 to 2	13.4.3.2
Profibus				
393	Profibus Error Reaction	-	0 to 3	9
Bus control				
412	Local/Remote	-	0 to 44	13.4.1
Data set change-over				
414	Data set selection	-	0 to 4	13.4.1
Frequency ramps				
 424	Emergency stop clockwise	Hz/s	0.01 to 9999.99	13.4.3.1
 425	Emergency stop anticlockwise	Hz/s	0.01 to 9999.99	13.4.3.1
Frequency ramps				
434	Ramp set point	-	1 to 3	13.4.5
Digital outputs				
549	Max. Control deviation	%	0.01 to 20.00	13.4.2
Stopping behaviour				
 637	Switch-off threshold	%	0.0 to 100.0	13.4.3.1
 638	Holding time	s	0.0 to 200.0	13.4.3.1
Profibus				
1300	In-PZD 3 Boolean	-		13.3.3
.	.			
.	all In-PZD parameters			
.	.			
1339	In-PZD 17/18 Long	-		

Note: The parameter *Data set selection 414* is only accessible via the communication channel of objects PPO1 and PPO2. It cannot be accessed via the Vplus program or the KP500 control unit.

15 Annex

15.1 Warning messages

The various control functions and methods and the hardware of the frequency inverter contain functions that continuously monitor the application. In addition to the messages documented in the manual, the following warning messages are activated by the Profibus-DP communication module CM-PDPV1.

The warning messages are given via parameter *Warnings 270*, bit-coded according to the following scheme:

Warning messages		
Bit no.	Warning code	Meaning
0	0x0001	Warning Ixt
1	0x0002	Warning Short Term - Ixt
2	0x0004	Warning Long Term - Ixt
3	0x0008	Warning Heat sink Temperature Tc
4	0x0010	Warning Inside Temperature Ti
5	0x0020	Warning Limit
6	0x0040	Warning Init
7	0x0080	Warning Motor Temperature
8	0x0100	Warning Mains Failure
9	0x0200	Warning Motor Protective Switch
10	0x0400	Warning Fmax
11	0x0800	Warning Analog Input MFI1A
12	0x1000	Warning Analog Input A2
13	0x2000	Warning System bus
14	0x4000	Warning Udc
15	0x8000	Warning V-Belt

Note: The meaning of the individual warnings are described in detail in the operating instructions.

15.2 Fault messages

The fault code that is stored after a fault occurs is made up of the fault group FXX (high Byte, hexadecimal) followed by the code number XX (low Byte, hexadecimal).

Communication fault		
Code		Meaning
F20	62	Profibus OFF (communication connection to DP Master lost) *
F26	02	Communication watchdog CM-PDPV1 / inverter controller

* This message only appears whenever *Profibus Error Reaction 393* = 1 – Error.

In addition to the fault messages stated, there are further fault messages used for internal purposes only and which are not listed here. If you receive any fault messages which are not listed, please contact us by phone.

15.3 GSD File – BV__0B2C.GSD

```

=====
; Profibus Device Database of HMS Industrial Networks.
;
; Model          Anybus-CC PROFIBUS DP-V1
;                CM-PDPV1 at Bonfiglioli Vectron GmbH
; Description:   Anybus-CC PROFIBUS DP-V1 slave
; Language:     English
; Author:       HMS Industrial Networks / Bonfiglioli Vectron GmbH
; WWW:         www.anybus.com / www.vectron.net
;
; Revision log:
; 09.08.2007 Bonfiglioli Vectron GmbH
; Model_name changed to ACTIVE-DPV1
; Ident_Number changed to 0x0B2C (PNO)
; Slave family changed to 1 "Drive"
; I/O related keywords changed to Bonfiglioli settings
; Unit_Diag_Area=32-39 changed to Bonfiglioli settings
; C1/2_Max_Data_Len ,C1/2_Response_Timeout changed to Bonfiglioli settings
; Definition of modules changed to Bomfiglioli settings
;
=====
#Profibus_DP

GSD_Revision      = 5

; Device identification
Vendor_Name       = "HMS Industrial Networks"
Model_Name        = "ACTIVE-DPV1"
Revision          = "2.05"
Ident_Number      = 0x0B2C
Protocol_Ident    = 0          ; DP protocol
Station_Type      = 0          ; Slave device
FMS_supp          = 0          ; FMS not supported
Slave_Family      = 1          ; Drive
Hardware_Release  = "Version 2.03"
Software_Release  = "Version 2.03"

; Supported hardware features
Redundancy        = 0          ; not supported
Repeater_Ctrl_Sig = 2          ; TTL
24V_Pins          = 0          ; not connected
Implementation_Type = "NP30"

; Supported DP features
Freeze_Mode_supp = 1          ; supported
Sync_Mode_supp   = 1          ; supported
Auto_Baud_supp   = 1          ; supported
Set_Slave_Add_supp = 1        ; supported
Fail_Safe        = 1          ; supported

; Supported baudrates
9.6_supp         = 1
19.2_supp        = 1
45.45_supp       = 1
93.75_supp       = 1
187.5_supp       = 1
500_supp         = 1
1.5M_supp        = 1
3M_supp          = 1
6M_supp          = 1
12M_supp         = 1

; Maximum responder time for supported baudrates
MaxTsdr_9.6      = 15
MaxTsdr_19.2     = 15
MaxTsdr_45.45    = 15
MaxTsdr_93.75    = 15
MaxTsdr_187.5    = 15
MaxTsdr_500      = 15
MaxTsdr_1.5M     = 25
MaxTsdr_3M       = 50
MaxTsdr_6M       = 100
MaxTsdr_12M      = 200

```

```

; Maximum polling frequency
Min_Slave_Intervall = 1 ; 100 us

; I/O related keywords
Modular_Station = 1 ; modular
Max_Module = 9
Max_Input_Len = 36
Max_Output_Len = 36
Max_Data_Len = 72
Modul_Offset = 1

; Parameterization related keywords
Max_User_Prm_Data_Len = 3
Ext_User_Prm_Data_Const(0) = 0xC0,0x00,0x00

; Diagnostic related keywords
Max_Diag_Data_Le = 80

;Status diagnostic messages
Unit_Diag_Area =16-17
Value(0) = "Status not changed"
Value(1) = "Status appears"
Value(2) = "Status disappears"
Unit_Diag_Area_End

Unit_Diag_Area=24-31
Value(0) = "Minor, recoverable"
Value(16) = "Minor, unrecoverable"
Value(32) = "Major, recoverable"
Unit_Diag_Area_End

Unit_Diag_Area=32-39
Value(1) = "Ixt"
Value(2) = "Heat Sink Temperature"
Value(3) = "Device Temperature"
Value(4) = "Motor Temperature"
Value(5) = "Overcurrent"
Value(6) = "Power Unit Detection"
Value(7) = "DC-Link Voltage"
Value(8) = "Internal Power Supply"
Value(9) = "Preload Contactor"
Value(10) = "EEPROM Fault"
Value(11) = "CPU Fault"
Value(12) = "Internal Configuration Fault"
Value(16) = "Brake Chopper"
Value(17) = "Frequency Limit"
Value(18) = "Safety Relais"
Value(19) = "Motor Connection"
Value(20) = "Peripheral Fault"
Value(21) = "Table Travel"
Value(32) = "Communication Fault"
Value(33) = "Systembus Emergency"
Value(34) = "Systembus Fault"
Value(38) = "Fieldbus Modul"
Value(48) = "Operator Fault"
Value(255) = "Device Specific"
Unit_Diag_Area_End

; DPV1 related keywords
DPV1_Slave = 1
Check_Cfg_Mode = 0

C1_Read_Write_supp = 1
C1_Max_Data_Len = 120
C1_Response_Timeout = 200 ;2 sec

C2_Read_Write_supp = 1
C2_Max_Data_Len = 120
C2_Response_Timeout = 200 ;2 sec
C2_Max_Count_Channels = 1
Max_Initiate_PDU_Length = 52

Ident_Maintenance_supp = 1

```

```
; Definition of modules
Module = "PPO1: 4 Words PKW, 2 Words PZD" 0xF3 , 0x71
1
EndModule
;
Module = "PPO2: 4 Words PKW, 6 Words PZD" 0xF3 , 0x75
2
EndModule
;
Module = "PPO3: 2 Words PZD IN/OUT" 0x71
3
EndModule
;
Module = "PPO4: 6 Words PZD IN/OUT" 0x75
4
EndModule
;
Module = "PKW 4 Words IN/OUT" 0xF3
5
EndModule
;
Module = "PZD 2 Words IN/OUT" 0x71
6
EndModule
;
```



ACTIVE Cube

The image shows a small, dark, rectangular industrial device labeled 'ACTIVE Cube'. It is positioned on a grid surface with a bar chart in the background. The entire scene is overlaid with a semi-transparent, glowing cube and surrounded by binary code (0s and 1s) scattered across the page.

www.bonfiglioli.com

 **BONFIGLIOLI**