



# B Minas A4/A4N Series Servo Drives

Main Features – Increased Performance and Accuracy



- Fast response frequency: 1000Hz
- Completely adjustment-free, real-time auto-gain tuning
- High performance vibration control
- Command input up to 2Mpps
- Smaller motors and drivers versus the former series
- Position, velocity and torque control support – a wide range of applications in one driver
- Many more additional functions:
  - Hit & Stop homing, i.e. homing without a switch
  - Press/Tension control
  - 8 internal JOG speeds
  - Others

	Low inertia types	Middle / High inertia types*
Motor output power rating	50W to 5kW	400W to 7.5kW
Nominal/maximum speed	3000/5000rpm	
Nominal torque	0.16 to 15.8Nm	1.9 to 57.2Nm
Peak torque	0.48 to 47.6Nm	5.3 to 137Nm
Moment of inertia	0.025 to 19.7 x 10 <sup>-4</sup> kg x m <sup>2</sup>	2.45 to 288 x 10 <sup>-4</sup> kg x m <sup>2</sup>
Encoder	Incremental	2500 pulses/rev
	Absolute/Incremental*	17-bit resolution

\* On demand Only



# B Minas A4/A4N Series Servo Drives

## Details of Features

### ■ ADJUSTMENT-FREE OPERATION

#### High-functionality real-time auto-gain tuning

- Automatically tunes in real-time to variations in load inertia. Real-time auto-gain tuning for machines with low or high stiffness.
- Supports vertical axis applications where the load torque varies depending on rotational direction.
- An over-travel detection function prevents the machine from over-travelling during real-time auto-gain tuning.
- Enables you to set and check while monitoring real-time automatic gain tuning conditions on the front panel.

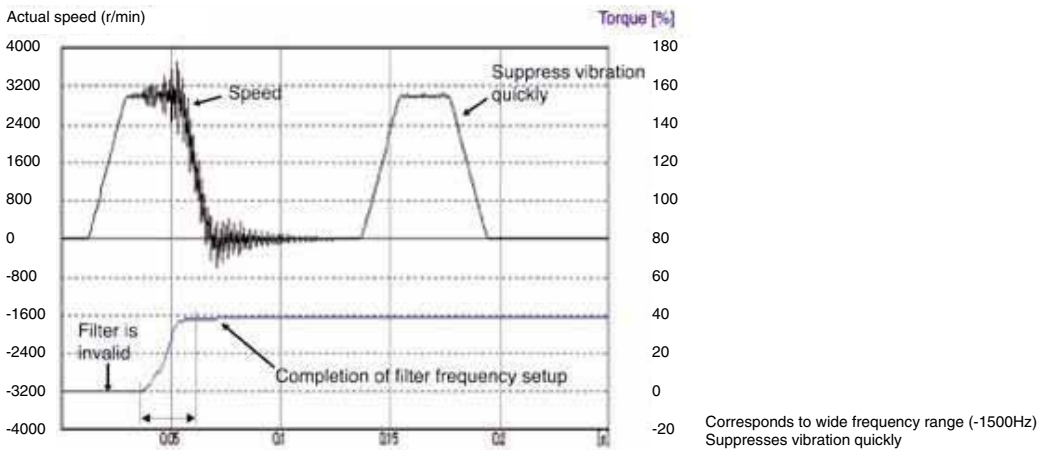

### ■ HIGH-SPEED AND FAST RESPONSE

#### Velocity response (bandwidth) of 1kHz

- The instantaneous Velocity Observer detects the motor speed more quickly and with a higher resolution than the previous models.

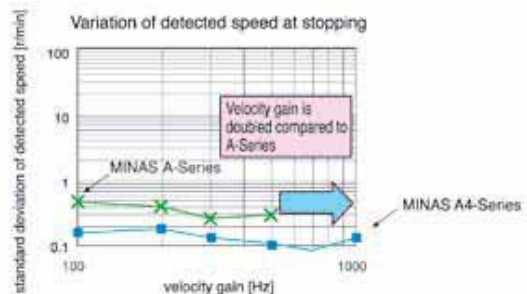
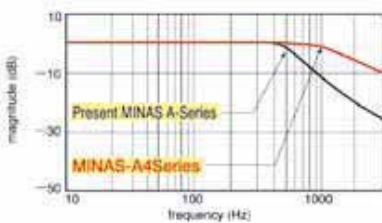

#### High-functionality real-time auto-gain tuning

- Enables low stiffness machines (e.g. belt-driven machines) and high stiffness machines (e.g. short stroke ball-screw driven machines) to be used in high-speed positioning applications.



# B Minas A4/A4N Series Servo Drives

## Details of Features

### REDUCTION VIBRATION

#### Adaptive Filter

- Enables the notch filter frequency to automatically follow the machine resonance frequency.
- Suppresses judder noise of the machine caused by a change in the resonance frequency (e.g. resulting from aging effects or changeovers).

### 2-CHANNEL NOTCH FILTERS

#### Adaptive Filter

- The driver is equipped with 2-channel notch filters which operate independently from the adaptive filter.
- Both frequency and width for each of the 2 filters can be set. Frequency can be defined in units of 1Hz.
- Suppress judder noise of machines with multiple resonance points.

Effect of notch filter

Without notch filter

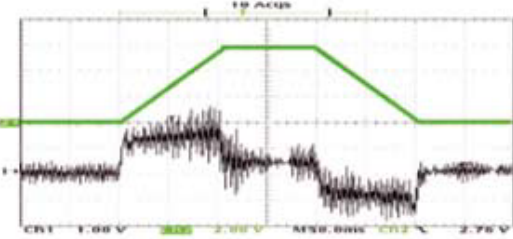

50ms/div

With notch filter

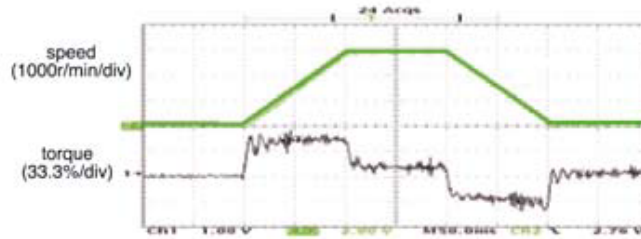

50ms/div

### DAMPING CONTROL

- The driver is equipped with a 2-channel damping filter. You can suppress vibration occurring at both starting and stopping in low stiffness machines by manually setting up vibration frequencies in 0.1Hz units.
- You can switch between the channels with the direction command or with an external input.
- Easy setup with input of only frequency and filter values. Incorrect setup values do not result in unstable operation.

Motor movement

Without damping control

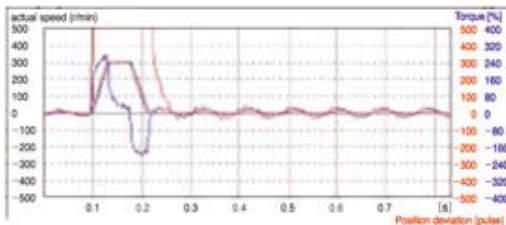

Machine movement

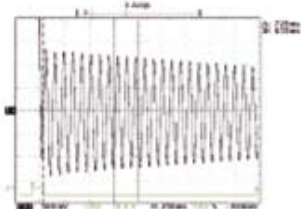

With damping control

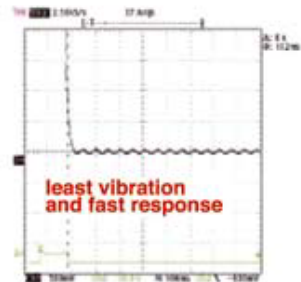
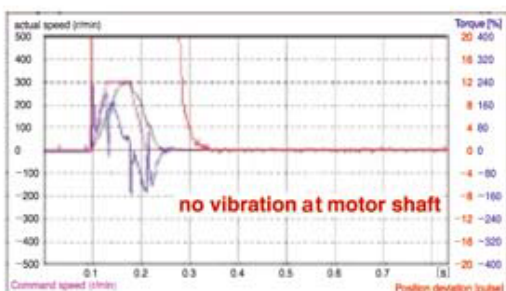



# B Minas A4/A4N Series Servo Drives

## Additional Features

### ■ SETUP SUPPORT WITH HELPFUL MONITORING FUNCTIONS

- Faster communication speed of RS232C/RS485 (max. 57600bps) establishes easy and comfortable operating conditions for setup support software PANATERM®.
- PANATERM® displays useful status information, e.g. to help you analyse motor problems.
- You can enable the panel operation lock via the front panel to inhibit operation, e.g. to prevent parameters from being changed unintentionally.

### ■ COMMAND CONTROL MODES

- Offers you "Position", "Velocity (including internal 8-speed)" and "Torque" command control modes.
- You can select any one of the above command control modes, or select two command control modes by defining the parameters.
- You can combine command control modes in a hybrid mode and switch between them.

### ■ MONITORING FUNCTION WITH FRONT PANEL

- LED display and analogue monitor terminals are installed in the front panel.
- Displays "Motor speed", "Motor torque", "Position deviation", "Motor load factor" and "Regeneration load factor".
- You can monitor "Motor speed", "Motor torque" and "Position deviation" with analogue monitor terminals.

### ■ TRIAL RUN (JOG)

- Features the function for trial run (JOG) through the front panel or console (option) without connecting to a host controller.
- Shortens machine setup time.

### ■ FULL-CLOSED CONTROL (HIGH PRECISION POSITIONING)

- Features the full-closed control of position and velocity, using the signals from the linear scale installed on the load side and the high resolution encoder.
- Best suited for high precision machines.

### ■ INRUSH CURRENT SUPPRESSING FUNCTION

- The driver is equipped with an inrush suppressing resistor which prevents circuit breaker shutdown of the power supply caused by inrush current at power-on.
- Prevents unintentional shutdown of the power supply circuit breaker in multi-axis applications and does not add load to the power line.

### ■ REGENERATION DISCHARGING FUNCTION

- Discharges regenerative energy, which is returned from the motor to the driver with a resistor, e.g. stopping a load with a large moment of inertia or with the up-down operation.
- Frame A and Frame B drivers do not have a built-in regeneration discharge resistor. We recommend connecting an optional regenerative resistor.
- Frame C – Frame F drivers have a built-in regeneration discharge resistor. However, connecting an optional regenerative resistor will add even more regenerative capability.

### ■ BUILT-IN DYNAMIC BRAKE

- The driver is equipped with a dynamic brake for emergency stop.
- The dynamic brake can be used in the following instances:
  - Main power OFF
  - Servo OFF
  - A protective function
  - Over-travel inhibit is activated

### ■ POSITIONING PULSE

- Up to 2Mpps of pulse input at positioning control possible.

### ■ TORQUE LIMIT VALUE SWITCHING

- You can set up 2 torque limits and use them for tension control or press & hold control.



# B Minas A4/A4N Series Servo Drives

## Overview Minas A4 /A4N Drivers



Minas A4 standard drivers	Minas A4N networking drivers	Rated power	Supply voltage	Frame	Maximum instantaneous output current	Current detector current rating
MADDT1205	MADDT1205N	50W 100W	1-phase 200V	A	10A	5A
MADDT1207	MADDT1207N	200W	1-phase 200V	A	10A	7.5A
MBDDT2210	MBDDT2210N	400W	1-phase 200V	B	15A	10A
MCDDT3520	MCDDT3520N	750W	Single/3-phase 200V	C	30A	20A
MDDDT5540	MDDDT5540N	1kW 1.5kW		D	50A	40A
MEDDT7364	MEDDT7364N	2kW		E	75A	64A
MFDDTA390	MFDDTA390N	3kW		F	100A	90A
MFDDTB3A2	MFDDTB3A2N	4kW		F	150A	120A
		5kW				



# B Minas A4/A4N Series Servo Drives





## Common Driver Specifications

Basic specifications	Input power	Main circuit	Frame A, B	Single phase, 200–240V	+10% -15%	50/60Hz	
			Frame C, D	Single/3-phase, 200–240V	+10% -15%	50/60Hz	
			Frame E, F	Single/3-phase, 200–240V	+10% -15%	50/60Hz	
		Control circuit	Frame A to D	Single phase, 200–240V	+10% -15%	50/60Hz	
			Frame E, F	Single phase, 200–230V	+10% -15%	50/60Hz	
	Environment	Temperature		Operating: 0 to 55°C , Storage: -20 to +80°C			
		Humidity		Both operating and storage : 90%RH or less (free from condensation)			
		Altitude		1000m or lower			
		Vibration		5.88m/s <sup>2</sup> or less, 10 to 60Hz (no continuous use at resonance frequency)			
	Control method			IGBT PWM sinusoidal wave drive			
Encoder feedback			17-bit (131,072 resolution) absolute/incremental encoder (on demand only) 2500P/r (10,000 resolution) incremental encoder (standard)				
External scale feedback			Compatible with AT500 series, ST771 by Mitsutoyo				
Control signal	Input	10 inputs (1) Servo-ON, (2) Control mode switching, (3) Gain switching/torque limit switching, (4) Alarm clear other inputs vary depending on the control mode, (5) CW drive prohibition, (6) CCW driver prohibition					
	Output	6 outputs (1) Servo alarm, (2) Servo ready, (3) Release signal of external brake (4) Zero speed detection, (5) Torque in-limit. Other outputs vary depending on the control mode					
Analogue signal	Input	3 inputs (16Bit A/D : 1 input, 10Bit A/D : 2 inputs)					
	Output	2 outputs (for monitoring) (1) Speed monitor (actual motor speed or command speed). Select the content and scale with parameter. (2) Torque monitor [torque command (approx. 3V/rated torque)], deviation counter or full- closed deviation is enabled. Select the content or scale with parameter					
Pulse signal	Input	2 inputs Select the exclusive input for line driver or photo-coupler input with parameter					
	Output	4 outputs Feed out the encoder pulse (A, B and Z-phase) or external scale pulse (EXA, EXB and EXZ-phase) in line driver. Z-phase and EXZ-phase pulse is also fed out in open collector					
Communication function	RS232C	1:1 communication to a host with RS232C interface is enabled					
	RS485	1:n communication up to 15 axes to a host with RS485 interface is enabled					
Front panel			(1) 5 keys (MODE, SET, UP, DOWN, SHIFT), (2) LED (6-digit)				
Regeneration			Frame A, B: no built-in regenerative resistor (external resistor only), Frame C to F: built-in regenerative resistor (external resistor is also enabled)				
Dynamic brake			Setup of action sequence at power-OFF, servo-OFF, at protective function activation and over-travel inhibit input is enabled				
Control mode			Switching among the following 7 modes is enabled, (1) Position control, (2) Velocity control, (3) Tor- que control, (4) Position/Velocity control, (5) Position/Torque control, (6) Velocity/Torque control and (7) Full-closed control				



# B Minas A4/A4N Series Servo Drives

## Common Driver Specifications

Functions	Position control	Control input		(1) Deviation counter clear, (2) Command pulse inhibition, (3) Electronic gear switching, (4) Damping control switching	
		Control output		Positioning complete (In-position)	
		Pulse input	Max. command pulse frequency		Exclusive interface for line driver: 2Mpps, Line driver: 500kpps, Open collector: 200kpps
			Input pulse signal format		Support (1) RS422 line drive signal and (2) Open collector signal from controller
			Type of input pulse		Differential input. Selectable with parameter, [(1) CW/CCW, (2) A and B-phase, (3) Command and Direction]
			Electronic gear (division/multiplication of command pulse)		Process the command pulse frequency $\times \frac{(1 \text{ to } 10000) \times 2^{(0-17)}}{1 \text{ to } 10000}$ as a position command input
			Smoothing filter		Primary delay filter or FIR type filter is selectable to the command input
		Analogue input	Torque limit command input		Individual torque limit for both CW and CCW direction is enabled (3V/rated torque)
		Instantaneous speed observer		Usable	
		Damping control		Usable	
	Velocity control	Control input		(1) Zero speed clamp, (2) Selection of internal speed setup, (3) Gain switching or Torque limit switching input	
		Control output		Speed arrival (at-speed)	
		Analogue input	Velocity command input		Setup of scale and rotational direction of the motor against the command voltage is enabled with parameter, with the permissible max. voltage input = 10V and 6V/rated speed (default setup)
			Torque limit command input		Individual torque limit for both CW and CCW direction is enabled (3V/rated torque)
		Speed control range		1 : 5000	
		Internal speed command		8-speed with parameter setup	
		Soft-start/down function		Individual setup of acceleration and deceleration is enabled, with 0 to 10s/1000/min. Sinusoidal acceleration/deceleration is also enabled	
		Zero speed clamp		Zero speed clamp for internal speed command	
		Instantaneous speed observer		Usable	
		Speed command filter		Usable	
	Torque control	Control input		(1) CW over-travel inhibition, (2) CCW over-travel inhibition, (3) Zero speed clamp	
		Control output		Speed arrival (at-speed)	
		Analogue input	Speed command input		Setup of scale and CW/CCW torque generating direction of the motor against the command voltage is enabled with parameter, with the permissible max. voltage input = 10V and 3V/rated speed (default setup)
			Speed limit input		Speed limit input by analogue voltage is enabled. Scale setup with parameter
Speed limit function		Speed limit value with parameter or analogue input is enabled			
Full-closed control	Control input		(1) CW over-travel inhibition, (2) CCW over-travel inhibition, (3) Deviation counter clear, (4) Command pulse input inhibition, (5) Electronic gear switching, (6) Damping control switching		
	Control output		Full-closed positioning complete (in-position)		
	Pulse input	Max. command pulse frequency		Exclusive interface for line driver: 2Mpps, Line driver: 500kpps, Open collector : 200kpps	
		Input pulse signal format		Differential input. Selectable with parameter (1) CCW/CW, (2) A and B-phase, (3) Command and direction	
		Electronic gear division/multiplication of command pulse		Process the command pulse frequency $\times \frac{(1 \text{ to } 10000) \times 2^{(0-17)}}{1 \text{ to } 10000}$ as a position command input	
		Smoothing filter		Primary delay filter is adaptable to the command input	
	Analogue input	Torque limit command input		Individual torque limit for both CW and CCW direction is enabled (3V/rated torque)	
	Setup range of division/multiplication of external scale		Setting of ratio between encoder pulse (denominator) and external scale pulse (numerator) is enabled within a range of $(1 \text{ to } 10000) \times 2^{(0-17)} / (1 \text{ to } 10000)$		
	Common	Auto-gain tuning	Real-time		Corresponds to load inertia fluctuation, possible to automatically set up parameters related to notch filter
			Normal mode		Estimates load inertia and sets up an appropriate servo gain
Fit-gain function			Automatically searches and sets up the value which makes the fastest settling time with external command input		
Masking of unnecessary input		Masking of the following input signal is enabled (1) Over-travel inhibition, (2) Torque limit, (3) Command pulse inhibition, (4) Speed-zero clamp			
Division of encoder feedback pulse		Set up of any value is enabled (encoder pulses count is the max.)			
Protective function		Soft error		Over-voltage, under-voltage, over-speed, over-load, over-heat, over-current and encoder error etc.	
		Hard error		Excess position deviation, command pulse division error, EEPROM error etc.	
Traceability of alarm data		Traceable up to past 14 alarms including the present one			
Damping control function		Manual setup with parameter			
Setup		Manual		5-push switches on front panel     	
	Setup support software		PANATERM® (Supporting OS: Windows95, Windows98, Windows ME, Windows2000, Windows.NET and Windows XP)		



# B Minas A4/A4N Series Servo Drives

## Driver Dimensions

### FRAME A

#### Minas A4N

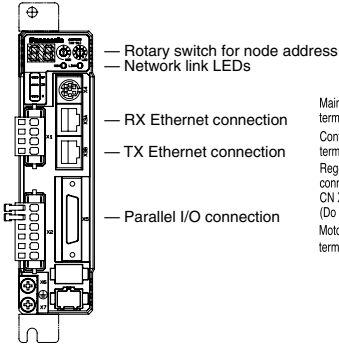

Main power input terminals CN X1  
Control power input terminals CN X1  
Regenerative resistor connecting terminals CN X2 (Do not use R B 3.)  
Motor connecting terminals CN X2

#### Minas A4

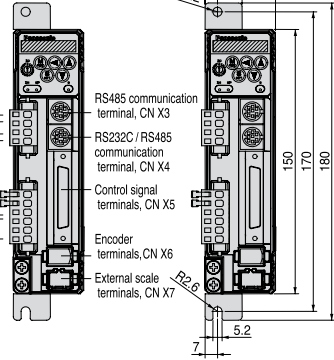

Rack mount type

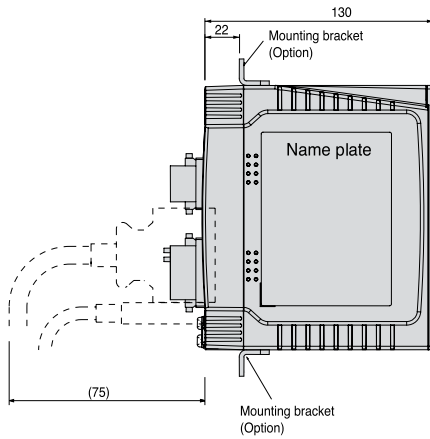

Base mount type (Standard: Back-end mounting)

### FRAME B

#### Minas A4N

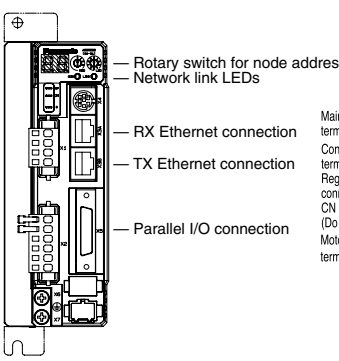

Main power input terminals CN X1  
Control power input terminals CN X1  
Regenerative resistor connecting terminals CN X2 (Do not use R B 3.)  
Motor connecting terminals CN X2

#### Minas A4

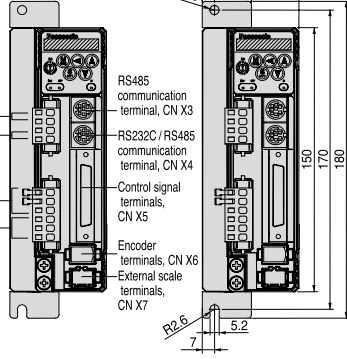

Rack mount type (Option: Front-end mounting)

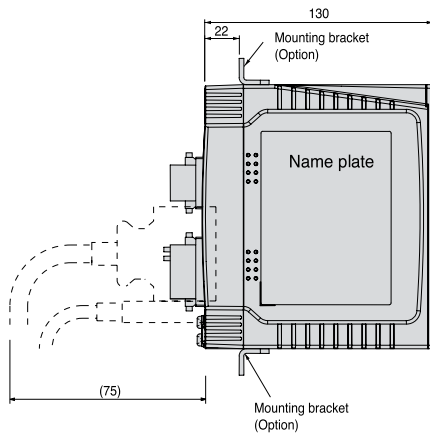

Base mount type (Standard: Back-end mounting)

### FRAME C

#### Minas A4N

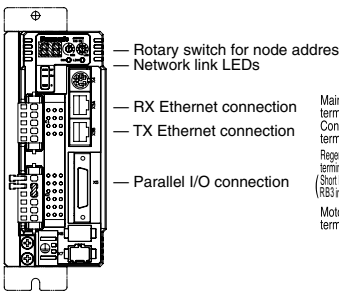

Main power input terminals CN X1  
Control power input terminals CN X1  
Regenerative resistor connecting terminals CN X2 (Short between RB2 and RB3 in normal operation.)  
Motor connecting terminals CN X2

#### Minas A4

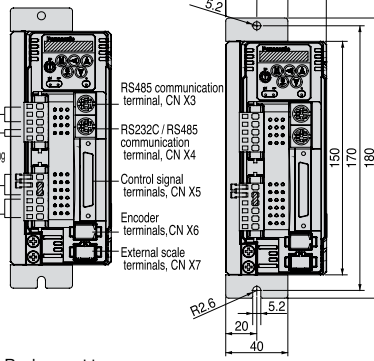

Rack mount type (Option: Front-end mounting)

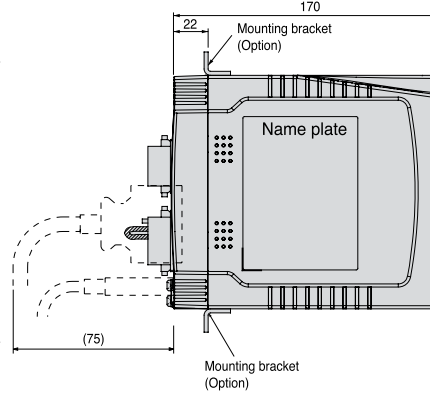

Base mount type (Standard: Back-end mounting)

All measurements in mm



# B Minas A4/A4N Series Servo Drives

## Driver Dimensions

### FRAME D

#### Minas A4N

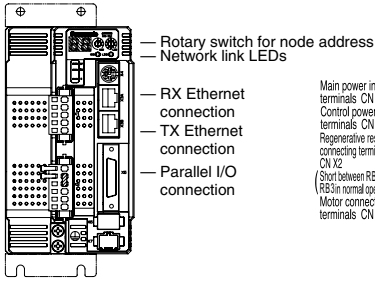

#### Minas A4

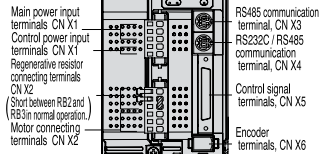

Rack mount type  
(Option: Front-end mounting)

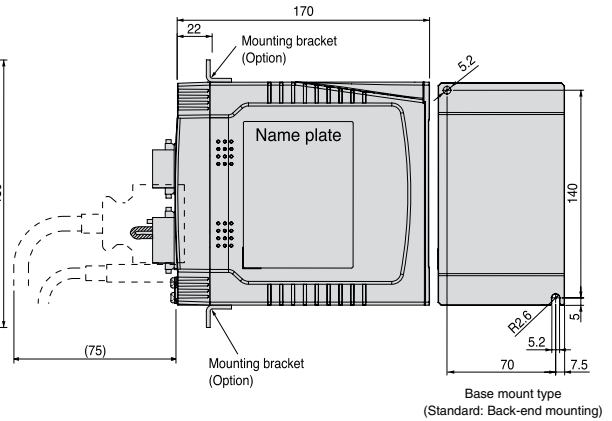
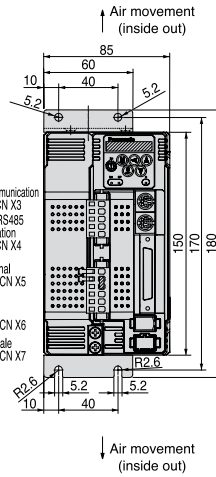

### FRAME E

#### Minas A4N

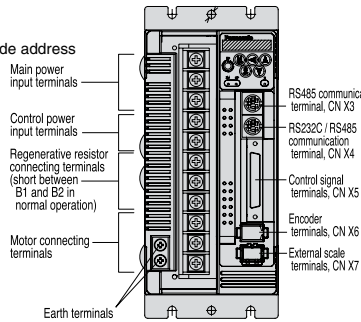
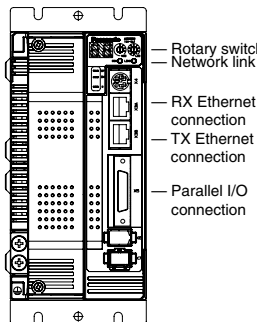

#### Minas A4

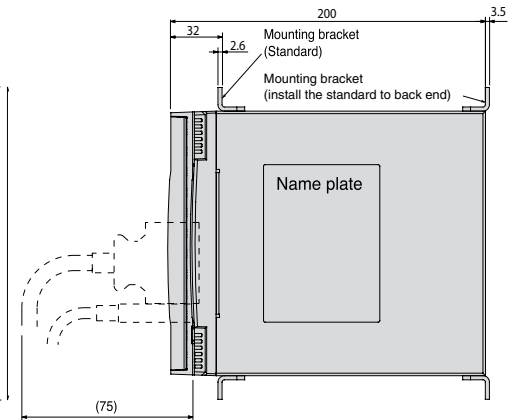
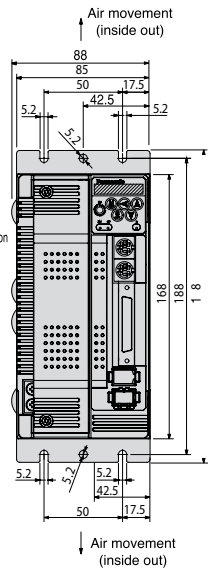

### FRAME F

#### Minas A4N

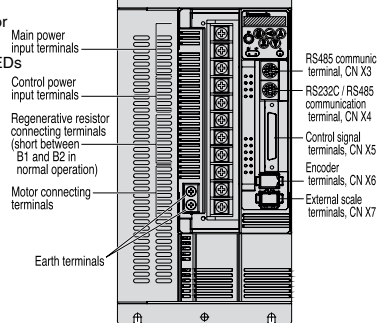
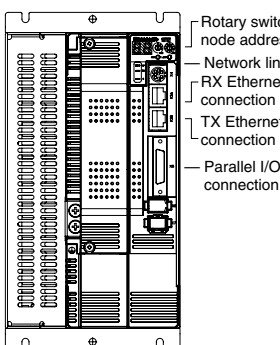

#### Minas A4

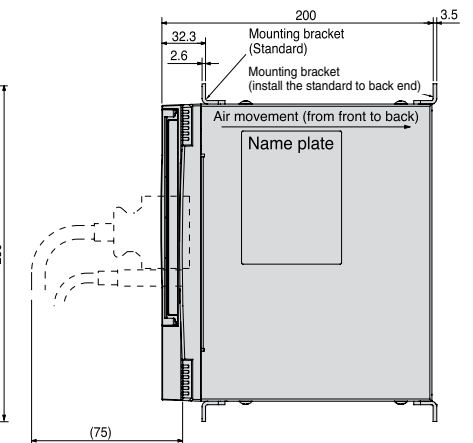
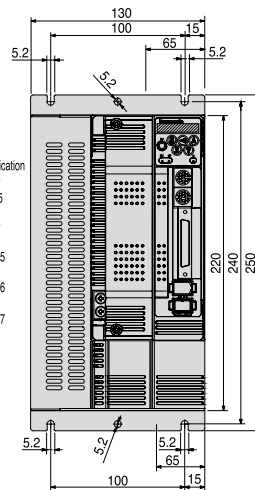

All measurements in mm



# B Minas A4/A4N Series Servo Drives

## Motor Types

Minas A4 series motors, low inertia *								
Rated power	Product no.	Rated torque	Voltage class	Shaft	Oil seal	Brake	IP67 plugs	Encoder
50W	MSMD5AZP1A	0.16Nm	200V	Round				Incremental
	MSMD5AZP1AX			Round			x	
	MSMD5AZP1C			Round	x			
	MSMD5AZP1CX			Round	x		x	
	MSMD5AZP1D			Round	x	x		
	MSMD5AZP1S			Key				
	MSMD5AZP1SX			Key			x	
	MSMD5AZP1T			Key		x		
100W	MSMD012P1A	0.32Nm	200V	Round				Incremental
	MSMD012P1AX			Round			x	
	MSMD012P1C			Round	x			
	MSMD012P1CX			Round	x		x	
	MSMD012P1D			Round	x	x		
	MSMD012P1S			Key				
	MSMD012P1SX			Key			x	
	MSMD012P1T			Key		x		
200W	MSMD022P1A	0.64Nm	200V	Round				Incremental
	MSMD022P1AX			Round			x	
	MSMD022P1C			Round	x			
	MSMD022P1CX			Round	x		x	
	MSMD022P1D			Round	x	x		
	MSMD022P1S			Key				
	MSMD022P1SX			Key			x	
	MSMD022P1T			Key		x		
400W	MSMD042P1A	1.3Nm	200V	Round				Incremental
	MSMD042P1AX			Round			x	
	MSMD042P1C			Round	x			
	MSMD042P1CX			Round	x		x	
	MSMD042P1D			Round	x	x		
	MSMD042P1S			Key				
	MSMD042P1SX			Key			x	
	MSMD042P1T			Key		x		
750W	MSMD082P1A	2.4Nm	200V	Round				Incremental
	MSMD082P1AX			Round			x	
	MSMD082P1C			Round	x			
	MSMD082P1CX			Round	x		x	
	MSMD082P1D			Round	x	x		
	MSMD082P1S			Key				
	MSMD082P1SX			Key			x	
	MSMD082P1T			Key		x		
1.0KW	MSMA102P1G	3.18Nm	200V	Key	x		x	Incremental
	MSMA102P1H			Key	x	x	x	
1.5KW	MSMA152P1G	4.77Nm	200V	Key	x		x	Incremental
	MSMA152P1H			Key	x	x	x	
2.0KW	MSMA202P1G	6.36Nm	200V	Key	x		x	Incremental
	MSMA202P1H			Key	x	x	x	
3.0KW	MSMA302P1G	9.54Nm	200V	Key	x		x	Incremental
	MSMA302P1H			Key	x	x	x	
4.0KW	MSMA402P1G	12.6Nm	200V	Key	x		x	Incremental
	MSMA402P1H			Key	x	x	x	
5.0KW	MSMA502P1G	15.8Nm	200V	Key	x		x	Incremental
	MSMA502P1H			Key	x	x	x	

\* Other types on demand

# B Minas A4/A4N Series Servo Drives

## Motor Specifications

### ■ 50W–750W

		AC200V				
Motor model		MSMD5AZP1 □	MSMD012P1 □	MSMD022P1 □	MSMD042P1 □	MSMD082P1 □
Applicable driver	Model no.	MADDT1205 / MADDT1205N		MADDT1207 (N)	MBDDT2210 (N)	MCDDT3520 (N)
	Frame symbol	Frame A			Frame B	Frame C
Power supply capacity (kVA)		0.3		0.5	0.9	1.3
Rated output (W)		50	100	200	400	750
Rated torque (N • m)		0.16	0.32	0.64	1.3	2.4
Momentary max. peak torque (N • m)		0.48	0.95	1.91	3.8	7.1
Rated current (Arms*)		1.1		1.6	2.6	4
Max. current (Ao-p)		4.7		6.9	11.0	17.0
Regenerative brake frequency (times/min) <sup>1</sup>	Without option	No limit <sup>2</sup>				
	With external brake resistor	No limit <sup>2</sup>				
Rated rotational speed (r/min)		3000				
Max. rotational speed (r/min)		5000				4500
Moment of inertia of rotor (x10 <sup>-4</sup> kg • m <sup>2</sup> )	Without brake	0.025	0.051	0.14	0.26	0.87
	With brake	0.027	0.054	0.16	0.28	0.97
Recommended moment of inertia ratio of the load and the rotor <sup>3</sup>		Smaller than 30 times				Smaller than 20 times
Rotary encoder specifications		2500P/r Incremental				
	Resolution per single turn	10,000				
Protective enclosure rating		IP65 (except shaft through hole and cable end connector)				
Environment	Ambient temperature	0°C to 40°C, storage : -20°C to + 80°C				
	Ambient humidity	85%RH or lower (free of condensation)				
	Installation location	Indoors (no direct sunlight), free from corrosive gas, inflammable gas, oil mist and dust				
	Altitude	1000m or lower				
	Vibration resistance	49m/s <sup>2</sup> or less				
Mass (kg), ( ) represents holding brake type		0.32 (0.53)	0.47 (0.68)	0.82 (1.3)	1.2 (1.7)	2.3 (3.1)
<b>Brake specifications (This brake will be released when it is energized. Do not use this for braking the motor while it is running.)</b>						
Static friction torque (N • m)		0.29		1.27		2.45
Engaging time (ms)		35		50		70
Releasing time (ms) <sup>4</sup>		20 (-)		15 (-)		20 (-)
Operating current (DC) (A)		0.30		0.36		0.42
Releasing voltage		DC 1V or more				
Operating voltage		DC 24V 5%				
<b>Permissible load</b>						
During assembly	Radial load P-direction (N)	147		392		686
	Thrust load A-direction (N)	88		147		294
	Thrust load B-direction (N)	117		196		392
During operation	Radial load P-direction (N)	68		245		392
	Thrust load A-direction (N)	58		98		147
	Thrust load B-direction (N)	58		98		147

For notes 1–4, see page 27  
\*rms = root mean square



# B Minus A4/A4N Series Servo Drives

## Torque Characteristics

### MSMD5AZ□1□

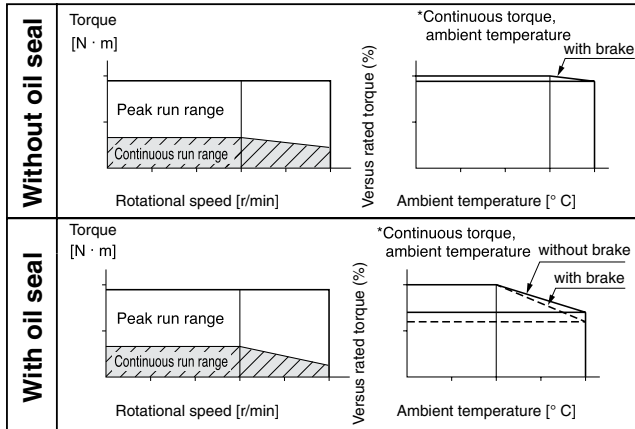

### MSMD012□1□

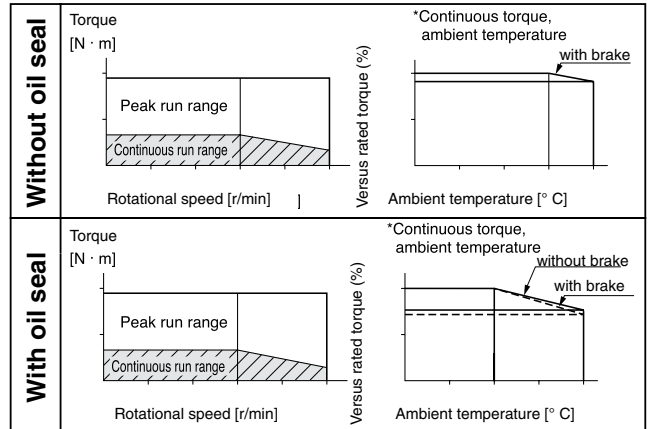

### MSMD022□1□

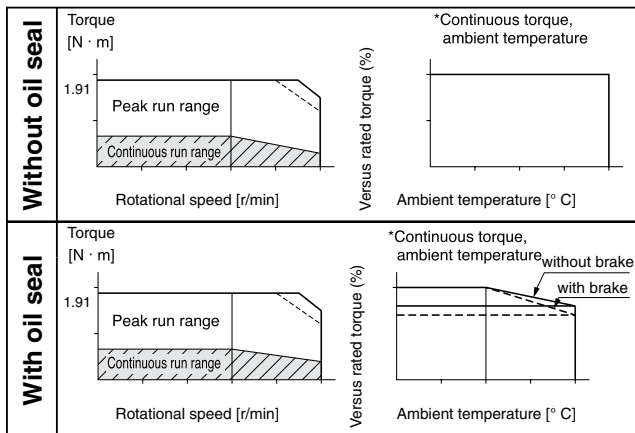

### MSMD042□1□

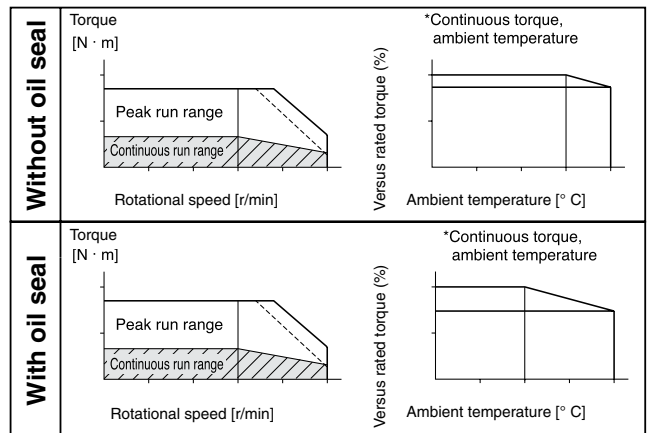

### MSMD082□1□

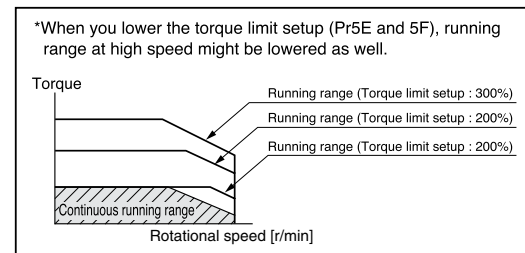
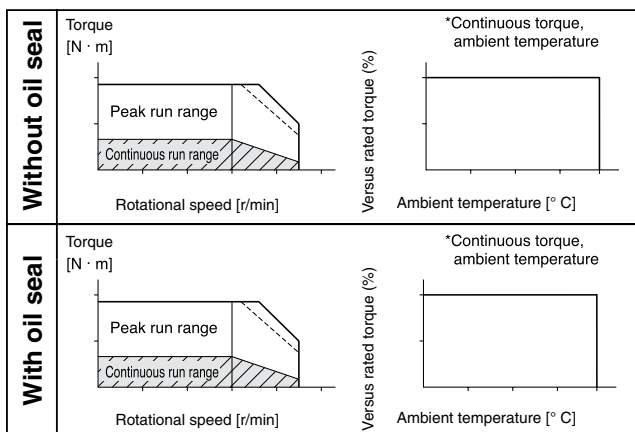



# B Minas A4/A4N Series Servo Drives

## Motor Dimensions

### MSMD 50W–750W (LOW INERTIA)

### HIGH QUALITY CONNECTORS

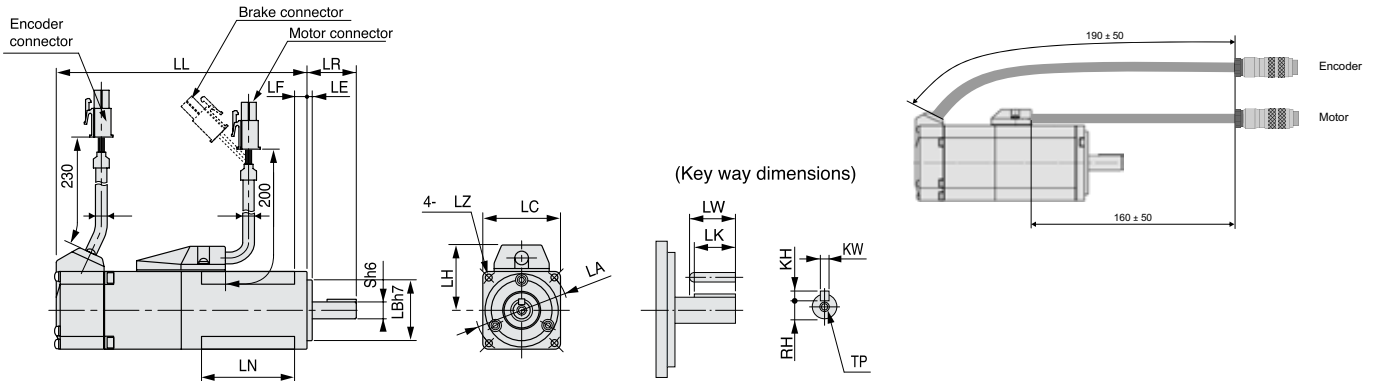

Dimensions are subject to change without notice. Contact us or a dealer for the latest information.

		Minas A4 series (low inertia)					
Motor output		50W	100W	200W	400W	750W	
Motor model		MSMD5AZP1 □	MSMD012P1 □	MSMD022P1 □	MSMD042P1 □	MSMD082P1 □	
Rotary encoder specifications		2500P/r incremental					
LL	Without brake	72	92	79	98.5	112	
	With brake	102	122	115.5	135	149	
LR			25		30	35	
S			8	11	14	19	
LA			45		70	90	
LB			30		50	70	
LC			38		60	80	
LD				—			
LE				3			
LF			6		6.5	8	
LG				—			
LH			32		43	53	
LN		26.5	46.5		—		
LZ			3.4		4.5	6	
Keyway	LW		14	20	25		
	LK		12.5	18	22.5	22	
	KW		3h9	4h9	5h9	6h9	
	KH		3	4	5	6	
	RH		6.2		8.5	11	15.5
	TP		M3 x 6 (depth)		M4 x 8 (depth)	M5 x 10 (depth)	
Mass (kg)	Without brake	0.32	0.47	0.82	1.2	2.3	
	With brake	0.53	0.68	1.3	1.7	3.1	



# B Minas A4/A4N Series Servo Drives

## Motor Specification

### 1kW–5kW

		AC200V					
Motor model		MSMA102P1□	MSMA152P1□	MSMA202P1□	MSMA302P1□	MSMA402P1□	MSMA502P1□
Applicable driver	Model no.	MDDDT5540/N		MEDDT7364/N	MFDDTA390/N	MFDDTB3A2/N	
	Frame symbol	Frame D		Frame E	Frame F		
Power supply capacity (kVA)		1.8	2.3	3.3	4.5	6.0	7.5
Rated output (W)		1000	1500	2000	3000	4000	5000
Rated torque (N • m)		3.18	4.77	6.36	9.54	12.6	15.8
Momentary max. peak torque (N • m)		9.5	14.3	19.1	28.6	37.9	47.6
Rated current (Arms*)		7.2	9.4	13.0	18.6	24.7	28.5
Max. current (Ao-p)		30	40	56	80	105	120
Regenerative brake frequency (times/min) <sup>1</sup>	Without option	No limit <sup>2</sup>					
	With external brake resistor	—				No limit <sup>2</sup>	
		No limit <sup>2</sup>					
Rated rotational speed (r/min)		3000					
Max. rotational speed (r/min)		5000				4500	
Moment of inertia of rotor (x10-4 kg • m <sup>2</sup> )	Without brake	1.69	2.59	3.46	6.77	12.7	17.8
	With brake	1.88	2.84	3.81	7.45	14.1	19.7
Recommended moment of inertia ratio of the load and the rotor <sup>3</sup>		Smaller than 15 times					
Rotary encoder specifications		2500P/r Incremental					
	Resolution per single turn	10,000					
Protective enclosure rating		IP65 (except shaft through hole and cable end connector)					
Environment	Ambient temperature	0°C to 40°C (free from freezing), Storage : -20°C to + 80°C					
	Ambient humidity	85%RH or lower (free from condensing)					
	Installation location	Indoors (no direct sunlight), free from corrosive gas, inflammable gas, oil mist and dust					
	Altitude	1000m or lower					
	Vibration resistance	49m/s <sup>2</sup> or less					
Mass (kg), ( ) represents holding brake type		4.5 (5.1)	5.1 (6.5)	6.5 (7.9)	9.3 (11.0)	12.9 (14.8)	17.3 (19.2)
<b>Brake specifications (This brake will be released when it is energized. Do not use this for braking the motor in motion.)</b>							
Static friction torque (N • m)		4.9	7.8		11.8	16.1	
Engaging time (ms)		50			80	110	
Releasing time (ms) <sup>4</sup>		15 (100)				50 (130)	
Operating current (DC) (A)		0.74	0.81		0.81	0.90	
Releasing voltage		DC 2V or more					
Operating voltage		DC 24V 10%					
<b>Permissible load</b>							
During assembly	Radial load P-direction (N)	686			980		
	Thrust load A-direction (N)	392			588		
	Thrust load B-direction (N)	490			686		
During operation	Radial load P-direction (N)	392		490		784	
	Thrust load A-direction (N)	147		196		343	
	Thrust load B-direction (N)	147		196		343	

For notes 1–4 see Page 27  
\*rms= root mean square

# B Minas A4/A4N Series Servo Drives

## Motor Characteristics 1kW to 5kW

### MSMA102□1□

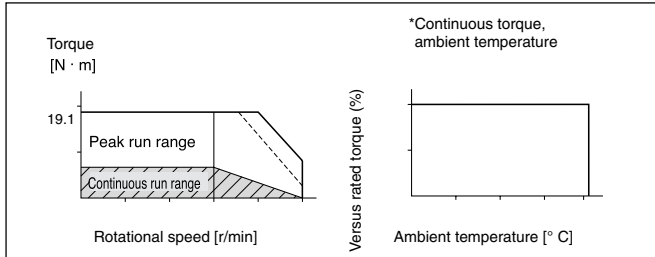

### MSMA152□1□

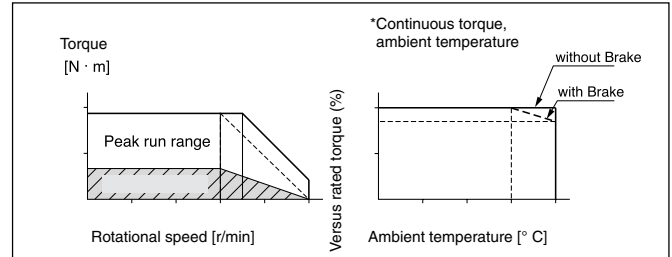

### MSMA202□1□

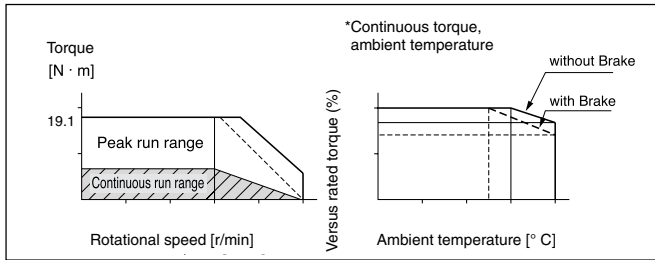

### MSMA302□1□

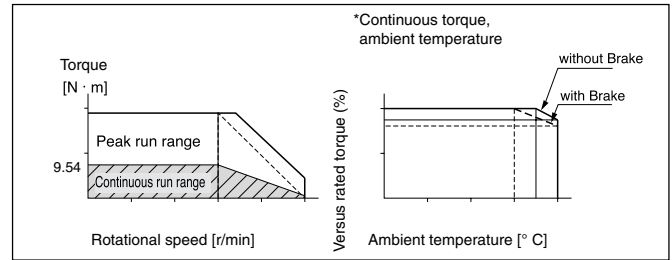

### MSMA402□1□

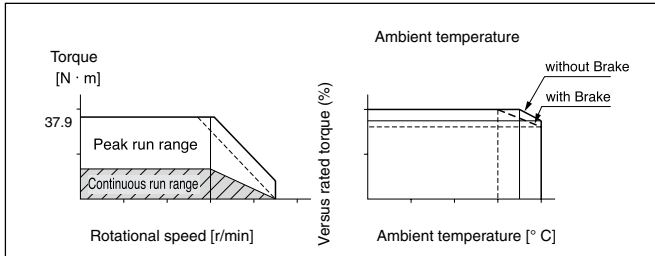

### MSMA502□1□

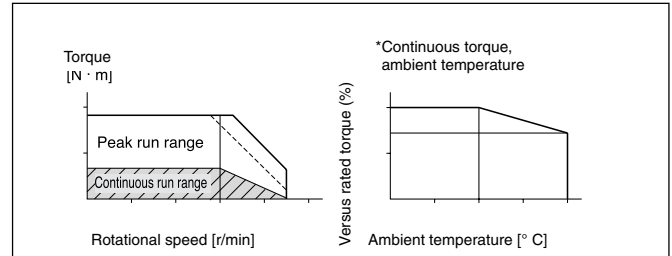

\*When you lower the torque limit setup (Pr5E and 5F), running range at high speed might be lowered as well.

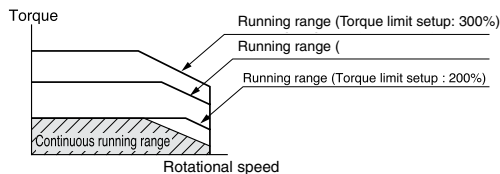

#### Notes:

- Regenerative brake frequency represents the frequency of the motor's stops from the rated speed with deceleration without load.
  - If the load is connected, frequency will be defined as  $1/(m+1)$ , where  $m$ =load moment of inertia/rotor moment of inertia.
  - When the motor speed exceeds the rated speed, regenerative brake frequency is in inverse proportion to the square of (running speed/rated speed).
  - Power supply voltage is AC230V (at 200V of the main voltage). If the supply voltage fluctuates, frequency is in inverse proportion to the square of (running supply voltage/230) relative to the value in the table.
  - When regeneration occurs continuously, e.g. frequent changes in running speed or vertical feeding, consult either us or a dealer.

Radial load (P) direction

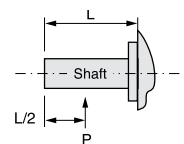

Thrust load (A, B) direction

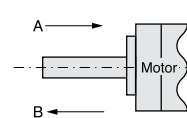

- If the effective torque is within the rated torque, there is no limit in generative brake.
- Consult us or a dealer if the load moment of inertia exceeds the specified value.
- Specified releasing time is obtained with the use of surge absorber for brake (Z15D151 by Ishizuka Electronic or equivalent).
- ( ) Represents the actually measured value using a diode (200V, 1A or equivalent).



# B Minas A4/A4N Series Servo Drives

## Motor Dimensions

### MSMA 1kW–5kW (LOW INERTIA)

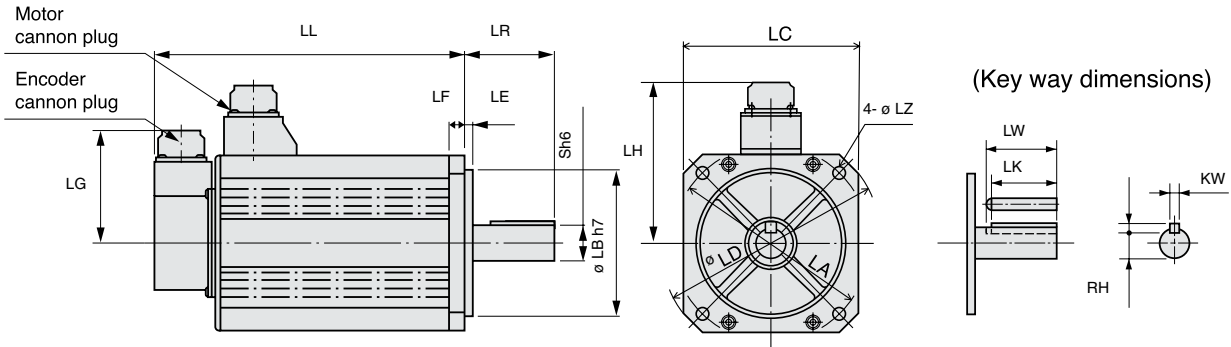

Dimensions are subject to change without notice. Contact us or a dealer for the latest information.

		Minas A4 series (low inertia)					
Motor output		1.0kW	1.5kW	2.0kW	3.0kW	4.0kW	5.0kW
Motor model		MSMA102P1□	MSMA152P1□	MSMA202P1□	MSMA302P1□	MSMA402P1□	MSMA502P1□
Rotary encoder specifications		2500P/r incremental					
LL	Without brake	175	180	205	217	240	280
	With brake	200	205	230	242	265	305
LR			55		55		65
S			19		22		24
LA		100		115	130/145 (slot)		145
LB		80		95		110	
LC		90		100	120		130
LD		120		135	162		165
LE				3			6
LF		7		10		12	
LG					84		
LH		98		103	111		118
LZ		6.6			9		
Key way	LW			45			55
	LK			42	41		51
	KW			6h9		8h9	
	KH			6		7	
	RH			15.5	18		20
Mass (kg)	Without brake	4.5	5.1	6.5	9.3	12.9	17.3
	With brake	5.1	6.5	7.9	11.0	14.8	19.2
Connector/Plug specifications		Refer to Minas A4 Manual					



# © Software

## Setup Support Software

### ■ SETUP SUPPORT SOFTWARE PANATERM® FOR MINAS SERIES AC SERVO MOTOR & DRIVER

PANATERM® assists users in setting parameters, monitoring control conditions, setup support and analysing mechanical operation data on the PC screen when installed in a commercially available personal computer and connected to the MINAS series through the RS232C serial interface.



### ■ BASIC FUNCTION

#### Parameter setup

- After a parameter has been defined on the screen, it will immediately be sent to the driver.
- Once you register the parameters you frequently use, they can easily be set up on the screen.

### ■ MONITORING CONTROL CONDITIONS

#### Monitor

- Control conditions: control mode, velocity, torque, error and warning.
- Driver input signal.
- Load conditions: total count of command/feedback pulses, load ratio, regenerative resistor load ratio.

#### Alarm

- Displays the numbers and contents of the current alarm and a history of the last 14 error events.
- Clears the numbers and contents of the current alarm and a history of the last 14 error events.

### ■ SETUP

#### Auto tuning

- Gain adjustment and inertia ratio measurement.

#### Graphic waveform display

- The graphic display shows command velocity, actual velocity, torque, and error waveforms.

#### Absolute encoder setup

- Clears absolute encoder at the origin.
- Displays single revolution/multirevolution data.
- Displays absolute encoder status.

### ■ ANALYSIS OF MECHANICAL OPERATION DATA

#### Frequency analysis

- Measures frequency characteristics of the machine; displays Bode diagram.

Product No. DVOP4460

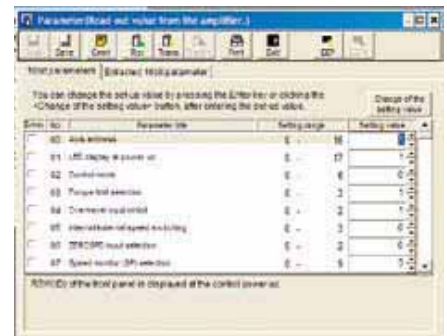

Parameter

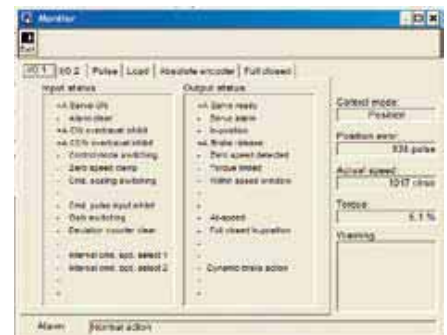

Monitor

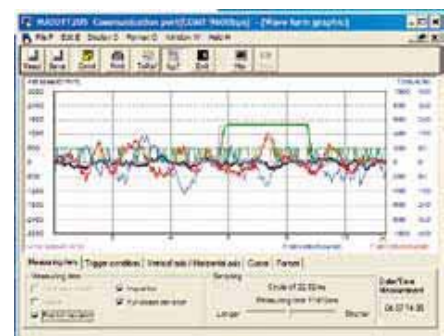

Graphic waveform display



# Accessories

## Encoder Cables, Motor and Brake Cables

### ENCODER CABLES

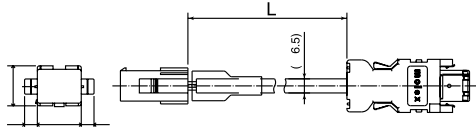

MFECA0□□0EAM

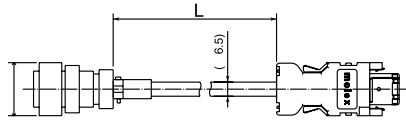

MFECA0□□0ESD

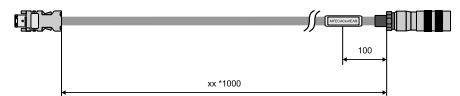

MFECA0□□0EAB

PN	Power range	Length	IP class	Drag chain usage	Power supply	Additional information
MFECA0010EAM	50–750W	1m		Possible	1/3–200VAC	
MFECA0020EAM	50–750W	2m		Possible	1/3–200VAC	
MFECA0030EAM	50–750W	3m		Possible	1/3–200VAC	
MFECA0050EAM	50–750W	5m		Possible	1/3–200VAC	
MFECA0100EAM	50–750W	10m		Possible	1/3–200VAC	
MFECA0020EAB	50–750W	2m	IP67	Possible	1/3–200VAC	High quality connector
MFECA0030EAB	50–750W	3m	IP67	Possible	1/3–200VAC	High quality connector

PN	Power range	Length	IP class	Drag chain usage	Power supply	Additional information
MFECA0040EAB	50–750W	4m	IP67	Possible	1/3–200VAC	High quality connector
MFECA0050EAB	50–750W	5m	IP67	Possible	1/3–200VAC	High quality connector
MFECA0100EAB	50–750W	10m	IP67	Possible	1/3–200VAC	High quality connector
MFECA0150EAB	50–750W	15m	IP67	Possible	1/3–200VAC	High quality connector
MFECA0030ESD	1–5kW	3m	IP67	Possible	1/3–200VAC	Canon plug
MFECA0050ESD	1–5kW	5m	IP67	Possible	1/3–200VAC	Canon plug
MFECA0100ESD	1–5kW	10m	IP67	Possible	1/3–200VAC	Canon plug

### MOTOR CABLES

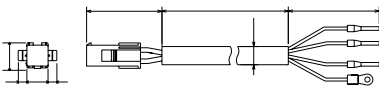

MFMCA0□□0EED

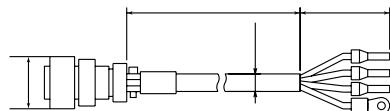
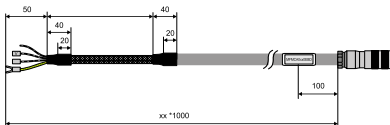

MFMCD0□□2ECD    MFMCD0□□2ECT

### MOTOR CABLE (WITH BRAKE)

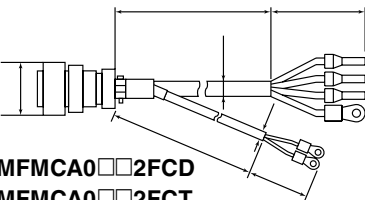

MFMCA0□□2FCD  
MFMCA0□□2FCT

### BRAKE CABLE

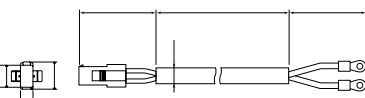

MFMCB0□□0GET

PN	Power range	Length	IP class	Drag chain usage	Power supply	Additional information
<b>Motor cables</b>						
MFMCA0010EED	50–750W	1m		Possible	1–230VAC	
MFMCA0020EED	50–750W	2m		Possible	1–230VAC	
MFMCA0030EED	50–750W	3m		Possible	1–230VAC	
MFMCA0050EED	50–750W	5m		Possible	1–230VAC	
MFMCA0100EED	50–750W	10m		Possible	1–230VAC	
MFMCA0020EBD	50–750 W	2m	IP67	Possible	1–230VAC	High quality connector
MFMCA0030EBD	50–750W	3m	IP67	Possible	1–230VAC	High quality connector
MFMCA0040EBD	50–750W	4m	IP67	Possible	1–230VAC	High quality connector
MFMCA0050EBD	50–750W	5m	IP67	Possible	1–230VAC	High quality connector
MFMCA0100EBD	50–750 W	10m	IP67	Possible	1–230VAC	High quality connector
MFMCA0150EBD	50–750 W	15m	IP67	Possible	1–230VAC	High quality connector
MFMCD0032ECD	1–1.5kW	3m	IP67	Possible	1–230VAC	
MFMCD0052ECD	1–1.5kW	5m	IP67	Possible	1–230VAC	
MFMCD0102ECD	1–1.5kW	10m	IP67	Possible	1–230VAC	
MFMCD0032ECT	2kW	3m	IP67	Possible	1–230VAC	
MFMCD0052ECT	2kW	5m	IP67	Possible	1–230VAC	
MFMCD0102ECT	2kW	10m	IP67	Possible	1–230VAC	
MFMCA0033ECT	3–5kW	3m	IP67	Possible	1–230VAC	
MFMCA0053ECT	3–5kW	5m	IP67	Possible	1–230VAC	
MFMCA0103ECT	3–5kW	10m	IP67	Possible	1–230VAC	
<b>Motor cables (with brake)</b>						
MFMCA0032FCD	1–1.5kW	3m	IP67	Possible	1–230VAC	For motors with holding brake
MFMCA0052FCD	1–1.5kW	5m	IP67	Possible	1–230VAC	For motors with holding brake
MFMCA0102FCD	1–1.5kW	10m	IP67	Possible	1–230VAC	For motors with holding brake
MFMCA0032FCT	2kW	3m	IP67	Possible	1–230VAC	For motors with holding brake
MFMCA0052FCT	2kW	5m	IP67	Possible	1–230VAC	For motors with holding brake
MFMCA0102FCT	2kW	10m	IP67	Possible	1–230VAC	For motors with holding brake
MFMCA0033FCT	3–5kW	3m	IP67	Possible	1–230VAC	For motors with holding brake
MFMCA0053FCT	3–5kW	5m	IP67	Possible	1–230VAC	For motors with holding brake
MFMCA0103FCT	3–5kW	10m	IP67	Possible	1–230VAC	For motors with holding brake
<b>Brake cables</b>						
MFMCB0050GET	30–750W	5m		Possible	1/3–200VAC	
MFMCB0100GET	30–750W	10m		Possible	1/3–200VAC	