

# 3-phase Motor

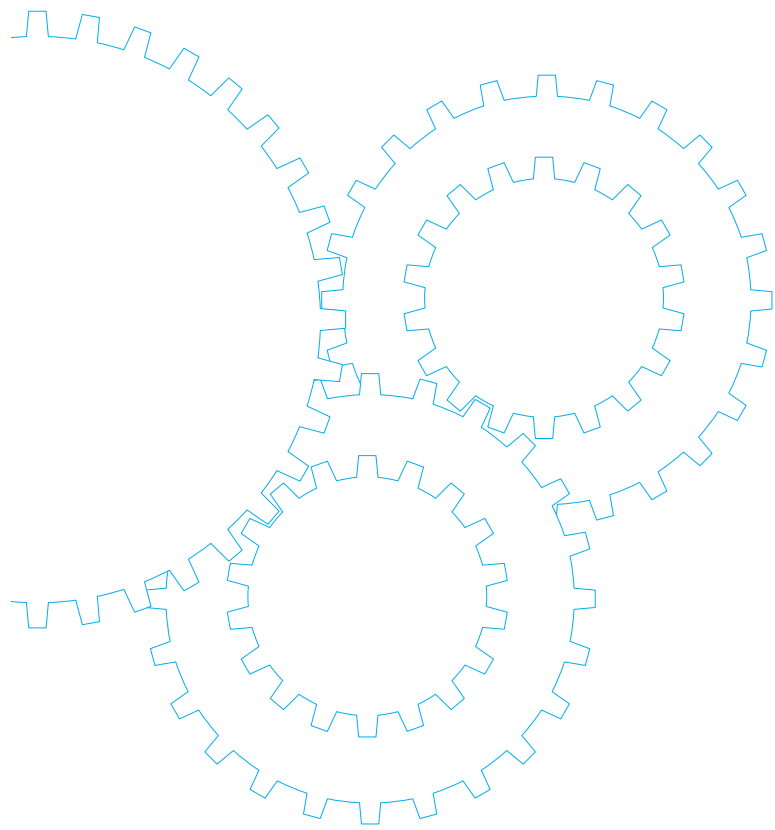

## Contents

- Motor Overview B-126
- Model list B-128
- Product information for each model B-130
- Gear head combination dimensions B-162
- Round shaft motor dimensions B-164

# Outline of 3-phase motor

## Features

- The 3-phase motor is an induction motor for 3-phase power.
- Continuous time rating
- The motor with national specifications is of heatproof class 120 (E); the motor with specifications compliant with overseas standards is of heatproof class 130 (B).

## Construction

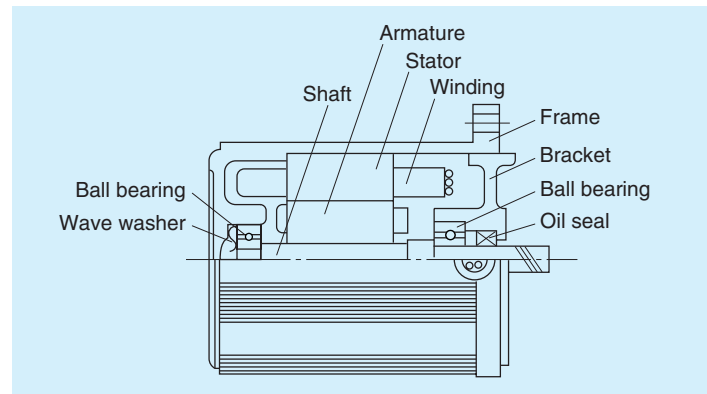

## Characteristics

- Speed-torque characteristics

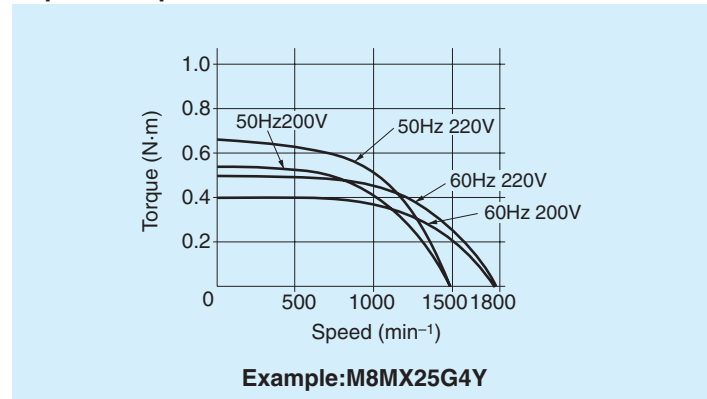

## System configuration diagram

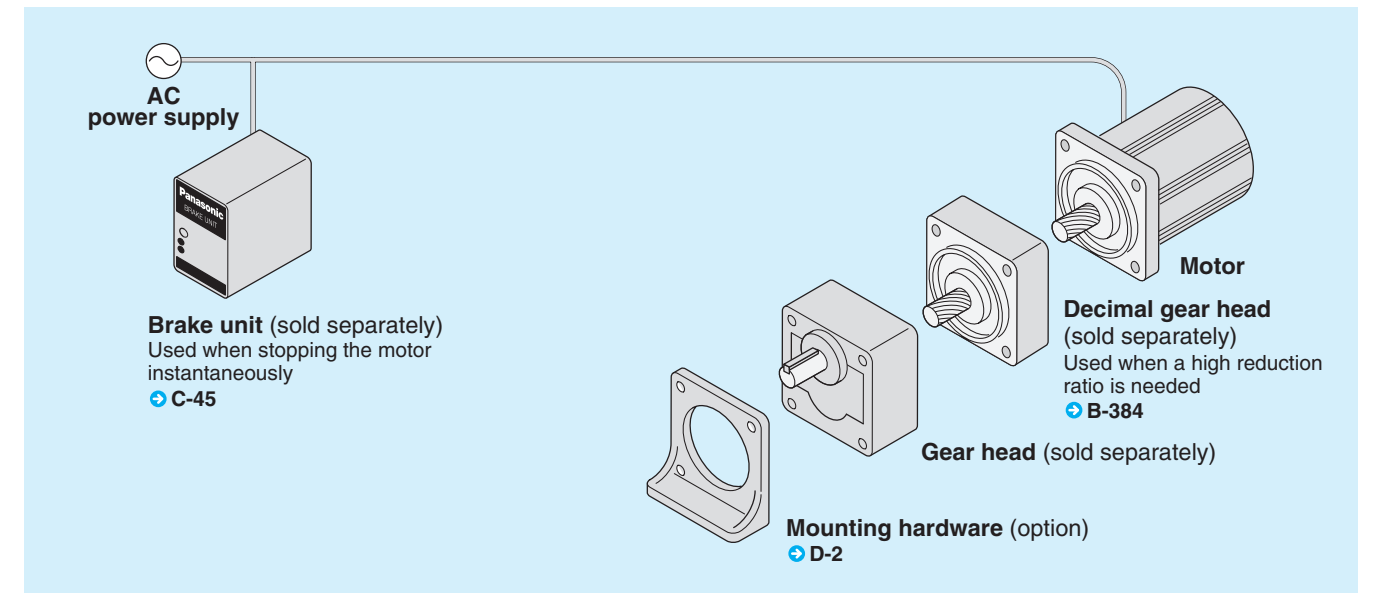

## Coding system

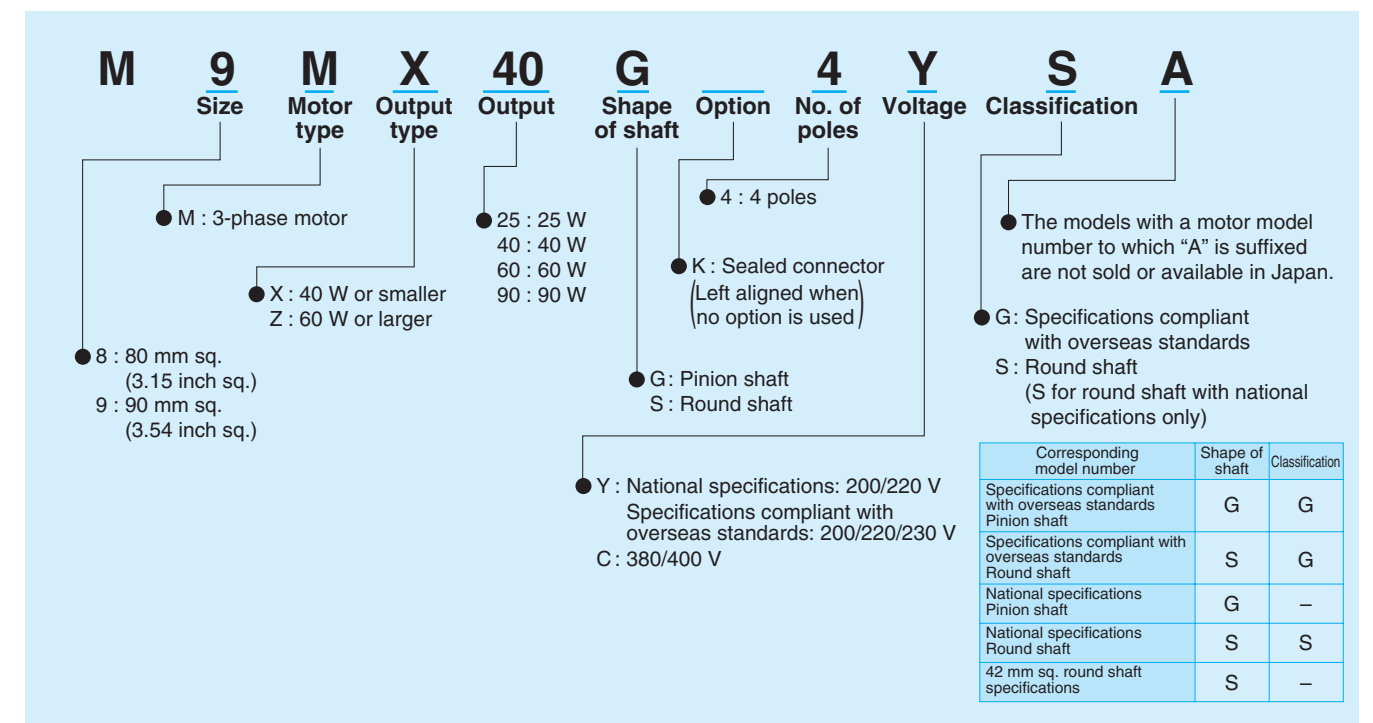

## Fit tolerance

Fit tolerance symbol is used in the outside dimension diagram of motor and gear head. For further information, see "Fit tolerance" on page A-33.

# Model list of 3-phase motor

## Pinion shaft motor

★ Motor compliant with overseas standards c   

Size	Output (W)	Leadwire type			Sealed connector type		
		Model number	Specifications	Page	Model number	Specifications	Page
80 mm sq. (3.15 inch sq.)	25	M8MX25G4Y	200/220V	B-130	M8MX25GK4Y	200/220V	B-146
		M8MX25G4YG(A)	200/220/230V ★	B-132	M8MX25GK4YG(A)	200/220/230V ★	B-148
					M8MX25GK4CG(A)	380/400V ★	B-148
90 mm sq. (3.54 inch sq.)	40	M9MX40G4Y	200/220V	B-134	M9MX40GK4Y	200/220V	B-150
		M9MX40G4YG(A)	200/220/230V ★	B-136	M9MX40GK4YG(A)	200/220/230V ★	B-152
					M9MX40GK4CG(A)	380/400V ★	B-152
	60	M9MZ60G4Y	200/220V	B-138	M9MZ60GK4Y	200/220V	B-154
		M9MZ60G4YG(A)	200/220/230V ★	B-140	M9MZ60GK4YG(A)	200/220/230V ★	B-156
					M9MZ60GK4CG(A)	380/400V ★	B-156
90	M9MZ90G4Y	200/220V	B-142	M9MZ90GK4Y	200/220V	B-158	
	M9MZ90G4YG(A)	200/220/230V ★	B-144	M9MZ90GK4YG(A)	200/220/230V ★	B-160	
				M9MZ90GK4CG(A)	380/400V ★	B-160	

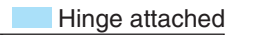

## Applicable gear head

 Hinge attached

Standard gear head		High torque gear head	Right-angle gear head	Gear head -Inch (U.S.A.)	Decimal gear head
Ball bearing	metal bearing				
MX8G□B	MX8G□M	—	—	MX9G□BU	MX8G10XB
MX9G□B	MX9G□M	—	MX9G□R	MX9G□BU	MX9G10XB
MZ9G□B	—	MR9G□B	MZ9G□R	MZ9G□BU	MZ9G10XB
MY9G□B	—	MP9G□B			

\* Refer to page B-444 for dimensions and permissible torque of high torque gear head.  
 Refer to page B-446 for dimensions and permissible torque of right-angle gear head.  
 Refer to page B-451 for dimensions and permissible torque of gear head -Inch (U.S.A.).  
 Refer to page B-448 for dimensions of decimal gear head.

## Round shaft motor

★ Motor compliant with overseas standards c     
 Ⓢ Electrical Appliance and Material Safety Law

Size	Output (W)	Leadwire type		Sealed connector type	
		Model number	Specifications	Model number	Specifications
80 mm sq. (3.15 inch sq.)	25	M8MX25S4YS	200/220V	M8MX25SK4YS	200/220V Ⓢ
		M8MX25S4YG(A)	200/220/230V ★	M8MX25SK4YG(A)	200/220/230V ★ Ⓢ
				M8MX25SK4CG(A)	380/400V ★
90 mm sq. (3.54 inch sq.)	40	M9MX40S4YS	200/220V	M9MX40SK4YS	200/220V Ⓢ
		M9MX40S4YG(A)	200/220/230V ★	M9MX40SK4YG(A)	200/220/230V ★ Ⓢ
				M9MX40SK4CG(A)	380/400V ★
	60	M9MZ60S4YS	200/220V	M9MZ60SK4YS	200/220V Ⓢ
		M9MZ60S4YG(A)	200/220/230V ★	M9MZ60SK4YG(A)	200/220/230V ★ Ⓢ
				M9MZ60SK4CG(A)	380/400V ★
90	M9MZ90S4YS	200/220V	M9MZ90SK4YS	200/220V Ⓢ	
	M9MZ90S4YG(A)	200/220/230V ★	M9MZ90SK4YG(A)	200/220/230V ★ Ⓢ	
			M9MZ90SK4CG(A)	380/400V ★	

\* The specifications and wire connections of the round shaft motor are the same as those of the pinion shaft motor.  
 Dimensional outline drawing → Page B-164.

### <Notice>

380V/400V 3-phase round shaft motors with a sealed connector are not covered by the Electrical Appliance and Material Safety Law.

## Specifications

Size	Motor model No.	Number of pole (P)	Output (W)	Voltage (V)	Frequency (Hz)	Rating (min)	Rating				Starting current (A)	Starting torque N-m (oz-in)
							Input (W)	Current (A)	Speed (min <sup>-1</sup> )	Torque N-m (oz-in)		
80 mm sq.	M8MX25G4Y	4	25	200	50	Cont.	50	0.25	1350	0.18 (25.5)	0.62	0.54 (76.5)
						Cont.	47	0.22	1625	0.15 (21.2)	0.58	0.40 (56.6)
				220	60	Cont.	54	0.27	1375	0.18 (25.5)	0.67	0.66 (93.5)
						Cont.	49	0.23	1650	0.15 (21.2)	0.64	0.50 (70.8)

\* The specifications and wire connections of the round shaft motor are the same as those of the pinion shaft type. For the dimensional outline drawing, refer to page B-164.

## Permissible torque at output shaft of gear head

\* The speed shown below is a calculated value based on the synchronous rotational speed. Depending on the load, the speed is less than the indicated value by 2 to 20%.

Unit of permissible torque: upper (N·m) / lower (lb-in)

Reduction ratio		3	3.6	5	6	7.5	9	10	12.5	15	18	20	25	30	36	50	60	75	90	100	120	150	180	
Speed (min <sup>-1</sup> )	50Hz	500	416.7	300	250	200	166.7	150	120	100	83.3	75	60	50	41.7	30	25	20	16.7	15	12.5	10	8.3	
	60Hz	600	500	360	300	240	200	180	144	120	100	90	72	60	50	36	30	24	20	18	15	12	10	
Applicable gear head	MX8G3B to MX8G180B (ball bearing)	0.39 (3.45)	0.47 (4.16)	0.66 (5.84)	0.78 (6.90)	0.98 (8.67)	1.18 (10.4)	1.27 (11.2)	1.57 (13.9)	1.96 (17.3)	2.35 (20.8)	2.55 (22.6)	3.14 (27.8)	3.82 (33.8)	4.61 (40.8)	6.37 (56.4)	7.64 (67.6)							7.84 (69.4)
	MX8G3M to MX8G180M (metal bearing)	0.32 (2.83)	0.39 (3.45)	0.55 (4.87)	0.66 (5.84)	0.81 (7.17)	0.98 (8.67)	1.08 (9.56)	1.27 (11.2)	1.57 (13.9)	1.96 (17.3)	2.06 (18.2)	2.65 (23.5)	3.14 (27.8)	3.82 (33.8)	5.29 (46.8)	6.37 (56.4)							7.84 (69.4)
Rotational direction		Same as motor rotational direction											Reverse to motor rotational direction											

## Permissible torque at output shaft of gear head using decimal gear head

Applicable gear head		Reduction ratio		200	250	300	360	500	600	750	900	1000	1200	1500	1800
Bearing	Decimal gear head	Speed (min <sup>-1</sup> )	50Hz	7.5	6	5	4.2	3	2.5	2	1.7	1.5	1.3	1	0.8
			60Hz	9	7.2	6	5	3.6	3	2.4	2	1.8	1.5	1.2	1
MX8G□B (ball bearing) MX8G□M (metal bearing)	MX8G10XB	Permissible torque	N·m (lb-in)	7.84 (69.4)	7.84 (69.4)	7.84 (69.4)	7.84 (69.4)	7.84 (69.4)	7.84 (69.4)	7.84 (69.4)	7.84 (69.4)	7.84 (69.4)	7.84 (69.4)	7.84 (69.4)	7.84 (69.4)
		Rotational direction		Same as motor rotational direction	Reverse to motor rotational direction										

## Connection diagram

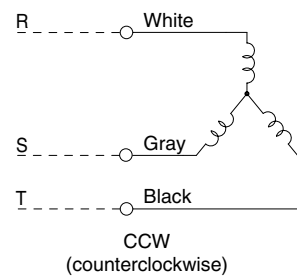

Change any two lead wires of R, S and T for CW rotation.

## Speed-torque characteristics

### M8MX25G4Y

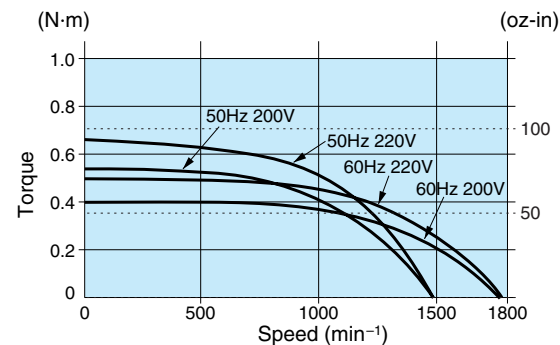

## Motor (dimensions)

Scale: 1/3, Unit: mm (inch)

M8MX25G4Y 4P 25 W 200 V / 220 V

Mass 1.5 kg (3.31 lb)  
Helical gear  
Module 0.5  
Number of teeth 9

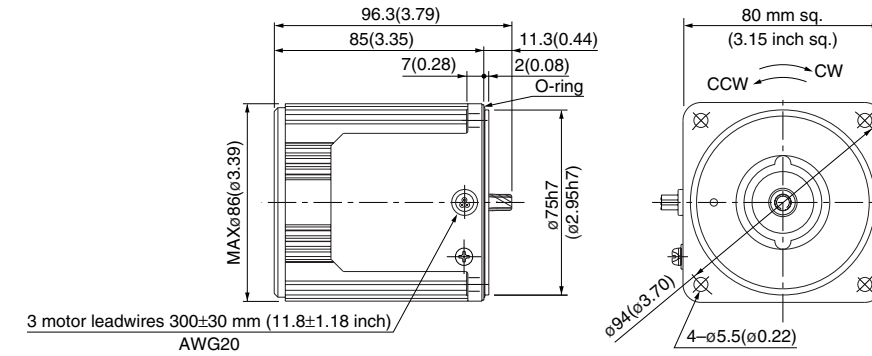

\* Diameter of applicable cable to be ø8(ø0.31) to ø12(ø0.47).

## Gear head (dimensions)

Scale: 1/3, Unit: mm (inch)

MX8G□B (ball bearing) / MX8G□M (metal bearing) Mass 0.6 kg (1.32 lb)

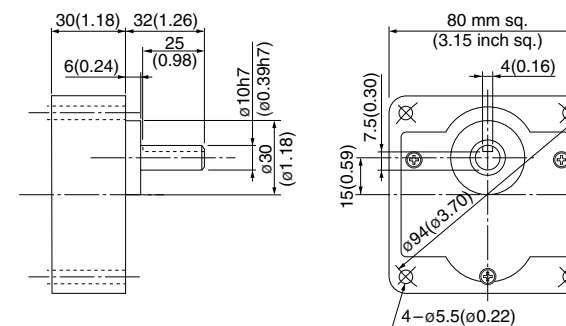

## Key and keyway (dimensions) [attachment]

MX8G□B(M)

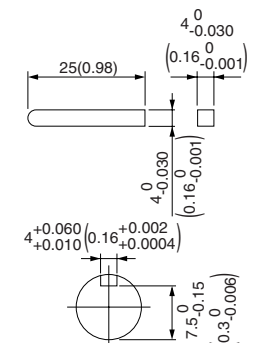

\* Please read your User's manual carefully so that you will understand the operation and safety precautions before attempting to operate the system.

(Note) Because the dimensions may be subject to change, also check the determinate dimensions if the gear head is to be used for design.

# 3-phase motor (leadwire)

**80 mm (3.15 inch) sq. 25 W**

## Specifications

Size	Motor model No.	Number of pole (P)	Output (W)	Voltage (V)	Frequency (Hz)	Rating (min)	Rating				Starting current (A)	Starting torque N-m (oz-in)
							Input (W)	Current (A)	Speed (min <sup>-1</sup> )	Torque N-m (oz-in)		
80 mm sq.	<b>M8MX25G4YG</b> <b>M8MX25G4YGA</b>	4	25	200	50	Cont.	50	0.25	1350	0.18 (25.5)	0.62	0.54 (76.5)
							47	0.22	1625	0.15 (21.2)	0.58	0.40 (56.6)
							49	0.23	1650	0.14 (19.8)	0.64	0.50 (70.8)
							50	0.24	1675	0.14 (19.8)	0.65	0.54 (76.5)

• The specifications and wire connections of the round shaft motor are the same as those of the pinion shaft type. For the dimensional outline drawing, refer to page B-164.  
 • The models with a motor model number to which "A" is suffixed are not sold or available in Japan.

## Permissible torque at output shaft of gear head

\* The speed shown below is a calculated value based on the synchronous rotational speed. Depending on the load, the speed is less than the indicated value by 2 to 20%.

Unit of permissible torque: upper (N·m) / lower (lb-in)

Reduction ratio	3 3.6 5 6 7.5 9 10 12.5 15 18 20 25 30 36 50 60 75 90 100 120 150 180																					
	Speed (min <sup>-1</sup> )																					
50Hz	500	416.7	300	250	200	166.7	150	120	100	83.3	75	60	50	41.7	30	25	20	16.7	15	12.5	10	8.3
	600	500	360	300	240	200	180	144	120	100	90	72	60	50	36	30	24	20	18	15	12	10
Applicable gear head	MX8G3B to MX8G180B (ball bearing)																					
	50Hz	0.39 (3.45)	0.47 (4.16)	0.66 (5.84)	0.78 (6.90)	0.98 (8.67)	1.18 (10.4)	1.27 (11.2)	1.57 (13.9)	1.96 (17.3)	2.35 (20.8)	2.55 (22.6)	3.14 (27.8)	3.82 (33.8)	4.61 (40.8)	6.37 (56.4)	7.64 (67.6)	7.84 (69.4)				
Applicable gear head	MX8G3M to MX8G180M (metal bearing)																					
	60Hz	0.32 (2.83)	0.39 (3.45)	0.55 (4.87)	0.66 (5.84)	0.81 (7.17)	0.98 (8.67)	1.08 (9.56)	1.27 (11.2)	1.57 (13.9)	1.96 (17.3)	2.06 (18.2)	2.65 (23.5)	3.14 (27.8)	3.82 (33.8)	5.29 (46.8)	6.37 (56.4)	7.84 (69.4)				
Rotational direction	Same as motor rotational direction										Reverse to motor rotational direction											

## Permissible torque at output shaft of gear head using decimal gear head

Applicable gear head		Reduction ratio		200	250	300	360	500	600	750	900	1000	1200	1500	1800
Bearing	Decimal gear head	Speed (min <sup>-1</sup> )	50Hz	7.5	6	5	4.2	3	2.5	2	1.7	1.5	1.3	1	0.8
			60Hz	9	7.2	6	5	3.6	3	2.4	2	1.8	1.5	1.2	1
MX8G□B (ball bearing) MX8G□M (metal bearing)	MX8G10XB	Permissible torque	N·m (lb-in)	7.84 (69.4)	7.84 (69.4)	7.84 (69.4)	7.84 (69.4)	7.84 (69.4)	7.84 (69.4)	7.84 (69.4)	7.84 (69.4)	7.84 (69.4)	7.84 (69.4)	7.84 (69.4)	7.84 (69.4)
		Rotational direction		Same as motor rotational direction				Reverse to motor rotational direction							

## Connection diagram

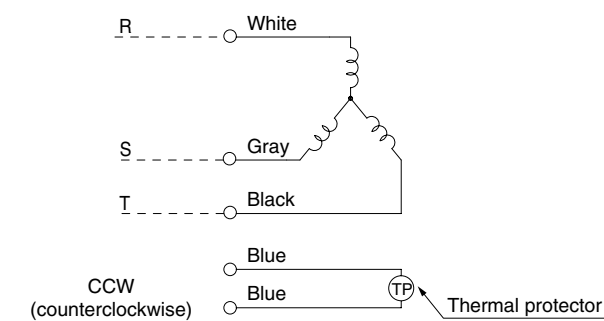

Change any two lead wires of R, S and T for CW rotation. (Refer to page A-58 for connection of thermal protector.)

## Speed-torque characteristics

M8MX25G4YG(A)

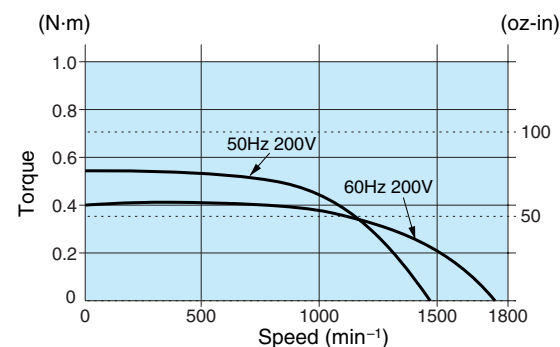

## Motor (dimensions)

M8MX25G4YG(A) 4P 25 W 200 V / 220 V / 230 V

Scale: 1/3, Unit: mm (inch)

Mass **1.5 kg** (3.31 lb)  
 Helical gear  
 Module **0.5**  
 Number of teeth **9**

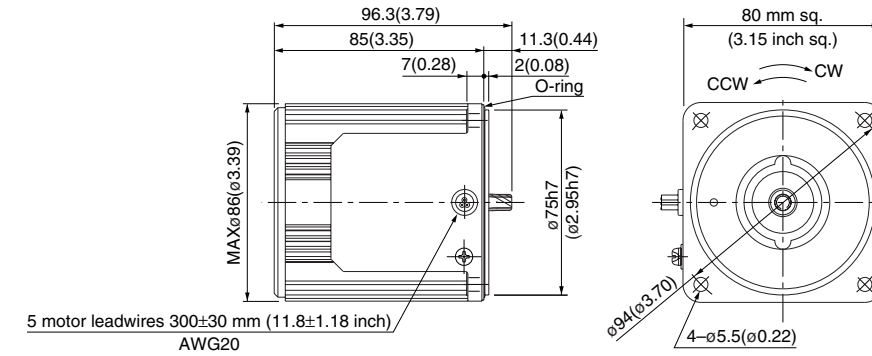

## Gear head (dimensions)

Scale: 1/3, Unit: mm (inch)

MX8G□B (ball bearing) / MX8G□M (metal bearing) Mass 0.6 kg (1.32 lb)

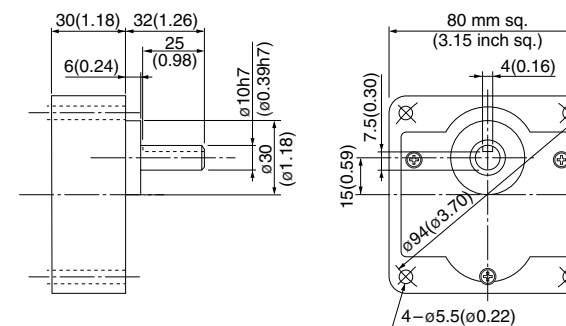

## Key and keyway (dimensions) [attachment]

MX8G□B(M)

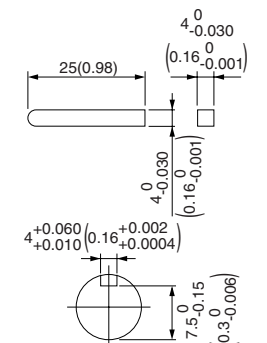

\* Please read your User's manual carefully so that you will understand the operation and safety precautions before attempting to operate the system.

(Note) Because the dimensions may be subject to change, also check the determinate dimensions if the gear head is to be used for design.

## Specifications

Size	Motor model No.	Number of pole (P)	Output (W)	Voltage (V)	Frequency (Hz)	Rating (min)	Rating				Starting current (A)	Starting torque N-m (oz-in)
							Input (W)	Current (A)	Speed (min <sup>-1</sup> )	Torque N-m (oz-in)		
90 mm sq.	M9MX40G4Y	4	40	200	50	Cont.	69	0.31	1350	0.28 (39.7)	0.90	0.72 (102)
							68	0.29	1625	0.24 (34.0)	0.82	0.51 (72.2)
				220	50	Cont.	70	0.32	1375	0.27 (38.2)	1.0	0.88 (125)
							66	0.28	1675	0.23 (32.6)	0.91	0.63 (89.2)

\* The specifications and wire connections of the round shaft motor are the same as those of the pinion shaft type. For the dimensional outline drawing, refer to page B-164.

## Permissible torque at output shaft of gear head

\* The speed shown below is a calculated value based on the synchronous rotational speed. Depending on the load, the speed is less than the indicated value by 2 to 20%.

Unit of permissible torque: upper (N·m) / lower (lb-in)

Reduction ratio		3	3.6	5	6	7.5	9	10	12.5	15	18	20	25	30	36	50	60	75	90	100	120	150	180			
Speed (min <sup>-1</sup> )	50Hz	500	416.7	300	250	200	166.7	150	120	100	83.3	75	60	50	41.7	30	25	20	16.7	15	12.5	10	8.3			
	60Hz	600	500	360	300	240	200	180	144	120	100	90	72	60	50	36	30	24	20	18	15	12	10			
Applicable gear head	MX9G3B to MX9G180B (ball bearing)	0.66 (5.84)	0.78 (6.90)	1.08 (9.56)	1.27 (11.2)	1.57 (13.9)	1.86 (16.5)	2.25 (19.9)	2.74 (24.3)	3.23 (28.6)	3.92 (34.7)	4.41 (39.0)	5.29 (46.8)	6.37 (56.4)	7.94 (70.3)	9.80 (86.7)										
	MX9G3M to MX9G180M (metal bearing)	0.55 (4.87)	0.66 (5.84)	0.90 (7.97)	1.08 (9.56)	1.27 (11.2)	1.57 (13.9)	1.76 (15.6)	2.25 (19.9)	2.74 (24.3)	3.23 (28.6)	3.53 (31.2)	4.41 (39.0)	5.29 (46.8)	6.37 (56.4)	8.82 (78.1)										
Rotational direction		Same as motor rotational direction										Reverse to motor rotational direction														

## Permissible torque at output shaft of gear head using decimal gear head

Applicable gear head		Reduction ratio		200	250	300	360	500	600	750	900	1000	1200	1500	1800
Bearing	Decimal gear head	Speed (min <sup>-1</sup> )	50Hz	7.5	6	5	4.2	3	2.5	2	1.7	1.5	1.3	1	0.8
			60Hz	9	7.2	6	5	3.6	3	2.4	2	1.8	1.5	1.2	1
MX9G□B (ball bearing) MX9G□M (metal bearing)	MX9G10XB	Permissible torque	N·m (lb-in)	9.80 (86.7)	9.80 (86.7)	9.80 (86.7)	9.80 (86.7)	9.80 (86.7)	9.80 (86.7)	9.80 (86.7)	9.80 (86.7)	9.80 (86.7)	9.80 (86.7)	9.80 (86.7)	9.80 (86.7)
			Rotational direction	Same as motor rotational direction				Reverse to motor rotational direction							

## Connection diagram

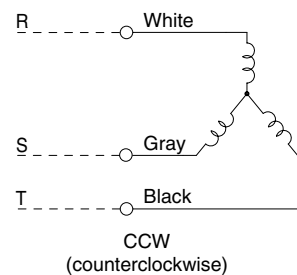

Change any two lead wires of R, S and T for CW rotation.

## Speed-torque characteristics

### M9MX40G4Y

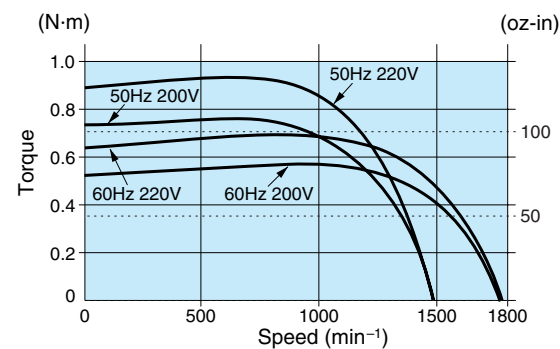

## Motor (dimensions)

Scale: 1/3, Unit: mm (inch)

M9MX40G4Y 4P 40 W 200 V / 220 V

Mass 2.4 kg 5.29 lb  
Helical gear 0.55  
Number of teeth 9

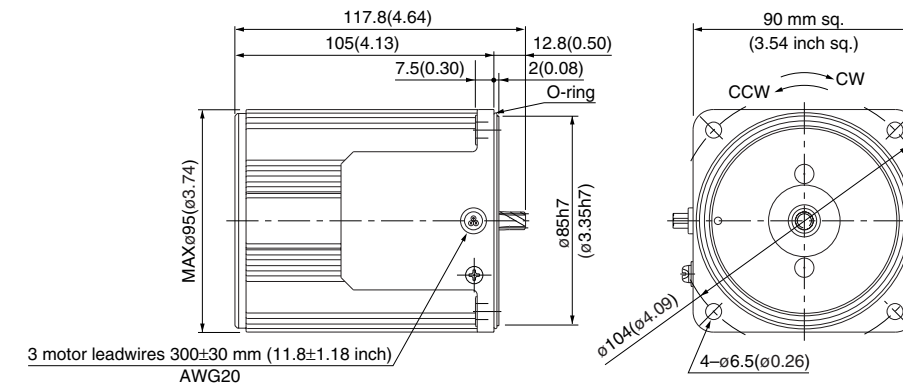

\* Diameter of applicable cable to be ø8(ø0.31) to ø12(ø0.47).

\* Please read your User's manual carefully so that you will understand the operation and safety precautions before attempting to operate the system.

## Gear head (dimensions)

Scale: 1/3, Unit: mm (inch)

MX9G□B (ball bearing) / MX9G□M (metal bearing) Mass 0.8 kg (1.76 lb)

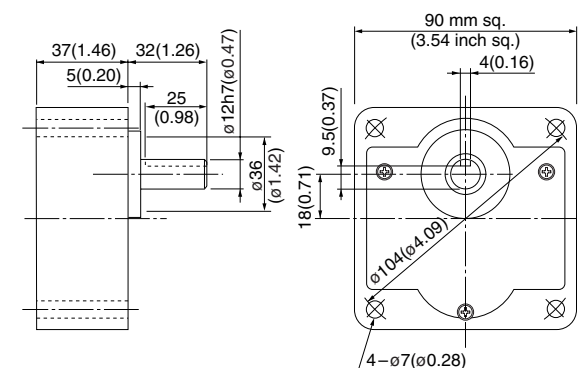

## Key and keyway (dimensions) [attachment]

MX9G□B(M)

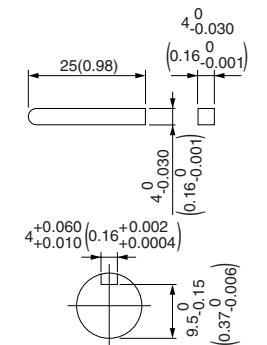

(Note) Because the dimensions may be subject to change, also check the determinate dimensions if the gear head is to be used for design.

# 3-phase motor (leadwire)

US CE 90 mm (3.54 inch) sq. 40 W

## Specifications

Size	Motor model No.	Number of pole (P)	Output (W)	Voltage (V)	Frequency (Hz)	Rating (min)	Rating				Starting current (A)	Starting torque N-m (oz-in)	
							Input (W)	Current (A)	Speed (min <sup>-1</sup> )	Torque N-m (oz-in)			
90 mm sq.	M9MX40G4YG M9MX40G4YGA	4	40	200	50	Cont.	69	0.31	1350	0.28 (39.7)	0.90	0.72 (102)	
					60		68	0.29	1625	0.24 (34.0)	0.82	0.51 (72.2)	
					220		60	66	0.28	1675	0.23 (32.6)	0.91	0.63 (89.2)
					230		60	66	0.29	1675	0.23 (32.6)	0.96	0.69 (97.7)

• The specifications and wire connections of the round shaft motor are the same as those of the pinion shaft type. For the dimensional outline drawing, refer to page B-164.  
 • The models with a motor model number to which "A" is suffixed are not sold or available in Japan.

## Permissible torque at output shaft of gear head

\* The speed shown below is a calculated value based on the synchronous rotational speed. Depending on the load, the speed is less than the indicated value by 2 to 20%.

Unit of permissible torque: upper (N·m) / lower (lb-in)

Reduction ratio	3	3.6	5	6	7.5	9	10	12.5	15	18	20	25	30	36	50	60	75	90	100	120	150	180					
Speed (min <sup>-1</sup> )	50Hz	500	416.7	300	250	200	166.7	150	120	100	83.3	75	60	50	41.7	30	25	20	16.7	15	12.5	10	8.3				
	60Hz	600	500	360	300	240	200	180	144	120	100	90	72	60	50	36	30	24	20	18	15	12	10				
Applicable gear head	MX9G3B to MX9G180B (ball bearing) MX9G3M to MX9G180M (metal bearing)	50Hz	0.66 (5.84)	0.78 (6.90)	1.08 (9.56)	1.27 (11.2)	1.57 (13.9)	1.86 (16.5)	2.25 (19.9)	2.74 (24.3)	3.23 (28.6)	3.92 (34.7)	4.41 (39.0)	5.29 (46.8)	6.37 (56.4)	7.94 (70.3)	9.80 (86.7)										
		60Hz	0.55 (4.87)	0.66 (5.84)	0.90 (7.97)	1.08 (9.56)	1.27 (11.2)	1.57 (13.9)	1.76 (15.6)	2.25 (19.9)	2.74 (24.3)	3.23 (28.6)	3.53 (31.2)	4.41 (39.0)	5.29 (46.8)	6.37 (56.4)	8.82 (78.1)	9.80 (86.7)									
Rotational direction	Same as motor rotational direction											Reverse to motor rotational direction															

## Permissible torque at output shaft of gear head using decimal gear head

Applicable gear head		Reduction ratio	200	250	300	360	500	600	750	900	1000	1200	1500	1800
Bearing	Decimal gear head	Speed (min <sup>-1</sup> )	50Hz	7.5	6	5	4.2	3	2.5	2	1.7	1.5	1.3	1
		60Hz	9	7.2	6	5	3.6	3	2.4	2	1.8	1.5	1.2	1
MX9G□B (ball bearing) MX9G□M (metal bearing)	MX9G10XB	Permissible torque	N·m (lb-in)	9.80 (86.7)	9.80 (86.7)	9.80 (86.7)	9.80 (86.7)	9.80 (86.7)	9.80 (86.7)	9.80 (86.7)	9.80 (86.7)	9.80 (86.7)	9.80 (86.7)	9.80 (86.7)
		Rotational direction	Same as motor rotational direction			Reverse to motor rotational direction								

## Connection diagram

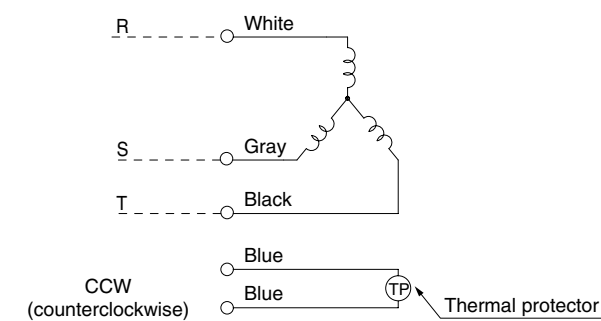

Change any two lead wires of R, S and T for CW rotation. (Refer to page A-58 for connection of thermal protector.)

## Speed-torque characteristics

### M9MX40G4YG(A)

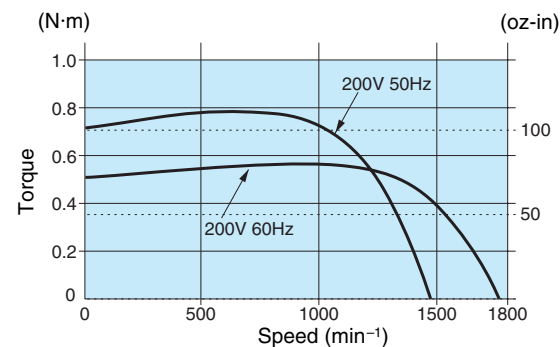

## Motor (dimensions)

M9MX40G4YG(A) 4P 40 W 200 V / 220 V / 230 V

Scale: 1/3, Unit: mm (inch)

Mass 2.4 kg (5.29 lb)  
Helical gear  
Module 0.55  
Number of teeth 9

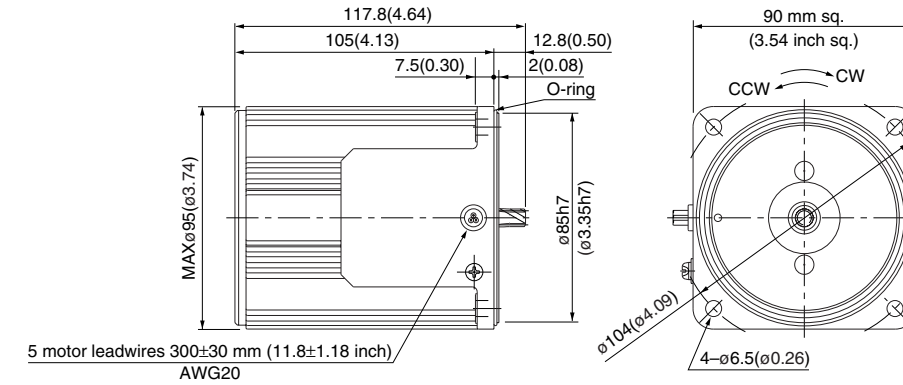

## Gear head (dimensions)

Scale: 1/3, Unit: mm (inch)

MX9G□B (ball bearing) / MX9G□M (metal bearing) Mass 0.8 kg (1.76 lb)

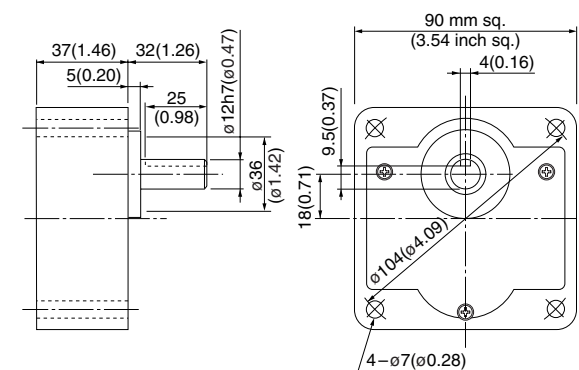

## Key and keyway (dimensions) [attachment]

MX9G□B(M)

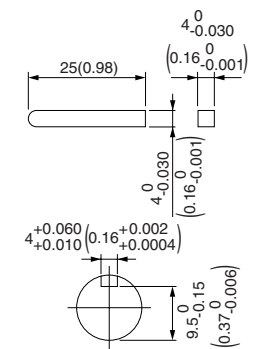

\* Please read your User's manual carefully so that you will understand the operation and safety precautions before attempting to operate the system.

(Note) Because the dimensions may be subject to change, also check the determinate dimensions if the gear head is to be used for design.

Induction motor  
Reversible motor  
3-phase motor  
Electromagnetic brake motor  
Variable speed induction motor  
Variable speed reversible motor  
Variable speed electromagnetic brake single-phase motor  
Variable speed unit motor  
C&B motor  
2-pole round shaft motor  
Gear head  
Gear head -inch (U.S.A.)

## Specifications

Size	Motor model No.	Number of pole (P)	Output (W)	Voltage (V)	Frequency (Hz)	Rating (min)	Rating				Starting current (A)	Starting torque N-m (oz-in)
							Input (W)	Current (A)	Speed (min <sup>-1</sup> )	Torque N-m (oz-in)		
90 mm sq.	M9MZ60G4Y	4	60	200	50	Cont.	101	0.45	1350	0.42 (59.5)	1.3	1.0 (142)
							96	0.41	1625	0.35 (49.6)	1.2	0.69 (97.7)
				220	60	Cont.	103	0.46	1375	0.41 (58.1)	1.5	1.2 (170)
							98	0.40	1650	0.34 (48.1)	1.3	0.87 (123)

\* The specifications and wire connections of the round shaft motor are the same as those of the pinion shaft type. For the dimensional outline drawing, refer to page B-164.

## Permissible torque at output shaft of gear head

\* The speed shown below is a calculated value based on the synchronous rotational speed. Depending on the load, the speed is less than the indicated value by 2 to 20%.

Unit of permissible torque: upper (N·m) / lower (lb-in)

Reduction ratio	Speed (min <sup>-1</sup> )																							
	3	3.6	5	6	7.5	9	10	12.5	15	18	20	25	30	36	50	60	75	90	100	120	150	180	200	
Speed (min <sup>-1</sup> )	50Hz	500	416.7	300	250	200	166.7	150	120	100	83.3	75	60	50	41.7	30	25	20	16.7	15	12.5	10	8.3	7.5
	60Hz	600	500	360	300	240	200	180	144	120	100	90	72	60	50	36	30	24	20	18	15	12	10	9
Applicable gear head	MZ9G3B to MZ9G200B (ball bearing / hinge not attached)	0.98 (8.7)	1.18 (10.4)	1.57 (13.9)	1.96 (17.3)	2.35 (20.8)	2.94 (26.0)	3.14 (27.8)	3.92 (34.7)	4.70 (41.6)	5.59 (49.5)	6.27 (55.5)	7.55 (66.8)	9.11 (80.6)	11.0 (97.4)	15.2 (135)	17.8 (158)							19.6 (173)
	MY9G3B to MY9G200B (ball bearing / hinge attached)	0.78 (6.9)	0.98 (8.7)	1.37 (12.1)	1.57 (13.9)	1.96 (17.3)	2.35 (20.8)	2.65 (23.5)	3.33 (29.5)	3.92 (34.7)	4.70 (41.6)	5.29 (46.8)	6.47 (57.3)	7.55 (66.8)	9.11 (80.6)	12.6 (112)	15.2 (135)							19.6 (173)
Rotational direction	Same as motor rotational direction						Reverse to motor rotational direction						Same as motor rotational direction											

## Permissible torque at output shaft of gear head using decimal gear head

Applicable gear head		Reduction ratio		250	300	360	500	600	750	900	1000	1200	1500	1800
Bearing	Decimal gear head	Speed (min <sup>-1</sup> )	50Hz	6	5	4.2	3	2.5	2	1.7	1.5	1.3	1	0.8
				60Hz	7.2	6	5	3.6	3	2.4	2	1.8	1.5	1.2
MZ9G□B (ball bearing / Hinge not attached)	MZ9G10XB	Permissible torque	N·m (lb-in)	19.6 (173)	19.6 (173)	19.6 (173)	19.6 (173)	19.6 (173)	19.6 (173)	19.6 (173)	19.6 (173)	19.6 (173)	19.6 (173)	19.6 (173)
MY9G□B (ball bearing / Hinge attached)				Rotational direction	Reverse to motor rotational direction	Same as motor rotational direction								

## Connection diagram

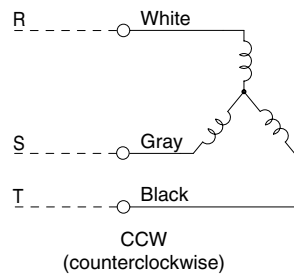

Change any two lead wires of R, S and T for CW rotation.

## Speed-torque characteristics

### M9MZ60G4Y

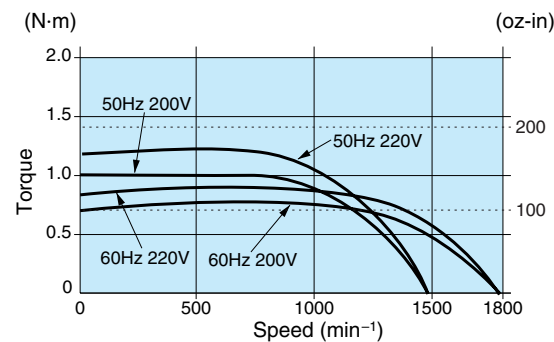

## Motor (dimensions)

Scale: 1/4, Unit: mm (inch)

M9MZ60G4Y 4P 60 W 200 V / 220 V (with fan)

Mass	Helical gear	Module	Number of teeth
2.7 kg 5.95 lb		0.6	9

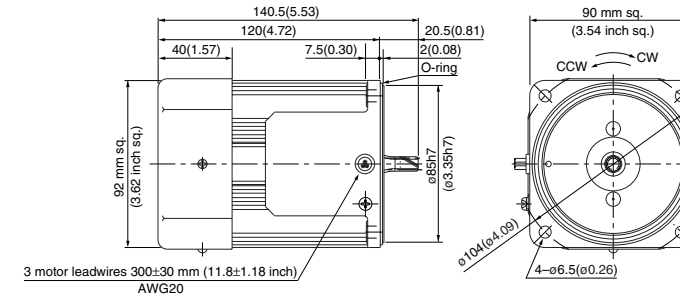

\* Diameter of applicable cable to be ø8(ø0.31) to ø12(ø0.47).

## Key and keyway (dimensions) [attachment]

Scale: 1/4, Unit: mm (inch)

## Gear head (dimensions)

MZ9G□B (ball bearing / hinge not attached)  
Mass 1.4 kg (3.09 lb)

MY9G□B (ball bearing / hinge attached)  
Mass 1.4 kg (3.09 lb)

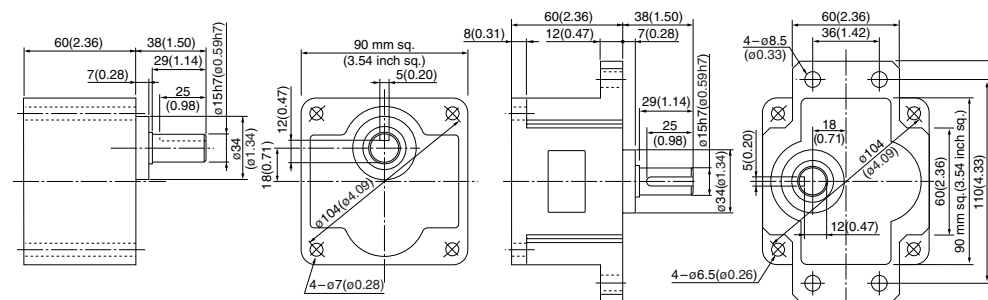

MZ9G□B  
MY9G□B

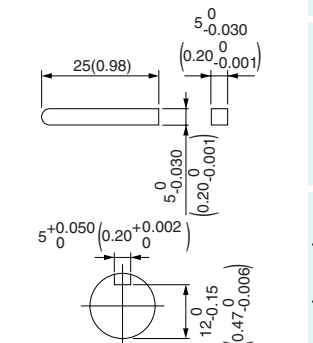

Note) MZ / MY is available for a gear head of either type.

(Note) Because the dimensions may be subject to change, also check the determinate dimensions if the gear head is to be used for design.

\* Please read your User's manual carefully so that you will understand the operation and safety precautions before attempting to operate the system.



# 3-phase motor (leadwire)

**90 mm (3.54 inch) sq. 60 W**

## Specifications

Size	Motor model No.	Number of pole (P)	Output (W)	Voltage (V)	Frequency (Hz)	Rating (min)	Rating				Starting current (A)	Starting torque N-m (oz-in)
							Input (W)	Current (A)	Speed (min <sup>-1</sup> )	Torque N-m (oz-in)		
90 mm sq.	<b>M9MZ60G4YG</b> <b>M9MZ60G4YGA</b>	4	60	200	50	Cont.	101	0.45	1350	0.42 (59.5)	1.3	1.0 (142)
							96	0.41	1625	0.35 (49.6)	1.2	0.69 (97.7)
							98	0.40	1650	0.35 (49.6)	1.3	0.87 (123)
							98	0.41	1675	0.34 (48.1)	1.4	1.0 (142)

• The specifications and wire connections of the round shaft motor are the same as those of the pinion shaft type. For the dimensional outline drawing, refer to page B-164.  
 • The models with a motor model number to which "A" is suffixed are not sold or available in Japan.

## Permissible torque at output shaft of gear head

\* The speed shown below is a calculated value based on the synchronous rotational speed. Depending on the load, the speed is less than the indicated value by 2 to 20%.

Unit of permissible torque: upper (N·m) / lower (lb·in)

Reduction ratio	3	3.6	5	6	7.5	9	10	12.5	15	18	20	25	30	36	50	60	75	90	100	120	150	180	200		
Speed (min <sup>-1</sup> )	50Hz	500	416.7	300	250	200	166.7	150	120	100	83.3	75	60	50	41.7	30	25	20	16.7	15	12.5	10	8.3	7.5	
	60Hz	600	500	360	300	240	200	180	144	120	100	90	72	60	50	36	30	24	20	18	15	12	10	9	
Applicable gear head	MZ9G3B to MZ9G200B (ball bearing / hinge not attached) MY9G3B to MY9G200B (ball bearing / hinge attached)	50Hz	0.98 (8.7)	1.18 (10.4)	1.57 (13.9)	1.96 (17.3)	2.35 (20.8)	2.94 (26.0)	3.14 (27.8)	3.92 (34.7)	4.70 (41.6)	5.59 (49.5)	6.27 (55.5)	7.55 (66.8)	9.11 (80.6)	11.0 (97.4)	15.2 (135)	17.8 (158)							19.6 (173)
		60Hz	0.78 (6.9)	0.98 (8.7)	1.37 (12.1)	1.57 (13.9)	1.96 (17.3)	2.65 (23.5)	3.33 (29.5)	3.92 (34.7)	4.70 (41.6)	5.29 (46.8)	6.47 (57.3)	7.55 (66.8)	9.11 (80.6)	12.6 (112)	15.2 (135)							19.6 (173)	
Rotational direction	Same as motor rotational direction						Reverse to motor rotational direction						Same as motor rotational direction												

## Permissible torque at output shaft of gear head using decimal gear head

Applicable gear head		Reduction ratio	250	300	360	500	600	750	900	1000	1200	1500	1800	
Bearing	Decimal gear head	Speed (min <sup>-1</sup> )	50Hz	6	5	4.2	3	2.5	2	1.7	1.5	1.3	1	0.8
		60Hz	7.2	6	5	3.6	3	2.4	2	1.8	1.5	1.2	1	
MZ9G□B (ball bearing / Hinge not attached) MY9G□B (ball bearing / Hinge attached)	MZ9G10XB	Permissible torque	N·m (lb-in)	19.6 (173)	19.6 (173)	19.6 (173)	19.6 (173)	19.6 (173)	19.6 (173)	19.6 (173)	19.6 (173)	19.6 (173)	19.6 (173)	
		Rotational direction	Reverse to motor rotational direction			Same as motor rotational direction								

## Connection diagram

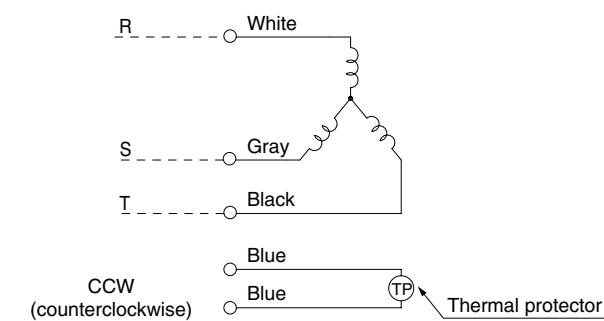

Change any two lead wires of R, S and T for CW rotation. (Refer to page A-58 for connection of thermal protector.)

## Speed-torque characteristics

M9MZ60G4YG(A)

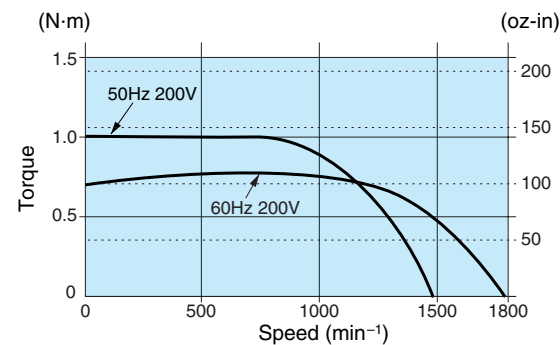

## Motor (dimensions)

M9MZ60G4YG(A) 4P 60 W 200 V / 220 V / 230 V (with fan)

Scale: 1/4, Unit: mm (inch)

Mass 2.7 kg 5.95 lb  
 Helical gear  
 Module 0.6  
 Number of teeth 9

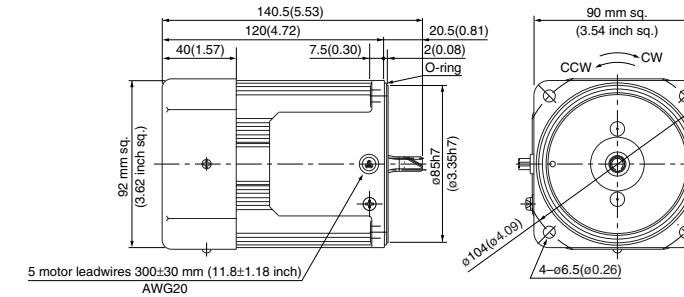

## Gear head (dimensions)

Scale: 1/4, Unit: mm (inch)

**MZ9G□B** (ball bearing / hinge not attached)  
Mass 1.4 kg (3.09 lb)

**MY9G□B** (ball bearing / hinge attached)  
Mass 1.4 kg (3.09 lb)

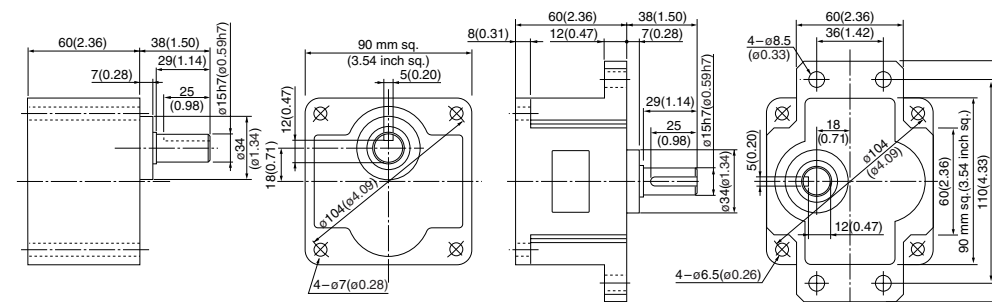

## Key and keyway (dimensions) [attachment]

**MZ9G□B**  
**MY9G□B**

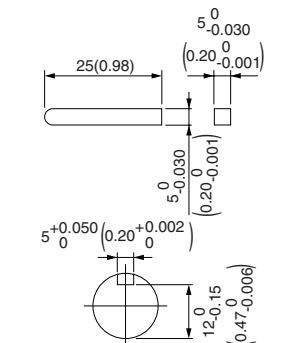

Note) MZ / MY is available for a gear head of either type.

(Note) Because the dimensions may be subject to change, also check the determinate dimensions if the gear head is to be used for design.

\* Please read your User's manual carefully so that you will understand the operation and safety precautions before attempting to operate the system.

Induction motor  
 Reversible motor  
 3-phase motor  
 Electromagnetic brake motor  
 Variable speed induction motor  
 Variable speed reversible motor  
 Variable speed electromagnetic brake single-phase motor  
 Variable speed unit motor  
 C&B motor  
 2-pole round shaft motor  
 Gear head  
 Gear head -inch (U.S.A.)

## Specifications

Size	Motor model No.	Number of pole (P)	Output (W)	Voltage (V)	Frequency (Hz)	Rating (min)	Rating				Starting current (A)	Starting torque N-m (oz-in)
							Input (W)	Current (A)	Speed (min <sup>-1</sup> )	Torque N-m (oz-in)		
90 mm sq.	M9MZ90G4Y	4	90	200	50	Cont.	141	0.62	1350	0.63 (89.2)	2.0	1.6 (227)
							137	0.56	1625	0.53 (75.1)	1.8	1.1 (156)
				220	50	Cont.	143	0.65	1400	0.62 (87.8)	2.2	2.0 (283)
							137	0.56	1650	0.52 (73.6)	2.0	1.4 (198)

\* The specifications and wire connections of the round shaft motor are the same as those of the pinion shaft type. For the dimensional outline drawing, refer to page B-164.

## Permissible torque at output shaft of gear head

\* The speed shown below is a calculated value based on the synchronous rotational speed. Depending on the load, the speed is less than the indicated value by 2 to 20%.

Unit of permissible torque: upper (N·m) / lower (lb-in)

Reduction ratio	3	3.6	5	6	7.5	9	10	12.5	15	18	20	25	30	36	50	60	75	90	100	120	150	180	200					
Speed (min <sup>-1</sup> )	50Hz	500	416.7	300	250	200	166.7	150	120	100	83.3	75	60	50	41.7	30	25	20	16.7	15	12.5	10	8.3	7.5				
	60Hz	600	500	360	300	240	200	180	144	120	100	90	72	60	50	36	30	24	20	18	15	12	10	9				
Applicable gear head	MZ9G3B to MZ9G200B (ball bearing / hinge not attached)	50Hz	1.37	1.67	2.25	2.74	3.43	4.12	4.51	5.68	6.76	8.04	9.02	10.9	13.0	15.7	19.6											19.6
		60Hz	1.18	1.37	1.86	2.25	2.84	3.43	3.72	4.70	5.68	6.76	7.55	9.21	10.9	13.0	18.3											19.6
Rotational direction	Same as motor rotational direction						Reverse to motor rotational direction						Same as motor rotational direction															

## Permissible torque at output shaft of gear head using decimal gear head

Applicable gear head		Reduction ratio	250	300	360	500	600	750	900	1000	1200	1500	1800
Bearing	Decimal gear head	Speed (min <sup>-1</sup> )	50Hz	6	5	4.2	3	2.5	2	1.7	1.5	1.3	0.8
		60Hz	7.2	6	5	3.6	3	2.4	2	1.8	1.5	1.2	1
MZ9G□B (ball bearing / hinge not attached) MY9G□B (ball bearing / hinge attached)	MZ9G10XB	Permissible torque	N·m (lb-in)	19.6 (173)	19.6 (173)	19.6 (173)	19.6 (173)	19.6 (173)	19.6 (173)	19.6 (173)	19.6 (173)	19.6 (173)	19.6 (173)
		Rotational direction	Reverse to motor rotational direction			Same as motor rotational direction							

## Motor (dimensions)

M9MZ90G4Y 4P 90 W 200 V / 220 V (with fan)

Scale: 1/4, Unit: mm (inch)

Mass	Helical gear	Module	Number of teeth
3.2 kg 7.05 lb		0.6	9

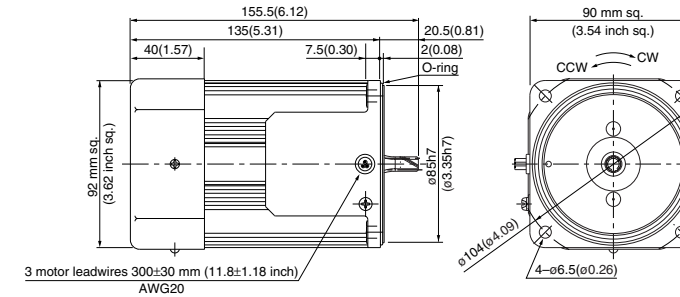

\* Diameter of applicable cable to be ø8(ø0.31) to ø12(ø0.47).

## Connection diagram

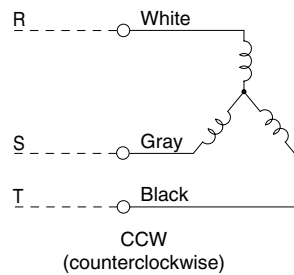

Change any two lead wires of R, S and T for CW rotation.

## Speed-torque characteristics

M9MZ90G4Y

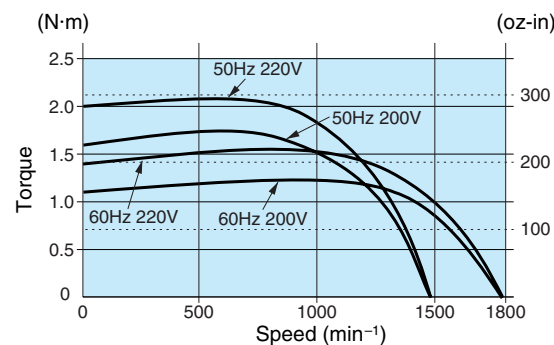

## Gear head (dimensions)

Scale: 1/4, Unit: mm (inch)

MZ9G□B (ball bearing / hinge not attached)  
Mass 1.4 kg (3.09 lb)

MY9G□B (ball bearing / hinge attached)  
Mass 1.4 kg (3.09 lb)

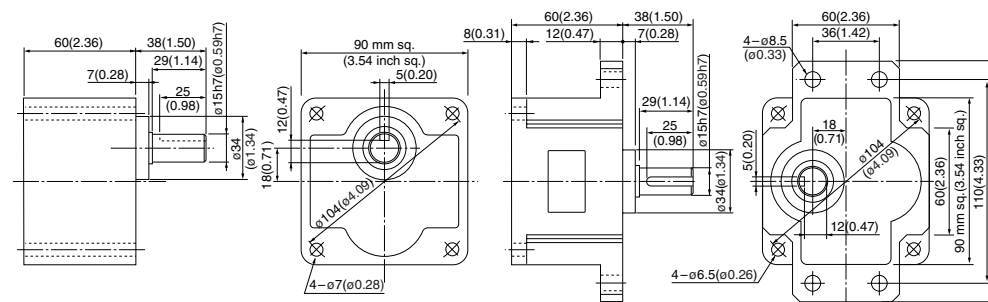

Note) MZ / MY is available for a gear head of either type.

(Note) Because the dimensions may be subject to change, also check the determinate dimensions if the gear head is to be used for design.

## Key and keyway (dimensions) [attachment]

MZ9G□B  
MY9G□B

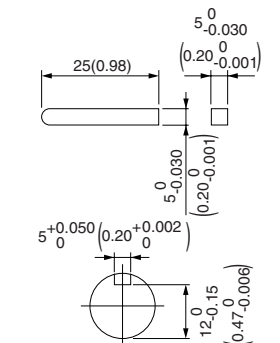

Induction motor  
Reversible motor  
3-phase motor  
Electromagnetic brake motor  
Variable speed induction motor  
Variable speed reversible motor  
Variable speed electromagnetic brake single-phase motor  
Variable speed unit motor  
C&B motor  
2-pole round shaft motor  
Gear head  
Gear head -inch (U.S.A.)

# 3-phase motor (leadwire)

**90 mm (3.54 inch) sq. 90 W**

## Specifications

Size	Motor model No.	Number of pole (P)	Output (W)	Voltage (V)	Frequency (Hz)	Rating (min)	Rating				Starting current (A)	Starting torque N-m (oz-in)
							Input (W)	Current (A)	Speed (min <sup>-1</sup> )	Torque N-m (oz-in)		
90 mm sq.	M9MZ90G4YG M9MZ90G4YGA	4	90	200	50	Cont.	142	0.62	1350	0.63 (89.2)	2.0	1.6 (227)
							138	0.56	1625	0.53 (75.1)	1.8	1.1 (156)
							137	0.56	1650	0.52 (73.6)	2.0	1.4 (198)
							137	0.58	1675	0.51 (72.2)	2.1	1.6 (227)

• The specifications and wire connections of the round shaft motor are the same as those of the pinion shaft type. For the dimensional outline drawing, refer to page B-164.  
 • The models with a motor model number to which "A" is suffixed are not sold or available in Japan.

## Permissible torque at output shaft of gear head

\* The speed shown below is a calculated value based on the synchronous rotational speed. Depending on the load, the speed is less than the indicated value by 2 to 20%.

Unit of permissible torque: upper (N·m) / lower (lb-in)

Reduction ratio	3	3.6	5	6	7.5	9	10	12.5	15	18	20	25	30	36	50	60	75	90	100	120	150	180	200			
<b>Speed (min<sup>-1</sup>)</b>	<b>50Hz</b>	500	416.7	300	250	200	166.7	150	120	100	83.3	75	60	50	41.7	30	25	20	16.7	15	12.5	10	8.3	7.5		
	<b>60Hz</b>	600	500	360	300	240	200	180	144	120	100	90	72	60	50	36	30	24	20	18	15	12	10	9		
Applicable gear head	MZ9G3B to MZ9G200B (ball bearing / hinge not attached)	1.37	1.67	2.25	2.74	3.43	4.12	4.51	5.68	6.76	8.04	9.02	10.9	13.0	15.7	19.6							19.6 (173)			
	MY9G3B to MY9G200B (ball bearing / hinge attached)	1.18	1.37	1.86	2.25	2.84	3.43	3.72	4.70	5.68	6.76	7.55	9.21	10.9	13.0	18.3							19.6 (173)			
<b>Rotational direction</b>	Same as motor rotational direction						Reverse to motor rotational direction						Same as motor rotational direction													

## Permissible torque at output shaft of gear head using decimal gear head

Applicable gear head		Reduction ratio	250	300	360	500	600	750	900	1000	1200	1500	1800	
Bearing	Decimal gear head	Speed (min <sup>-1</sup> )	50Hz	6	5	4.2	3	2.5	2	1.7	1.5	1.3	1	0.8
		60Hz	7.2	6	5	3.6	3	2.4	2	1.8	1.5	1.2	1	
MZ9G□B (ball bearing / hinge not attached)	MZ9G10XB	Permissible torque	N·m	19.6	19.6	19.6	19.6	19.6	19.6	19.6	19.6	19.6	19.6	19.6
MY9G□B (ball bearing / hinge attached)		(lb-in)	(173)	(173)	(173)	(173)	(173)	(173)	(173)	(173)	(173)	(173)	(173)	(173)
<b>Rotational direction</b>		Reverse to motor rotational direction			Same as motor rotational direction									

## Connection diagram

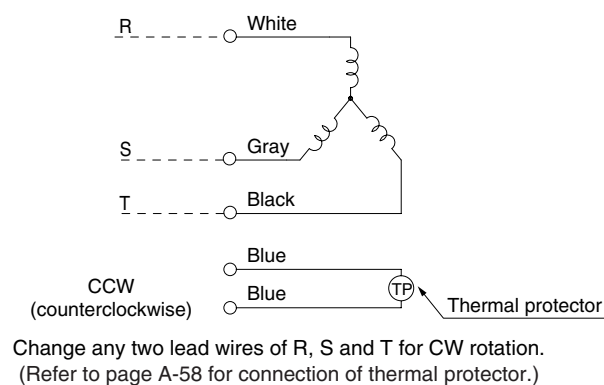

## Speed-torque characteristics

M9MZ90G4YG(A)

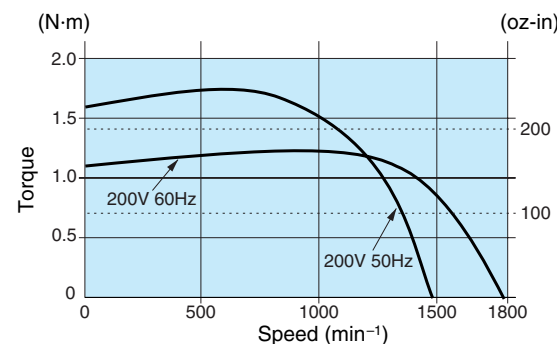

## Motor (dimensions)

M9MZ90G4YG(A) 4P 90 W 200 V / 220 V / 230 V (with fan)

Scale: 1/4, Unit: mm (inch)

Mass **3.2 kg**  
 7.05 lb  
 Helical gear  
 Module **0.6**  
 Number of teeth **9**

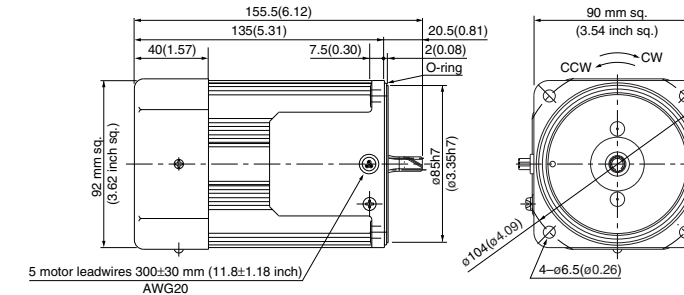

\* Please read your User's manual carefully so that you will understand the operation and safety precautions before attempting to operate the system.

## Gear head (dimensions)

Scale: 1/4, Unit: mm (inch)

MZ9G□B (ball bearing / hinge not attached)  
Mass 1.4 kg (3.09 lb)

MY9G□B (ball bearing / hinge attached)  
Mass 1.4 kg (3.09 lb)

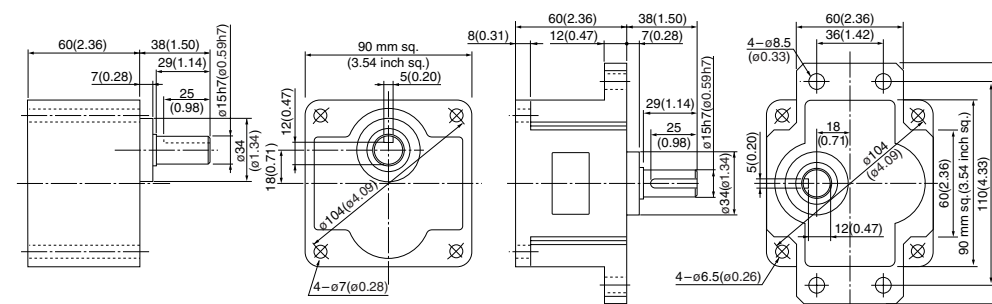

## Key and keyway (dimensions) [attachment]

MZ9G□B  
MY9G□B

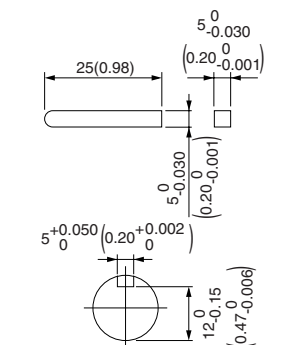

Note) MZ / MY is available for a gear head of either type.

(Note) Because the dimensions may be subject to change, also check the determinate dimensions if the gear head is to be used for design.

Induction motor  
 Reversible motor  
 3-phase motor  
 Electromagnetic brake motor  
 Variable speed induction motor  
 Variable speed reversible motor  
 Variable speed electromagnetic brake single-phase motor  
 Variable speed unit motor  
 C&B motor  
 2-pole round shaft motor  
 Gear head  
 Gear head -inch (U.S.A.)

## Specifications

Size	Motor model No.	Number of pole (P)	Output (W)	Voltage (V)	Frequency (Hz)	Rating (min)	Rating				Starting current (A)	Starting torque N-m (oz-in)
							Input (W)	Current (A)	Speed (min <sup>-1</sup> )	Torque N-m (oz-in)		
80 mm sq.	M8MX25GK4Y	4	25	200	50	Cont.	50	0.25	1350	0.18 (25.5)	0.62	0.54 (76.5)
							47	0.22	1625	0.15 (21.2)	0.58	0.40 (56.6)
				220	60	Cont.	54	0.27	1375	0.18 (25.5)	0.67	0.66 (93.5)
							49	0.23	1650	0.15 (21.2)	0.64	0.50 (70.8)

\* The specifications and wire connections of the round shaft motor are the same as those of the pinion shaft type. For the dimensional outline drawing, refer to page B-165.

## Permissible torque at output shaft of gear head

\* The speed shown below is a calculated value based on the synchronous rotational speed. Depending on the load, the speed is less than the indicated value by 2 to 20%.

Unit of permissible torque: upper (N·m) / lower (lb-in)

Reduction ratio	3	3.6	5	6	7.5	9	10	12.5	15	18	20	25	30	36	50	60	75	90	100	120	150	180			
<b>Speed (min<sup>-1</sup>)</b>	<b>50Hz</b>	500	416.7	300	250	200	166.7	150	120	100	83.3	75	60	50	41.7	30	25	20	16.7	15	12.5	10	8.3		
	<b>60Hz</b>	600	500	360	300	240	200	180	144	120	100	90	72	60	50	36	30	24	20	18	15	12	10		
Applicable gear head	MX8G3B to MX8G180B (ball bearing)	50Hz	0.39 (3.45)	0.47 (4.16)	0.66 (5.84)	0.78 (6.90)	0.98 (8.67)	1.18 (10.4)	1.27 (11.2)	1.57 (13.9)	1.96 (17.3)	2.35 (20.8)	2.55 (22.6)	3.14 (27.8)	3.82 (33.8)	4.61 (40.8)	6.37 (56.4)	7.64 (67.6)							7.84 (69.4)
	MX8G3M to MX8G180M (metal bearing)	60Hz	0.32 (2.83)	0.39 (3.45)	0.55 (4.87)	0.66 (5.84)	0.81 (7.17)	0.98 (8.67)	1.08 (9.56)	1.27 (11.2)	1.57 (13.9)	1.96 (17.3)	2.06 (18.2)	2.65 (23.5)	3.14 (27.8)	3.82 (33.8)	5.29 (46.8)	6.37 (56.4)							7.84 (69.4)
<b>Rotational direction</b>	Same as motor rotational direction											Reverse to motor rotational direction													

## Permissible torque at output shaft of gear head using decimal gear head

Applicable gear head		Reduction ratio	200	250	300	360	500	600	750	900	1000	1200	1500	1800	
Bearing	Decimal gear head	Speed (min <sup>-1</sup> )	50Hz	7.5	6	5	4.2	3	2.5	2	1.7	1.5	1.3	1	0.8
		60Hz	9	7.2	6	5	3.6	3	2.4	2	1.8	1.5	1.2	1	
MX8G□B (ball bearing) MX8G□M (metal bearing)	MX8G10XB	Permissible torque	N·m (lb-in)	7.84 (69.4)	7.84 (69.4)	7.84 (69.4)	7.84 (69.4)	7.84 (69.4)	7.84 (69.4)	7.84 (69.4)	7.84 (69.4)	7.84 (69.4)	7.84 (69.4)	7.84 (69.4)	
		Rotational direction	Same as motor rotational direction			Reverse to motor rotational direction									

## Connection diagram

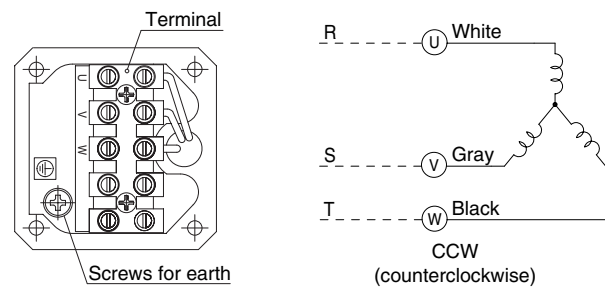

Change any two lead wires of U, V and W for CW rotation.

## Speed-torque characteristics

### M8MX25GK4Y

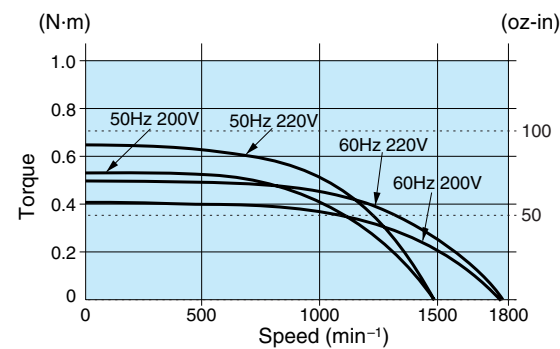

## Motor (dimensions)

M8MX25GK4Y 4P 25 W 200 V / 220 V

Scale: 1/3, Unit: mm (inch)

Mass	Helical gear	Module	Number of teeth
1.8 kg 3.97 lb	0.5	9	

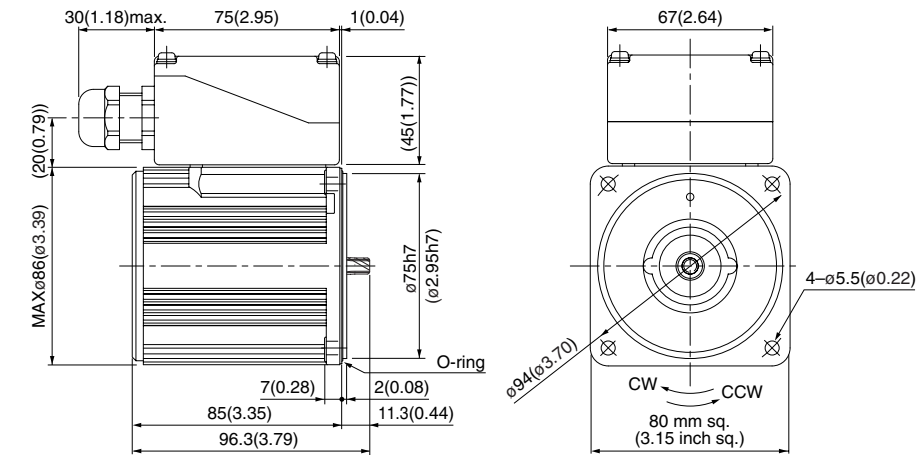

\* Diameter of applicable cable to be ø8(ø0.31) to ø12(ø0.47).

## Gear head (dimensions)

MX8G□B (ball bearing) / MX8G□M (metal bearing) Mass 0.6 kg (1.32 lb)

Scale: 1/3, Unit: mm (inch)

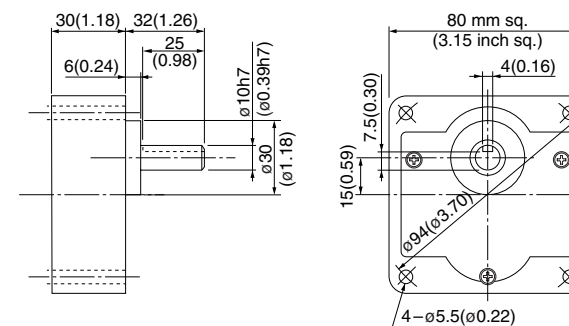

## Key and keyway (dimensions) [attachment]

MX8G□B(M)

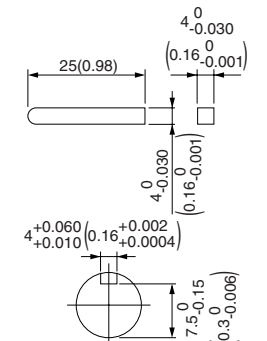

\* Please read your User's manual carefully so that you will understand the operation and safety precautions before attempting to operate the system.

(Note) Because the dimensions may be subject to change, also check the determinate dimensions if the gear head is to be used for design.

Induction motor  
Reversible motor  
3-phase motor  
Electromagnetic brake motor  
Variable speed induction motor  
Variable speed reversible motor  
Variable speed electromagnetic brake single-phase motor  
Variable speed unit motor  
C&B motor  
2-pole round shaft motor  
Gear head  
Gear head -inch (U.S.A.)

# 3-phase motor (sealed connector)

US CE 80 mm (3.15 inch) sq. 25 W

## Specifications

Size	Motor model No.	Number of pole (P)	Output (W)	Voltage (V)	Frequency (Hz)	Rating (min)	Rating				Starting current (A)	Starting torque N-m (oz-in)
							Input (W)	Current (A)	Speed (min <sup>-1</sup> )	Torque N-m (oz-in)		
80 mm sq.	M8MX25GK4YG M8MX25GK4YGA	4	25	200	50	Cont.	50	0.25	1350	0.18 (25.5)	0.62	0.54 (76.5)
					60		47	0.22	1625	0.15 (21.2)	0.58	0.40 (56.6)
				220	60	49	0.23	1650	0.14 (19.8)	0.64	0.50 (70.8)	
					60	50	0.24	1675	0.14 (19.8)	0.65	0.54 (76.5)	
	380	4	25	Cont.	50	49	0.12	1325	0.18 (25.5)	0.29	0.50 (70.8)	
					50	52	0.12	1325	0.18 (25.5)	0.32	0.56 (79.3)	

The specifications and wire connections of the round shaft motor are the same as those of the pinion shaft type. For the dimensional outline drawing, refer to page B-165.  
The models with a motor model number to which "A" is suffixed are not sold or available in Japan.

## Permissible torque at output shaft of gear head

\* The speed shown below is a calculated value based on the synchronous rotational speed. Depending on the load, the speed is less than the indicated value by 2 to 20%.

Unit of permissible torque: upper (N·m) / lower (lb-in)

Reduction ratio	Unit of permissible torque: upper (N·m) / lower (lb-in)																						
	3	3.6	5	6	7.5	9	10	12.5	15	18	20	25	30	36	50	60	75	90	100	120	150	180	
Speed (min <sup>-1</sup> )	50Hz	500	416.7	300	250	200	166.7	150	120	100	83.3	75	60	50	41.7	30	25	20	16.7	15	12.5	10	8.3
	60Hz	600	500	360	300	240	200	180	144	120	100	90	72	60	50	36	30	24	20	18	15	12	10
Applicable gear head	MX8G3B to MX8G180B (ball bearing)	0.39 (3.45)	0.47 (4.16)	0.66 (5.84)	0.78 (6.90)	0.98 (8.67)	1.18 (10.4)	1.27 (11.2)	1.57 (13.9)	1.96 (17.3)	2.35 (20.8)	2.55 (22.6)	3.14 (27.8)	4.61 (40.8)	6.37 (56.4)	7.64 (67.6)							7.84 (69.4)
	MX8G3M to MX8G180M (metal bearing)	0.32 (2.83)	0.39 (3.45)	0.55 (4.87)	0.66 (5.84)	0.81 (7.17)	0.98 (8.67)	1.08 (9.56)	1.27 (11.2)	1.57 (13.9)	1.96 (17.3)	2.06 (18.2)	2.65 (23.5)	3.14 (27.8)	3.82 (33.8)	5.29 (46.8)	6.37 (56.4)						
Rotational direction	Same as motor rotational direction											Reverse to motor rotational direction											

## Permissible torque at output shaft of gear head using decimal gear head

Applicable gear head		Reduction ratio		200	250	300	360	500	600	750	900	1000	1200	1500	1800
Bearing	Decimal gear head	Speed (min <sup>-1</sup> )	50Hz	7.5	6	5	4.2	3	2.5	2	1.7	1.5	1.3	1	0.8
				60Hz	9	7.2	6	5	3.6	3	2.4	2	1.8	1.5	1.2
MX8G□B (ball bearing) MX8G□M (metal bearing)	MX8G10XB	Permissible torque	N·m (lb-in)	7.84 (69.4)	7.84 (69.4)	7.84 (69.4)	7.84 (69.4)	7.84 (69.4)	7.84 (69.4)	7.84 (69.4)	7.84 (69.4)	7.84 (69.4)	7.84 (69.4)	7.84 (69.4)	7.84 (69.4)
		Rotational direction		Same as motor rotational direction	Reverse to motor rotational direction										

## Connection diagram

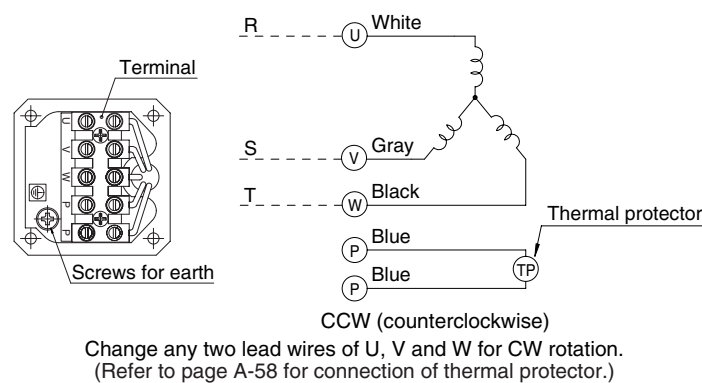

## Speed-torque characteristics

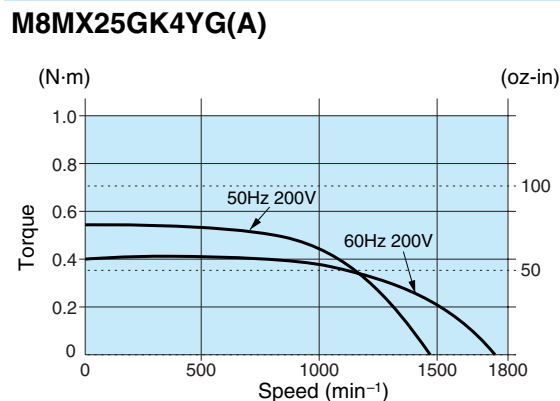

## Motor (dimensions)

Scale: 1/3, Unit: mm (inch)

M8MX25GK4YG(A) 4P 25 W 200 V / 220 V / 230 V  
M8MX25GK4CG(A) 4P 25 W 380 V / 400 V

Mass 1.8 kg 3.97 lb  
Helical gear  
Module 0.5  
Number of teeth 9

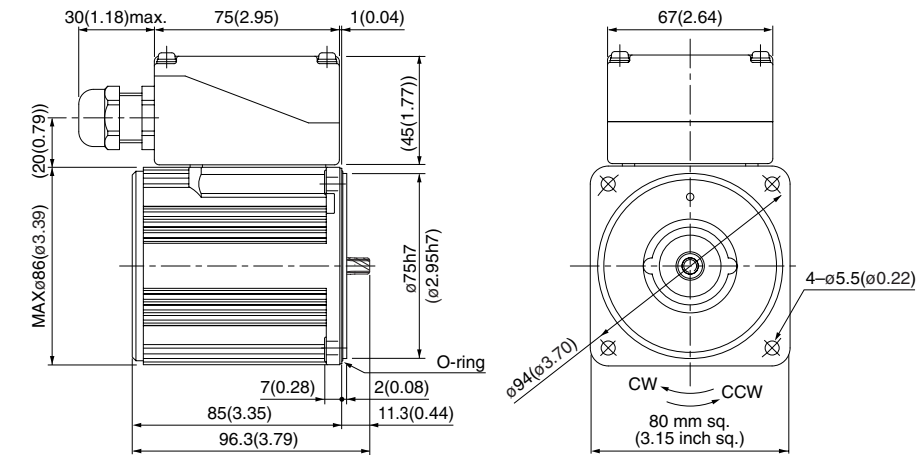

\* Diameter of applicable cable to be ø8(ø0.31) to ø12(ø0.47).

## Gear head (dimensions)

Scale: 1/3, Unit: mm (inch)

MX8G□B (ball bearing) / MX8G□M (metal bearing) Mass 0.6 kg (1.32 lb)

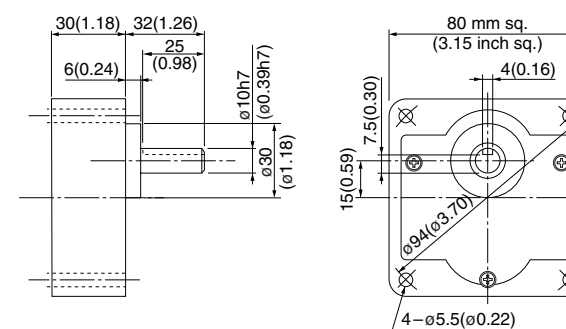

## Key and keyway (dimensions) [attachment]

MX8G□B(M)

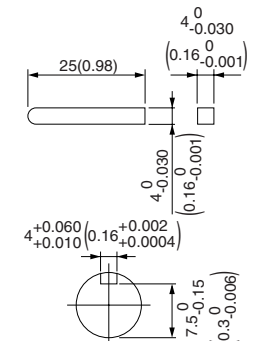

\* Please read your User's manual carefully so that you will understand the operation and safety precautions before attempting to operate the system.

(Note) Because the dimensions may be subject to change, also check the determinate dimensions if the gear head is to be used for design.

Induction motor  
Reversible motor  
3-phase motor  
Electromagnetic brake motor  
Variable speed induction motor  
Variable speed reversible motor  
Variable speed electromagnetic brake single-phase motor  
Variable speed unit motor  
C&B motor  
2-pole round shaft motor  
Gear head  
Gear head -inch (U.S.A.)

# 3-phase motor (sealed connector)

90 mm (3.54 inch) sq. 40 W

## Specifications

Size	Motor model No.	Number of pole (P)	Output (W)	Voltage (V)	Frequency (Hz)	Rating (min)	Rating				Starting current (A)	Starting torque N-m (oz-in)
							Input (W)	Current (A)	Speed (min <sup>-1</sup> )	Torque N-m (oz-in)		
90 mm sq.	M9MX40GK4Y	4	40	200	50	Cont.	69	0.31	1350	0.28 (39.7)	0.90	0.72 (102)
							68	0.29	1625	0.24 (34.0)	0.82	0.51 (72.2)
				220	60	Cont.	70	0.32	1375	0.27 (38.2)	1.0	0.88 (125)
							66	0.28	1675	0.23 (32.6)	0.91	0.63 (89.2)

\* The specifications and wire connections of the round shaft motor are the same as those of the pinion shaft type. For the dimensional outline drawing, refer to page B-165.

## Permissible torque at output shaft of gear head

\* The speed shown below is a calculated value based on the synchronous rotational speed. Depending on the load, the speed is less than the indicated value by 2 to 20%.

Unit of permissible torque: upper (N·m) / lower (lb-in)

Reduction ratio	3	3.6	5	6	7.5	9	10	12.5	15	18	20	25	30	36	50	60	75	90	100	120	150	180		
Speed (min <sup>-1</sup> )	50Hz	500	416.7	300	250	200	166.7	150	120	100	83.3	75	60	50	41.7	30	25	20	16.7	15	12.5	10	8.3	
	60Hz	600	500	360	300	240	200	180	144	120	100	90	72	60	50	36	30	24	20	18	15	12	10	
Applicable gear head	MX9G3B to MX9G180B (ball bearing)	50Hz	0.66 (5.84)	0.78 (6.90)	1.08 (9.56)	1.27 (11.2)	1.57 (13.9)	1.86 (16.5)	2.25 (19.9)	2.74 (24.3)	3.23 (28.6)	3.92 (34.7)	4.41 (39.0)	5.29 (46.8)	6.37 (56.4)	7.94 (70.3)	9.80 (86.7)							9.80 (86.7)
	MX9G3M to MX9G180M (metal bearing)	60Hz	0.55 (4.87)	0.66 (5.84)	0.90 (7.97)	1.08 (9.56)	1.27 (11.2)	1.57 (13.9)	1.76 (15.6)	2.25 (19.9)	2.74 (24.3)	3.23 (28.6)	3.53 (31.2)	4.41 (39.0)	5.29 (46.8)	6.37 (56.4)	8.82 (78.1)							9.80 (86.7)
Rotational direction		Same as motor rotational direction											Reverse to motor rotational direction											

## Permissible torque at output shaft of gear head using decimal gear head

Applicable gear head		Reduction ratio	200	250	300	360	500	600	750	900	1000	1200	1500	1800
Bearing	Decimal gear head	Speed (min <sup>-1</sup> )	50Hz	7.5	6	5	4.2	3	2.5	2	1.7	1.5	1.3	1
		60Hz	9	7.2	6	5	3.6	3	2.4	2	1.8	1.5	1.2	1
MX9G□B (ball bearing) MX9G□M (metal bearing)	MX9G10XB	Permissible torque	N·m (lb-in)	9.80 (86.7)	9.80 (86.7)	9.80 (86.7)	9.80 (86.7)	9.80 (86.7)	9.80 (86.7)	9.80 (86.7)	9.80 (86.7)	9.80 (86.7)	9.80 (86.7)	9.80 (86.7)
		Rotational direction		Same as motor rotational direction					Reverse to motor rotational direction					

## Connection diagram

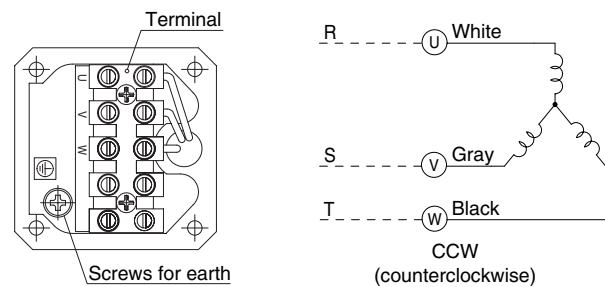

Change any two lead wires of U, V and W for CW rotation.

## Speed-torque characteristics

M9MX40GK4Y

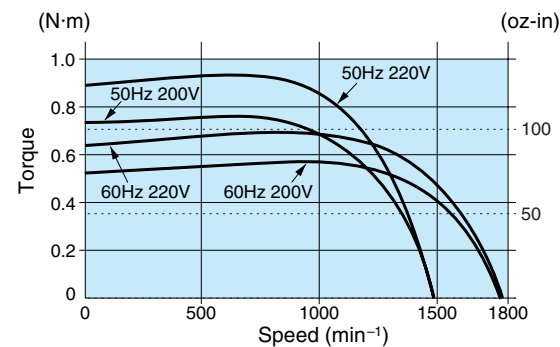

## Motor (dimensions)

M9MX40GK4Y 4P 40 W 200 V / 220 V

Scale: 1/3, Unit: mm (inch)

Mass 2.8 kg 6.17 lb  
Helical gear 0.55  
Number of teeth 9

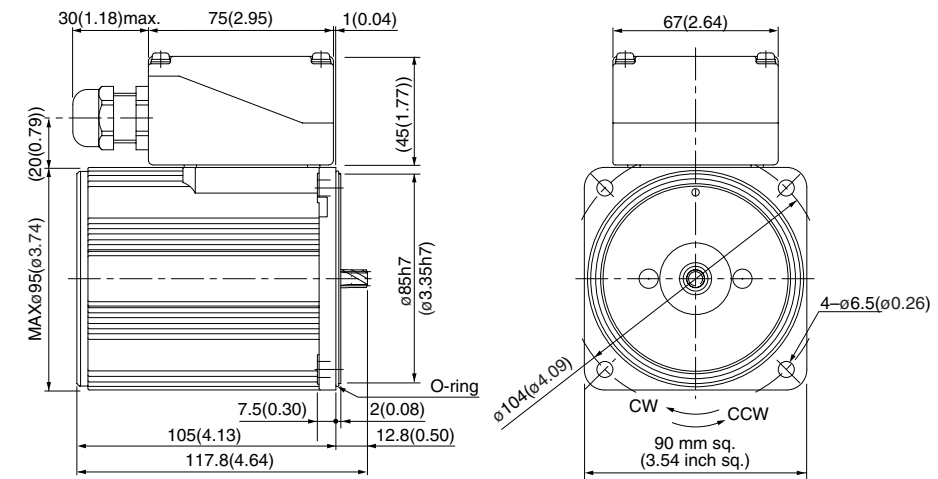

\* Diameter of applicable cable to be φ8(φ0.31) to φ12(φ0.47).

## Gear head (dimensions)

MX9G□B (ball bearing) / MX9G□M (metal bearing) Mass 0.8 kg (1.76 lb)

Scale: 1/3, Unit: mm (inch)

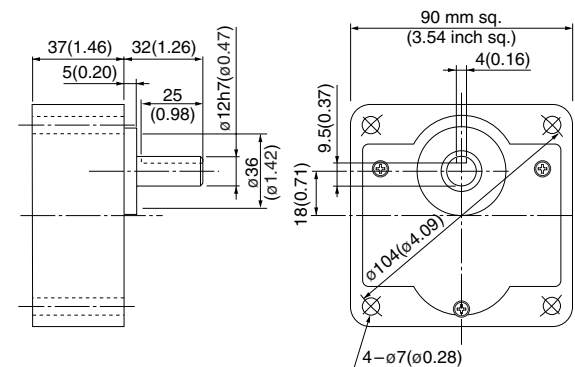

## Key and keyway (dimensions) [attachment]

MX9G□B(M)

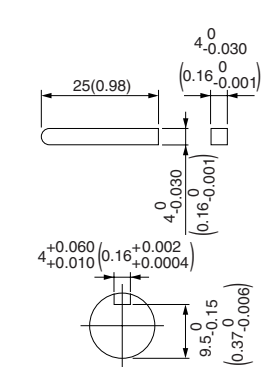

\* Please read your User's manual carefully so that you will understand the operation and safety precautions before attempting to operate the system.

(Note) Because the dimensions may be subject to change, also check the determinate dimensions if the gear head is to be used for design.

# 3-phase motor (sealed connector)

US CE 90 mm (3.54 inch) sq. 40 W

## Specifications

Size	Motor model No.	Number of pole (P)	Output (W)	Voltage (V)	Frequency (Hz)	Rating (min)	Rating				Starting current (A)	Starting torque N-m (oz-in)
							Input (W)	Current (A)	Speed (min <sup>-1</sup> )	Torque N-m (oz-in)		
90 mm sq.	M9MX40GK4YG M9MX40GK4YGA	4	40	200	50	Cont.	69	0.31	1350	0.28 (39.7)	0.90	0.72 (102)
					60		68	0.29	1625	0.24 (34.0)	0.82	0.51 (72.2)
				230	60	66	0.28	1675	0.23 (32.6)	0.91	0.63 (89.2)	
					60	66	0.29	1675	0.23 (32.6)	0.96	0.69 (97.7)	
	M9MX40GK4CG M9MX40GK4CGA	4	40	380	50	Cont.	68	0.15	1325	0.29 (41.1)	0.44	0.64 (90.6)
				400	50		66	0.15	1350	0.28 (39.7)	0.47	0.74 (105)

The specifications and wire connections of the round shaft motor are the same as those of the pinion shaft type. For the dimensional outline drawing, refer to page B-165.  
The models with a motor model number to which "A" is suffixed are not sold or available in Japan.

## Permissible torque at output shaft of gear head

The speed shown below is a calculated value based on the synchronous rotational speed. Depending on the load, the speed is less than the indicated value by 2 to 20%.

Unit of permissible torque: upper (N·m) / lower (lb-in)

Reduction ratio	Speed (min <sup>-1</sup> )																						
	3	3.6	5	6	7.5	9	10	12.5	15	18	20	25	30	36	50	60	75	90	100	120	150	180	
50Hz	500	416.7	300	250	200	166.7	150	120	100	83.3	75	60	50	41.7	30	25	20	16.7	15	12.5	10	8.3	
60Hz	600	500	360	300	240	200	180	144	120	100	90	72	60	50	36	30	24	20	18	15	12	10	
Applicable gear head	MX9G3B to MX9G180B (ball bearing)	50Hz	0.66 (5.84)	0.78 (6.90)	1.08 (9.56)	1.27 (11.2)	1.57 (13.9)	1.86 (16.5)	2.25 (19.9)	2.74 (24.3)	3.23 (28.6)	3.92 (34.7)	4.41 (39.0)	5.29 (46.8)	6.37 (56.4)	7.94 (70.3)	9.80 (86.7)						9.80 (86.7)
		60Hz	0.55 (4.87)	0.66 (5.84)	0.90 (7.97)	1.08 (9.56)	1.27 (11.2)	1.57 (13.9)	1.76 (15.6)	2.25 (19.9)	2.74 (24.3)	3.23 (28.6)	3.53 (31.2)	4.41 (39.0)	5.29 (46.8)	6.37 (56.4)	8.82 (78.1)						9.80 (86.7)
Rotational direction	Same as motor rotational direction											Reverse to motor rotational direction											

## Permissible torque at output shaft of gear head using decimal gear head

Applicable gear head		Reduction ratio	Speed (min <sup>-1</sup> )														
Bearing	Decimal gear head		200	250	300	360	500	600	750	900	1000	1200	1500	1800			
		MX9G□B (ball bearing) MX9G□M (metal bearing)	MX9G10XB	50Hz	7.5	6	5	4.2	3	2.5	2	1.7	1.5	1.3	1	0.8	
60Hz	9			7.2	6	5	3.6	3	2.4	2	1.8	1.5	1.2	1			
		Permissible torque	N·m (lb-in)	9.80 (86.7)	9.80 (86.7)	9.80 (86.7)	9.80 (86.7)	9.80 (86.7)	9.80 (86.7)	9.80 (86.7)	9.80 (86.7)	9.80 (86.7)	9.80 (86.7)	9.80 (86.7)			
		Rotational direction	Same as motor rotational direction			Reverse to motor rotational direction											

## Connection diagram

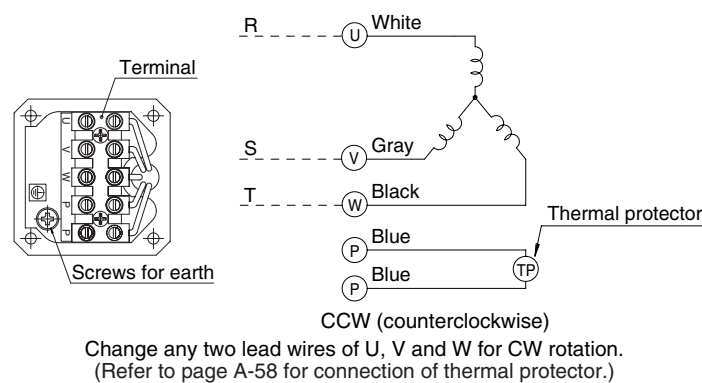

## Speed-torque characteristics

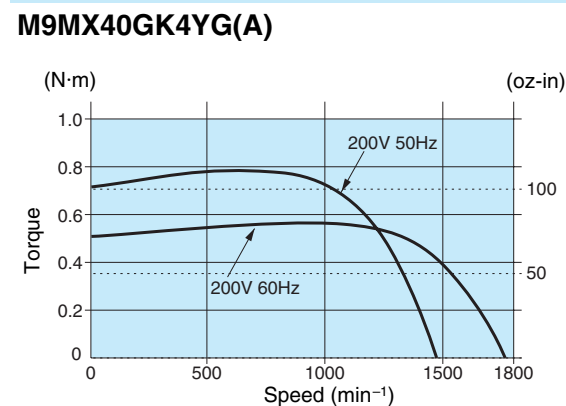

## Motor (dimensions)

Scale: 1/3, Unit: mm (inch)

M9MX40GK4YG(A) 4P 40 W 200 V / 220 V / 230 V  
M9MX40GK4CG(A) 4P 40 W 380 V / 400 V

Mass 2.8 kg 6.17 lb  
Helical gear 0.55  
Number of teeth 9

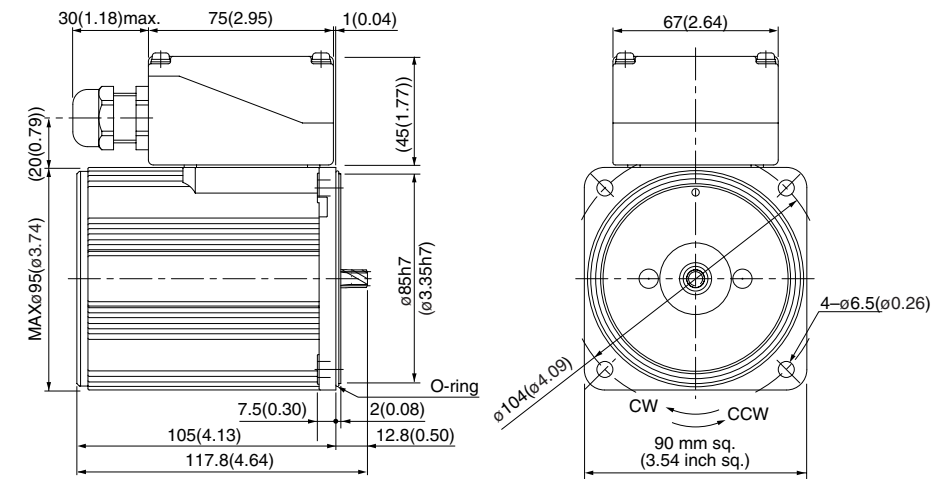

\* Diameter of applicable cable to be ø8(ø0.31) to ø12(ø0.47).

Please read your User's manual carefully so that you will understand the operation and safety precautions before attempting to operate the system.

## Gear head (dimensions)

Scale: 1/3, Unit: mm (inch)

MX9G□B (ball bearing) / MX9G□M (metal bearing) Mass 0.8 kg (1.76 lb)

## Key and keyway (dimensions) [attachment]

MX9G□B(M)

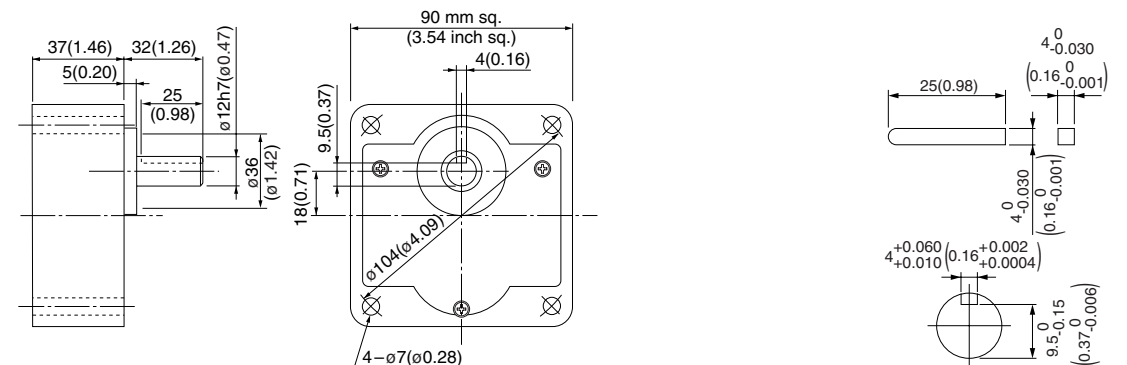

(Note) Because the dimensions may be subject to change, also check the determinate dimensions if the gear head is to be used for design.

Induction motor  
Reversible motor  
3-phase motor  
Electromagnetic brake motor  
Variable speed induction motor  
Variable speed reversible motor  
Variable speed electromagnetic brake single-phase motor  
Variable speed unit motor  
C&B motor  
2-pole round shaft motor  
Gear head  
Gear head -inch (U.S.A.)

# 3-phase motor (sealed connector)

90 mm (3.54 inch) sq. 60 W

## Specifications

Size	Motor model No.	Number of pole (P)	Output (W)	Voltage (V)	Frequency (Hz)	Rating (min)	Rating				Starting current (A)	Starting torque N-m (oz-in)
							Input (W)	Current (A)	Speed (min <sup>-1</sup> )	Torque N-m (oz-in)		
90 mm sq.	M9MZ60GK4Y	4	60	200	50	Cont.	101	0.45	1350	0.42 (59.5)	1.3	1.0 (142)
							96	0.41	1625	0.35 (49.6)	1.2	0.69 (97.7)
				220	50	Cont.	103	0.46	1375	0.41 (58.1)	1.5	1.2 (170)
							98	0.40	1650	0.34 (48.1)	1.3	0.87 (123)

\* The specifications and wire connections of the round shaft motor are the same as those of the pinion shaft type. For the dimensional outline drawing, refer to page B-165.

## Permissible torque at output shaft of gear head

\* The speed shown below is a calculated value based on the synchronous rotational speed. Depending on the load, the speed is less than the indicated value by 2 to 20%.

Unit of permissible torque: upper (N·m) / lower (lb-in)

Reduction ratio	3	3.6	5	6	7.5	9	10	12.5	15	18	20	25	30	36	50	60	75	90	100	120	150	180	200		
Speed (min <sup>-1</sup> )	50Hz	500	416.7	300	250	200	166.7	150	120	100	83.3	75	60	50	41.7	30	25	20	16.7	15	12.5	10	8.3	7.5	
	60Hz	600	500	360	300	240	200	180	144	120	100	90	72	60	50	36	30	24	20	18	15	12	10	9	
Applicable gear head	MZ9G3B to MZ9G200B (ball bearing / hinge not attached) MY9G3B to MY9G200B (ball bearing / hinge attached)	50Hz	0.98 (8.7)	1.18 (10.4)	1.57 (13.9)	1.96 (17.3)	2.35 (20.8)	2.94 (26.0)	3.14 (27.8)	3.92 (34.7)	4.70 (41.6)	5.59 (49.5)	6.27 (55.5)	7.55 (66.8)	9.11 (80.6)	11.0 (97.4)	15.2 (135)	17.8 (158)							19.6 (173)
		60Hz	0.78 (6.9)	0.98 (8.7)	1.37 (12.1)	1.57 (13.9)	1.96 (17.3)	2.65 (23.5)	3.33 (29.5)	3.92 (34.7)	4.70 (41.6)	5.29 (46.8)	6.47 (57.3)	7.55 (66.8)	9.11 (80.6)	12.6 (112)	15.2 (135)							19.6 (173)	
Rotational direction	Same as motor rotational direction						Reverse to motor rotational direction						Same as motor rotational direction												

## Permissible torque at output shaft of gear head using decimal gear head

Applicable gear head		Reduction ratio	250	300	360	500	600	750	900	1000	1200	1500	1800
Bearing	Decimal gear head	Speed (min <sup>-1</sup> )	50Hz	6	5	4.2	3	2.5	2	1.7	1.5	1.3	0.8
		60Hz	7.2	6	5	3.6	3	2.4	2	1.8	1.5	1.2	1
MZ9G□B (ball bearing / Hinge not attached) MY9G□B (ball bearing / Hinge attached)	MZ9G10XB	Permissible torque	N·m (lb-in)	19.6 (173)	19.6 (173)	19.6 (173)	19.6 (173)	19.6 (173)	19.6 (173)	19.6 (173)	19.6 (173)	19.6 (173)	19.6 (173)
		Rotational direction	Reverse to motor rotational direction			Same as motor rotational direction							

## Connection diagram

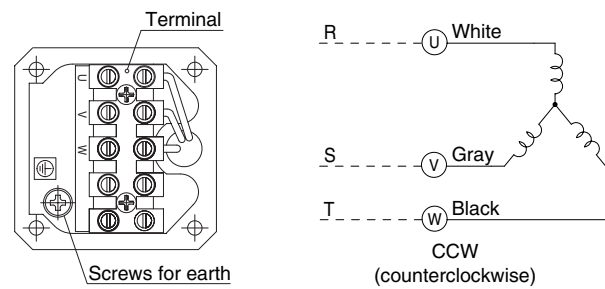

Change any two lead wires of U, V and W for CW rotation.

## Speed-torque characteristics

M9MZ60GK4Y

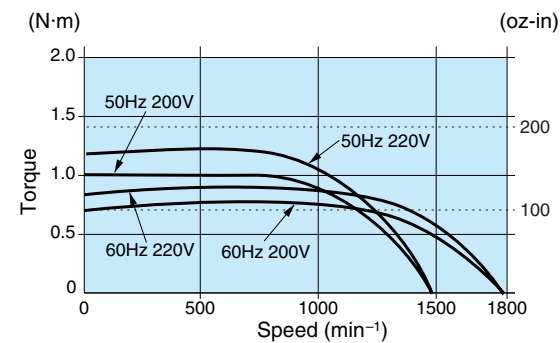

\* Please read your User's manual carefully so that you will understand the operation and safety precautions before attempting to operate the system.

## Motor (dimensions)

M9MZ60GK4Y 4P 60 W 200 V / 220 V (with fan)

Scale: 1/4, Unit: mm (inch)

Mass	Helical gear	Module	Number of teeth
3.0 kg 6.61 lb		0.6	9

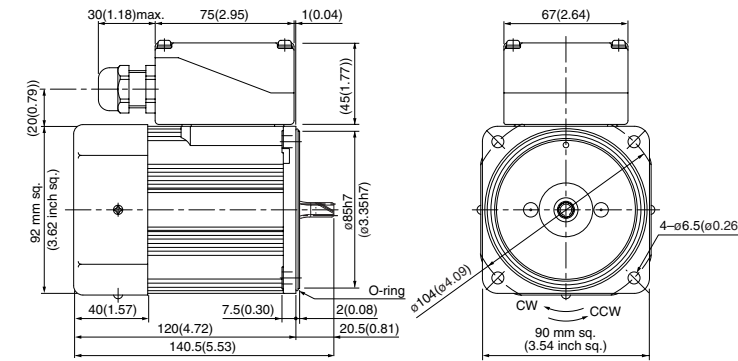

\* Diameter of applicable cable to be ø8(ø0.31) to ø12(ø0.47).

## Gear head (dimensions)

Scale: 1/4, Unit: mm (inch)

MZ9G□B (ball bearing / hinge not attached)  
Mass 1.4 kg (3.09 lb)

MY9G□B (ball bearing / hinge attached)  
Mass 1.4 kg (3.09 lb)

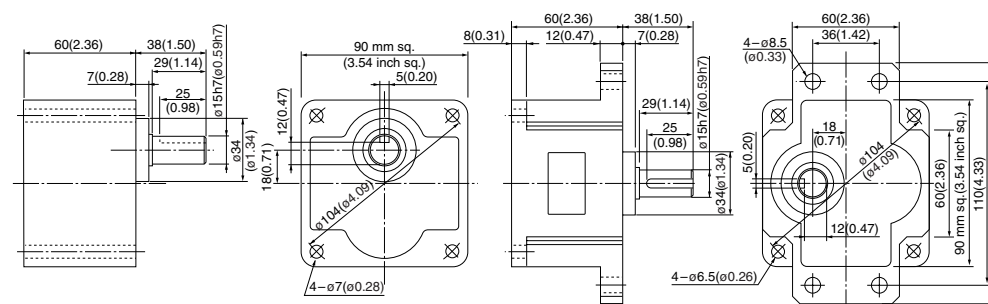

## Key and keyway (dimensions) [attachment]

MZ9G□B  
MY9G□B

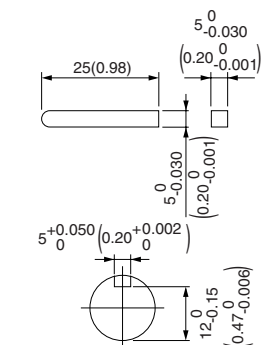

Note) MZ / MY is available for a gear head of either type.

(Note) Because the dimensions may be subject to change, also check the determinate dimensions if the gear head is to be used for design.



# 3-phase motor (sealed connector)

**90 mm (3.54 inch) sq. 60 W**

## Specifications

Size	Motor model No.	Number of pole (P)	Output (W)	Voltage (V)	Frequency (Hz)	Rating (min)	Rating				Starting current (A)	Starting torque N-m (oz-in)
							Input (W)	Current (A)	Speed (min <sup>-1</sup> )	Torque N-m (oz-in)		
90 mm sq.	M9MZ60GK4YG M9MZ60GK4YGA	4	60	200	50	Cont.	101	0.45	1350	0.42 (59.5)	1.3	1.0 (142)
							96	0.41	1625	0.35 (49.6)	1.2	0.69 (97.7)
				220	60		98	0.40	1650	0.35 (49.6)	1.3	0.87 (123)
				230	60		98	0.41	1675	0.34 (48.1)	1.4	1.0 (142)
	M9MZ60GK4CG M9MZ60GK4CGA	4	60	380	50	Cont.	103	0.22	1325	0.43 (60.9)	0.62	0.88 (125)
				400	50		103	0.22	1325	0.43 (60.9)	0.65	1.0 (142)

• The specifications and wire connections of the round shaft motor are the same as those of the pinion shaft type. For the dimensional outline drawing, refer to page B-165.  
 • The models with a motor model number to which "A" is suffixed are not sold or available in Japan.

## Permissible torque at output shaft of gear head

\* The speed shown below is a calculated value based on the synchronous rotational speed. Depending on the load, the speed is less than the indicated value by 2 to 20%.

Unit of permissible torque: upper (N·m) / lower (lb-in)

Reduction ratio	Speed (min <sup>-1</sup> )																							
	3	3.6	5	6	7.5	9	10	12.5	15	18	20	25	30	36	50	60	75	90	100	120	150	180	200	
50Hz	500	416.7	300	250	200	166.7	150	120	100	83.3	75	60	50	41.7	30	25	20	16.7	15	12.5	10	8.3	7.5	
60Hz	600	500	360	300	240	200	180	144	120	100	90	72	60	50	36	30	24	20	18	15	12	10	9	
Applicable gear head MZ9G3B to MZ9G200B (ball bearing / hinge not attached) MY9G3B to MY9G200B (ball bearing / hinge attached)	50Hz	0.98 (8.7)	1.18 (10.4)	1.57 (13.9)	1.96 (17.3)	2.35 (20.8)	2.94 (26.0)	3.14 (27.8)	3.92 (34.7)	4.70 (41.6)	5.59 (49.5)	6.27 (55.5)	7.55 (66.8)	9.11 (80.6)	11.0 (97.4)	15.2 (135)	17.8 (158)							19.6 (173)
	60Hz	0.78 (6.9)	0.98 (8.7)	1.37 (12.1)	1.57 (13.9)	1.96 (17.3)	2.35 (20.8)	2.65 (23.5)	3.33 (29.5)	3.92 (34.7)	4.70 (41.6)	5.29 (46.8)	6.47 (57.3)	7.55 (66.8)	9.11 (80.6)	12.6 (112)	15.2 (135)							19.6 (173)
Rotational direction	Same as motor rotational direction						Reverse to motor rotational direction						Same as motor rotational direction											

## Permissible torque at output shaft of gear head using decimal gear head

Applicable gear head		Reduction ratio	Speed (min <sup>-1</sup> )											
Bearing	Decimal gear head		250	300	360	500	600	750	900	1000	1200	1500	1800	
		MZ9G□B (ball bearing / hinge not attached) MY9G□B (ball bearing / hinge attached)	MZ9G10XB	Speed	6	5	4.2	3	2.5	2	1.7	1.5	1.3	1
60Hz	7.2			6	5	3.6	3	2.4	2	1.8	1.5	1.2	1	
		Permissible torque	N·m (173)	19.6 (173)	19.6 (173)	19.6 (173)	19.6 (173)	19.6 (173)	19.6 (173)	19.6 (173)	19.6 (173)	19.6 (173)	19.6 (173)	
		Rotational direction	Reverse to motor rotational direction			Same as motor rotational direction								

## Connection diagram

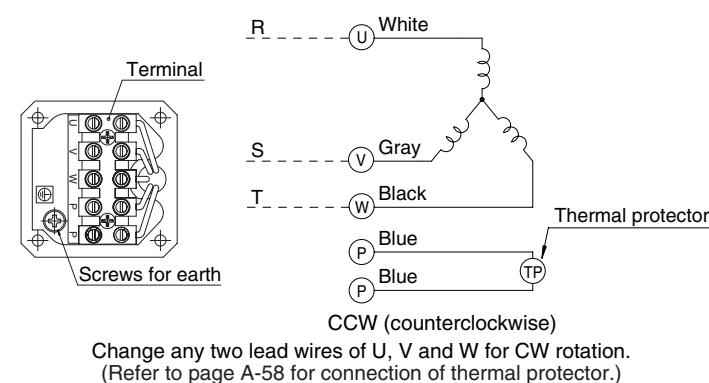

## Speed-torque characteristics

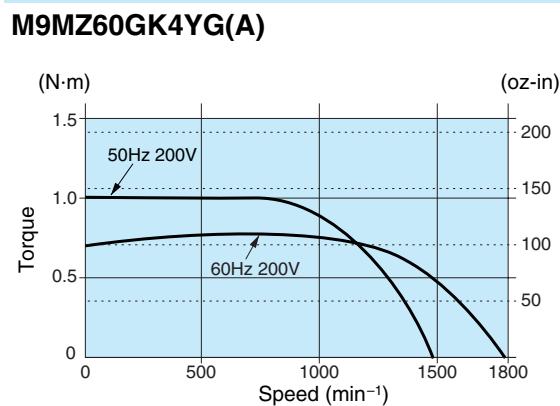

## Motor (dimensions)

Scale: 1/4, Unit: mm (inch)

**M9MZ60GK4YG(A)** 4P 60 W 200 V / 220 V / 230 V (with fan)  
**M9MZ60GK4CG(A)** 4P 60 W 380 V / 400 V (with fan)

Mass **3.0 kg**  
**6.61 lb**  
 Helical gear  
 Module **0.6**  
 Number of teeth **9**

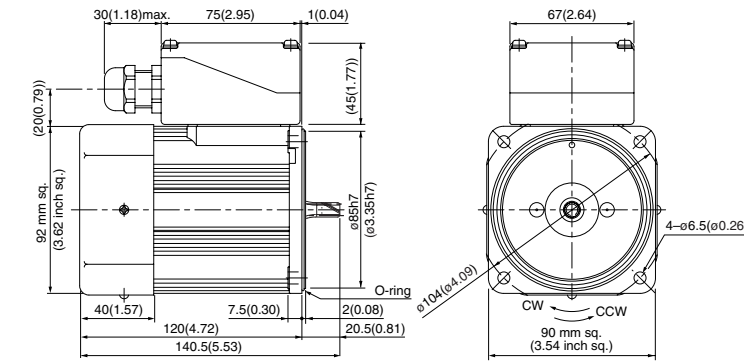

\* Diameter of applicable cable to be ø8(ø0.31) to ø12(ø0.47).

\* Please read your User's manual carefully so that you will understand the operation and safety precautions before attempting to operate the system.

## Gear head (dimensions)

Scale: 1/4, Unit: mm (inch)

**MZ9G□B** (ball bearing / hinge not attached)  
 Mass 1.4 kg (3.09 lb)

**MY9G□B** (ball bearing / hinge attached)  
 Mass 1.4 kg (3.09 lb)

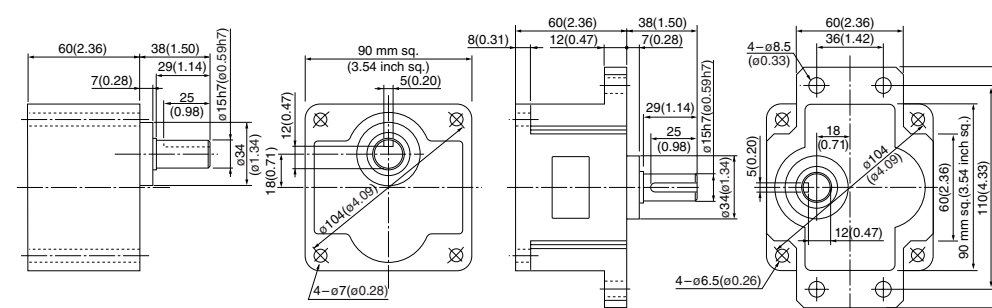

## Key and keyway (dimensions) [attachment]

**MZ9G□B**  
**MY9G□B**

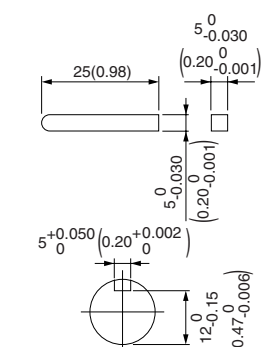

Note) MZ / MY is available for a gear head of either type.

(Note) Because the dimensions may be subject to change, also check the determinate dimensions if the gear head is to be used for design.

# 3-phase motor (sealed connector)

90 mm (3.54 inch) sq. 90 W

## Specifications

Size	Motor model No.	Number of pole (P)	Output (W)	Voltage (V)	Frequency (Hz)	Rating (min)	Rating				Starting current (A)	Starting torque N-m (oz-in)
							Input (W)	Current (A)	Speed (min <sup>-1</sup> )	Torque N-m (oz-in)		
90 mm sq.	M9MZ90GK4Y	4	90	200	50	Cont.	141	0.62	1350	0.63 (89.2)	2.0	1.6 (227)
							137	0.56	1625	0.53 (75.1)	1.8	1.1 (156)
				220	50	Cont.	143	0.65	1400	0.62 (87.8)	2.2	2.0 (283)
							137	0.56	1650	0.52 (73.6)	2.0	1.4 (198)

\* The specifications and wire connections of the round shaft motor are the same as those of the pinion shaft type. For the dimensional outline drawing, refer to page B-165.

## Permissible torque at output shaft of gear head

\* The speed shown below is a calculated value based on the synchronous rotational speed. Depending on the load, the speed is less than the indicated value by 2 to 20%.

Unit of permissible torque: upper (N·m) / lower (lb-in)

Reduction ratio	3	3.6	5	6	7.5	9	10	12.5	15	18	20	25	30	36	50	60	75	90	100	120	150	180	200				
Speed (min <sup>-1</sup> )	50Hz	500	416.7	300	250	200	166.7	150	120	100	83.3	75	60	50	41.7	30	25	20	16.7	15	12.5	10	8.3	7.5			
	60Hz	600	500	360	300	240	200	180	144	120	100	90	72	60	50	36	30	24	20	18	15	12	10	9			
Applicable gear head	MZ9G3B to MZ9G200B (ball bearing / hinge not attached) MY9G3B to MY9G200B (ball bearing / hinge attached)	50Hz	1.37 (12.1)	1.67 (14.8)	2.25 (19.9)	2.74 (24.3)	3.43 (30.4)	4.12 (36.5)	4.51 (39.9)	5.68 (50.3)	6.76 (59.8)	8.04 (71.2)	9.02 (79.8)	10.9 (96.5)	13.0 (115)	15.7 (139)	19.6 (173)										
		60Hz	1.18 (10.4)	1.37 (12.1)	1.86 (16.5)	2.25 (19.9)	2.84 (25.1)	3.43 (30.4)	3.72 (32.9)	4.70 (41.6)	5.68 (50.3)	6.76 (59.8)	7.55 (66.8)	9.21 (81.5)	10.9 (96.5)	13.0 (115)	18.3 (162)										
Rotational direction	Same as motor rotational direction						Reverse to motor rotational direction						Same as motor rotational direction														

## Permissible torque at output shaft of gear head using decimal gear head

Applicable gear head		Reduction ratio	250	300	360	500	600	750	900	1000	1200	1500	1800
Bearing	Decimal gear head	Speed (min <sup>-1</sup> )	50Hz	6	5	4.2	3	2.5	2	1.7	1.5	1.3	0.8
		60Hz	7.2	6	5	3.6	3	2.4	2	1.8	1.5	1.2	1
MZ9G□B (ball bearing / hinge not attached) MY9G□B (ball bearing / hinge attached)	MZ9G10XB	Permissible torque	N·m (lb-in)	19.6 (173)	19.6 (173)	19.6 (173)	19.6 (173)	19.6 (173)	19.6 (173)	19.6 (173)	19.6 (173)	19.6 (173)	19.6 (173)
		Rotational direction	Reverse to motor rotational direction			Same as motor rotational direction							

## Motor (dimensions)

Scale: 1/4, Unit: mm (inch)

M9MZ90GK4Y 4P 90 W 200 V / 220 V (with fan)

Mass 3.3 kg 7.28 lb  
Helical gear  
Module 0.6  
Number of teeth 9

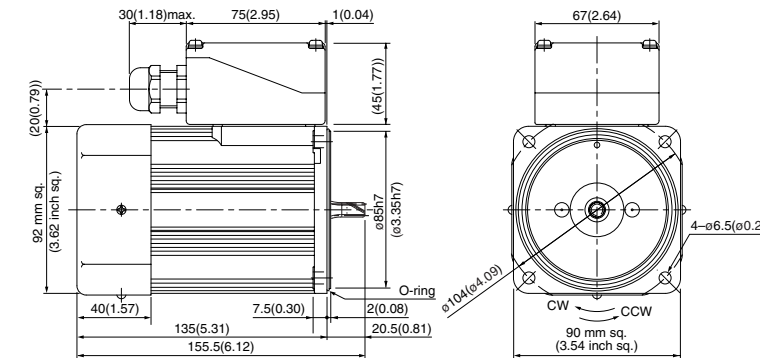

\* Diameter of applicable cable to be ø8(ø0.31) to ø12(ø0.47).

## Connection diagram

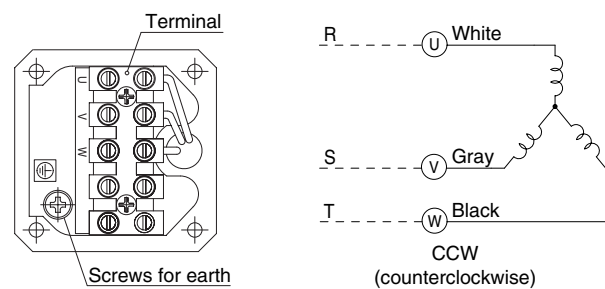

Change any two lead wires of U, V and W for CW rotation.

## Speed-torque characteristics

M9MZ90GK4Y

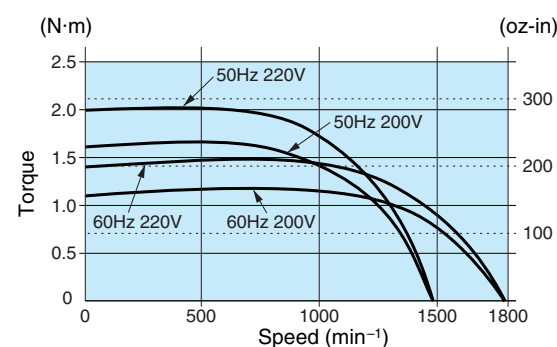

## Gear head (dimensions)

Scale: 1/4, Unit: mm (inch)

MZ9G□B (ball bearing / hinge not attached)  
Mass 1.4 kg (3.09 lb)

MY9G□B (ball bearing / hinge attached)  
Mass 1.4 kg (3.09 lb)

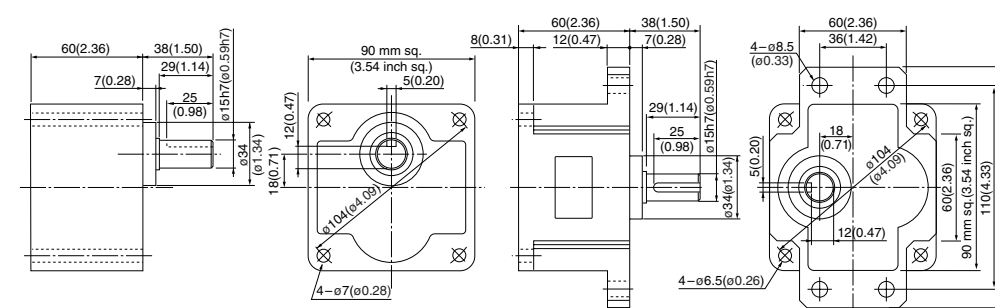

## Key and keyway (dimensions) [attachment]

MZ9G□B  
MY9G□B

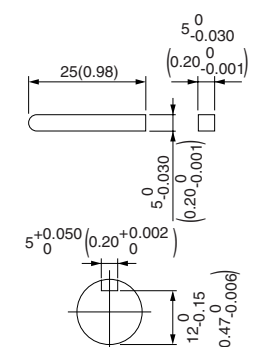

Note) MZ / MY is available for a gear head of either type.

(Note) Because the dimensions may be subject to change, also check the determinate dimensions if the gear head is to be used for design.

# 3-phase motor (sealed connector)

## Specifications

Size	Motor model No.	Number of pole (P)	Output (W)	Voltage (V)	Frequency (Hz)	Rating (min)	Rating				Starting current (A)	Starting torque N-m (oz-in)
							Input (W)	Current (A)	Speed (min <sup>-1</sup> )	Torque N-m (oz-in)		
90 mm sq.	M9MZ90GK4YG M9MZ90GK4YGA	4	90	200	50	Cont.	142	0.62	1350	0.63 (89.2)	2.0	1.6 (227)
							138	0.56	1625	0.53 (75.1)	1.8	1.1 (156)
				220	137		0.56	1650	0.52 (73.6)	2.0	1.4 (198)	
					137		0.58	1675	0.51 (72.2)	2.1	1.6 (227)	
380	50	Cont.	144	0.31	1325	0.65 (92.0)	1.0	1.4 (198)				
			400	144	0.31	1350	0.64 (90.6)	1.0	1.6 (227)			

• The specifications and wire connections of the round shaft motor are the same as those of the pinion shaft type. For the dimensional outline drawing, refer to page B-165.  
 • The models with a motor model number to which "A" is suffixed are not sold or available in Japan.

## Permissible torque at output shaft of gear head

\* The speed shown below is a calculated value based on the synchronous rotational speed. Depending on the load, the speed is less than the indicated value by 2 to 20%.

Unit of permissible torque: upper (N·m) / lower (lb·in)

Reduction ratio	Speed (min <sup>-1</sup> )																									
	50Hz	60Hz	500	416.7	300	250	200	166.7	150	120	100	83.3	75	60	50	41.7	30	25	20	16.7	15	12.5	10	8.3	7.5	
Applicable gear head MZ9G3B to MZ9G200B (ball bearing / hinge not attached) MY9G3B to MY9G200B (ball bearing / hinge attached)	50Hz	1.37 (12.1)	1.67 (14.8)	2.25 (19.9)	2.74 (24.3)	3.43 (30.4)	4.12 (36.5)	4.51 (39.9)	5.68 (50.3)	6.76 (59.8)	8.04 (71.2)	9.02 (79.8)	10.9 (96.5)	13.0 (115)	15.7 (139)	19.6 (173)										
	60Hz	1.18 (10.4)	1.37 (12.1)	1.86 (16.5)	2.25 (19.9)	2.84 (25.1)	3.43 (30.4)	3.72 (32.9)	4.70 (41.6)	5.68 (50.3)	6.76 (59.8)	7.55 (66.8)	9.21 (81.5)	10.9 (96.5)	13.0 (115)	18.3 (162)										

## Permissible torque at output shaft of gear head using decimal gear head

Applicable gear head	Reduction ratio	Speed (min <sup>-1</sup> )												
		250	300	360	500	600	750	900	1000	1200	1500	1800		
Bearing MZ9G□B (ball bearing / hinge not attached) MY9G□B (ball bearing / hinge attached)	Decimal gear head MZ9G10XB	Speed												
		50Hz	6	5	4.2	3	2.5	2	1.7	1.5	1.3	1	0.8	
		60Hz	7.2	6	5	3.6	3	2.4	2	1.8	1.5	1.2	1	
		Permissible torque	N·m	19.6 (173)	19.6 (173)	19.6 (173)	19.6 (173)	19.6 (173)	19.6 (173)	19.6 (173)	19.6 (173)	19.6 (173)	19.6 (173)	
		Rotational direction	Reverse to motor rotational direction			Same as motor rotational direction								

## Connection diagram

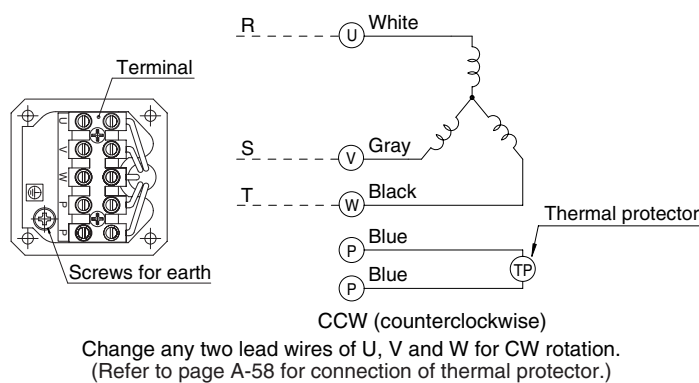

## Speed-torque characteristics

### M9MZ90GK4YG(A)

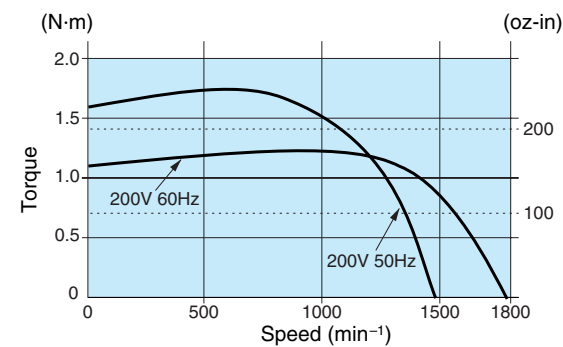

## Motor (dimensions)

Scale: 1/4, Unit: mm (inch)

<b>M9MZ90GK4YG(A)</b>	4P 90 W 200 V / 220 V / 230 V (with fan)
<b>M9MZ90GK4CG(A)</b>	4P 90 W 380 V / 400 V (with fan)

Mass	3.3 kg 7.28 lb	Helical gear	Module	0.6	Number of teeth	9
------	-------------------	--------------	--------	-----	-----------------	---

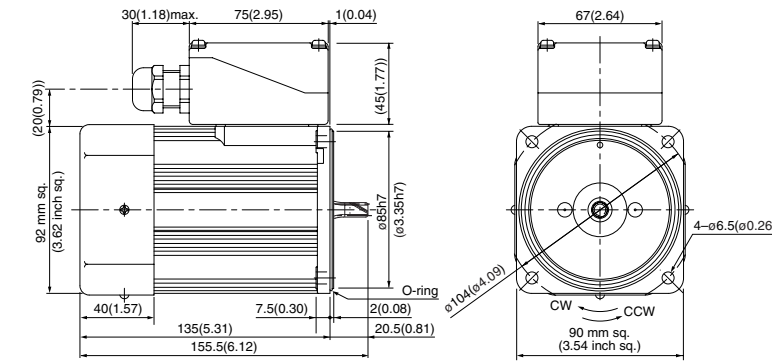

\* Diameter of applicable cabtyre cable to be  $\phi 8(\phi 0.31)$  to  $\phi 12(\phi 0.47)$ .

\* Please read your User's manual carefully so that you will understand the operation and safety precautions before attempting to operate the system.

## Gear head (dimensions)

Scale: 1/4, Unit: mm (inch)

**MZ9G□B** (ball bearing / hinge not attached)  
Mass 1.4 kg (3.09 lb)

**MY9G□B** (ball bearing / hinge attached)  
Mass 1.4 kg (3.09 lb)

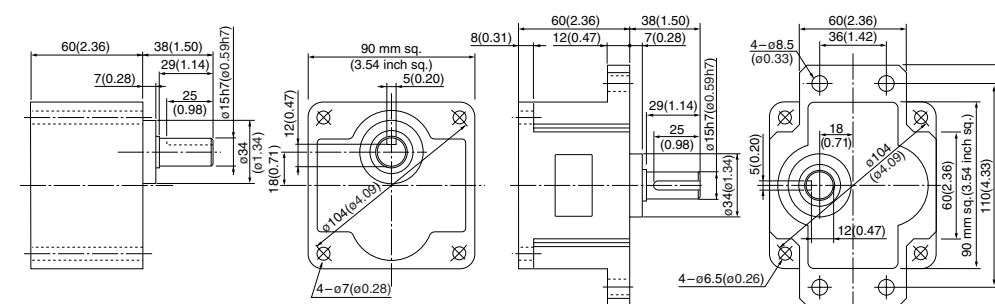

## Key and keyway (dimensions) [attachment]

**MZ9G□B**  
**MY9G□B**

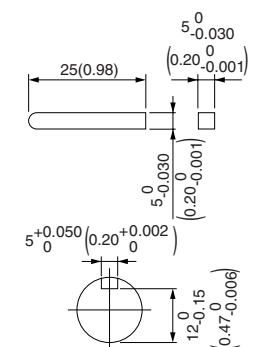

Note) MZ / MY is available for a gear head of either type.

Note) Because the dimensions may be subject to change, also check the determinate dimensions if the gear head is to be used for design.

Induction motor  
 Reversible motor  
 3-phase motor  
 Electromagnetic brake motor  
 Variable speed induction motor  
 Variable speed reversible motor  
 Variable speed electromagnetic brake single-phase motor  
 Variable speed unit motor  
 C&B motor  
 2-pole round shaft motor  
 Gear head  
 Gear head -inch (U.S.A.)

### 3-phase motor (leadwire)

Gear head combination dimensions  
Scale: 1/4, Unit: mm (inch)

**80 mm sq. (3.15 inch sq.) 25 W**

M8MX25G4Y + MX8G□B(M)  
M8MX25G4YG(A) + MX8G□B(M)

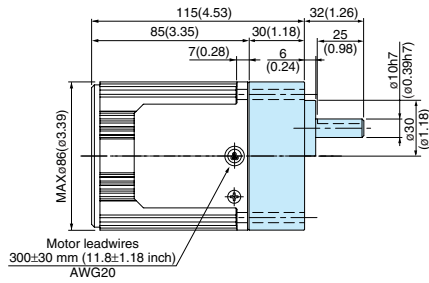

**90 mm sq. (3.54 inch sq.) 40 W**

M9MX40G4Y + MX9G□B(M)  
M9MX40G4YG(A) + MX9G□B(M)

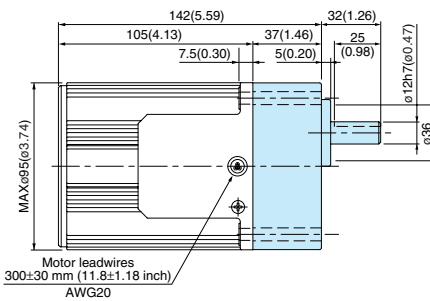

**90 mm sq. (3.54 inch sq.) 60 W**

M9MZ60G4Y + MZ9G□B (MY9G□B)  
M9MZ60G4YG(A) + MZ9G□B (MY9G□B)

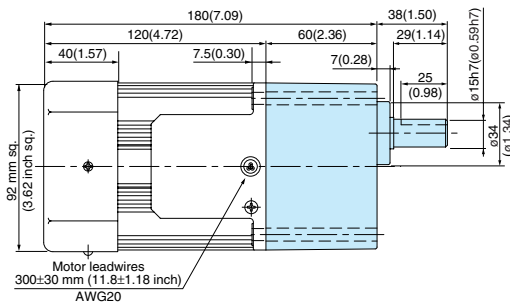

\* Refer to page B-444 for high torque gear head.

**90 mm sq. (3.54 inch sq.) 90 W**

M9MZ90G4Y + MY9G□B (MZ9G□B)  
M9MZ90G4YG(A) + MY9G□B (MZ9G□B)

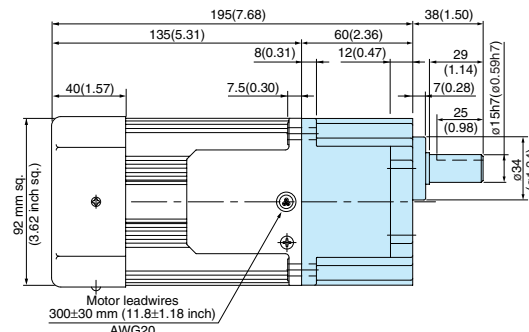

\* Refer to page B-444 for high torque gear head.

### 3-phase motor (sealed connector)

Gear head combination dimensions  
Scale: 1/4, Unit: mm (inch)

**80 mm sq. (3.15 inch sq.) 25 W**

M8MX25GK4Y + MX8G□B(M)  
M8MX25GK4YG(A) + MX8G□B(M)  
M8MX25GK4CG(A) + MX8G□B(M)

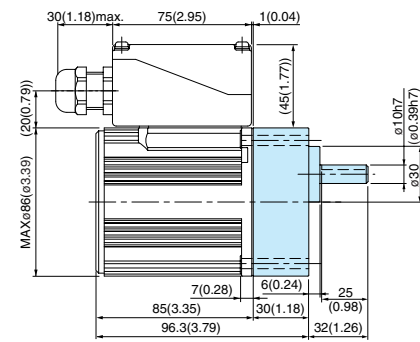

\* Diameter of applicable cabtyre cable to be ø8(ø0.31) to ø12(ø0.47).

**90 mm sq. (3.54 inch sq.) 40 W**

M9MX40GK4Y + MX9G□B(M)  
M9MX40GK4YG(A) + MX9G□B(M)  
M9MX40GK4CG(A) + MX9G□B(M)

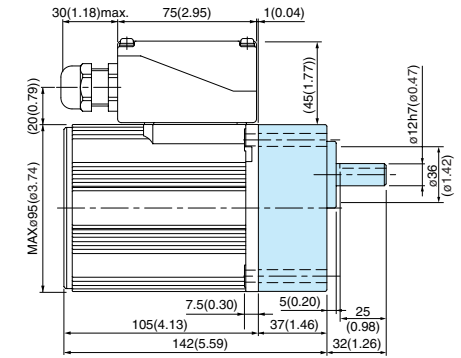

\* Diameter of applicable cabtyre cable to be ø8(ø0.31) to ø12(ø0.47).

**90 mm sq. (3.54 inch sq.) 60 W**

M9MZ60GK4Y + MZ9G□B (MY9G□B)  
M9MZ60GK4YG(A) + MZ9G□B (MY9G□B)  
M9MZ60GK4CG(A) + MZ9G□B (MY9G□B)

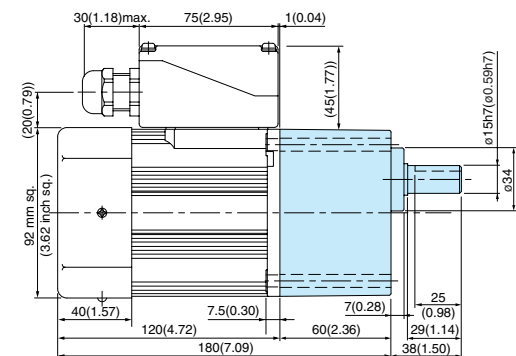

\* Diameter of applicable cabtyre cable to be ø8(ø0.31) to ø12(ø0.47).

\* Refer to page B-444 for high torque gear head.

**90 mm sq. (3.54 inch sq.) 90 W**

M9MZ90GK4Y + MY9G□B (MZ9G□B)  
M9MZ90GK4YG(A) + MY9G□B (MZ9G□B)  
M9MZ90GK4CG(A) + MY9G□B (MZ9G□B)

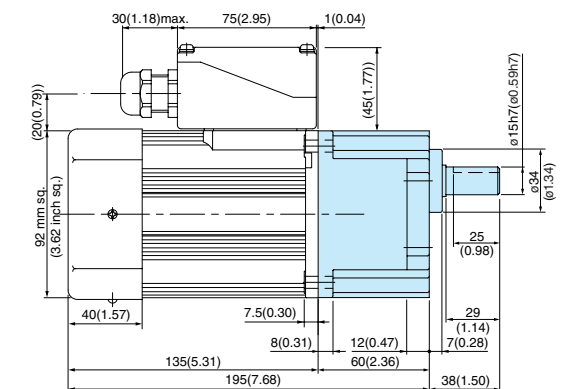

\* Diameter of applicable cabtyre cable to be ø8(ø0.31) to ø12(ø0.47).

\* Refer to page B-444 for high torque gear head.

\* Please read your User's manual carefully so that you will understand the operation and safety precautions before attempting to operate the system.

\*The models with a motor model number to which "A" is suffixed are not sold or available in Japan.

(Note) Because the dimensions may be subject to change, also check the determinate dimensions if the gear head is to be used for design.

Induction motor  
Reversible motor  
3-phase motor  
Electromagnetic brake motor  
Variable speed induction motor  
Variable speed reversible motor  
Variable speed electromagnetic brake single-phase motor  
Variable speed unit motor  
C&B motor  
2-pole round shaft motor  
Gear head  
Gear head -inch (U.S.A.)

### 3-phase motor (4-pole round shaft / leadwire)

**Dimensions**  
Scale: 1/4, Unit: mm (inch)

**80 mm sq. (3.15 inch sq.) 25 W** **Mass 1.5 kg (3.31 lb)**  
**M8MX25S4YS**  
**M8MX25S4YG(A)**

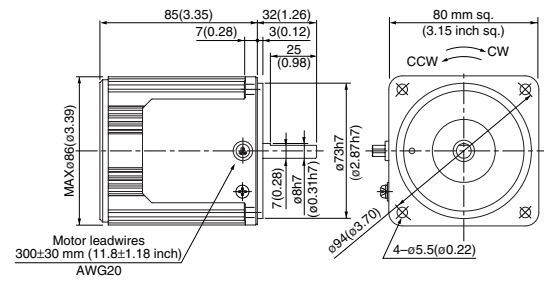

**90 mm sq. (3.54 inch sq.) 40 W** **Mass 2.4 kg (5.29 lb)**  
**M9MX40S4YS**  
**M9MX40S4YG(A)**

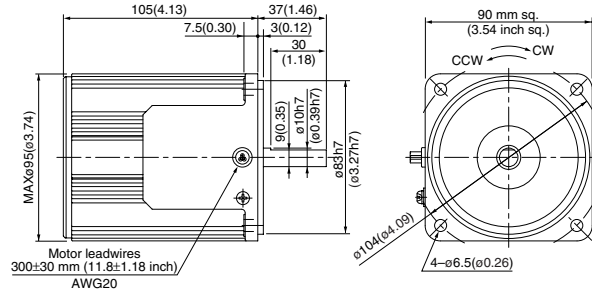

**90 mm sq. (3.54 inch sq.) 60 W** **Mass 2.7 kg (5.95 lb)**  
**M9MZ60S4YS (with fan)**  
**M9MZ60S4YG(A) (with fan)**

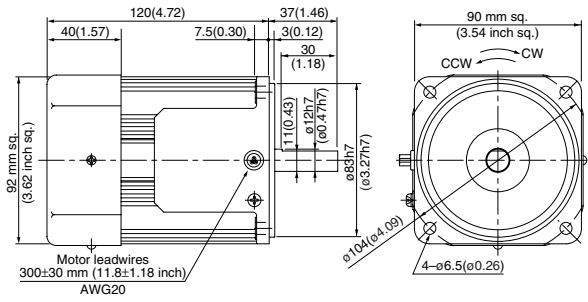

**90 mm sq. (3.54 inch sq.) 90 W** **Mass 3.2 kg (7.05 lb)**  
**M9MZ90S4YS (with fan)**  
**M9MZ90S4YG(A) (with fan)**

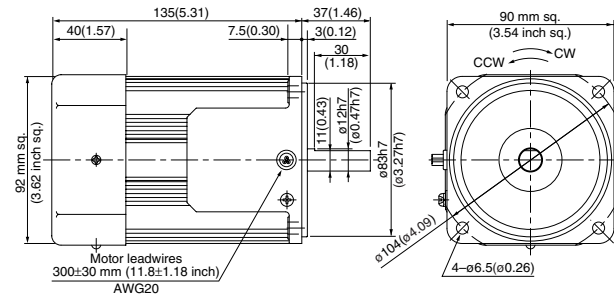

### 3-phase motor (4-pole round shaft / sealed connector)

**Dimensions**  
Scale: 1/4, Unit: mm (inch)

**80 mm sq. (3.15 inch sq.) 25 W** **Mass 1.8 kg (3.97 lb)**  
**M8MX25SK4YS** **M8MX25SK4YG(A)**  
**M8MX25SK4CG(A)**

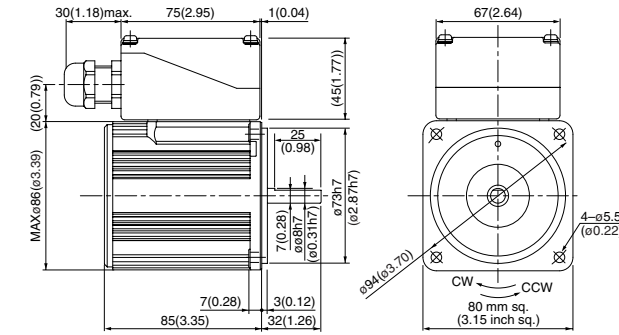

\* Diameter of applicable cabtyre cable to be ø8(ø0.31) to ø12(ø0.47).

**90 mm sq. (3.54 inch sq.) 40 W** **Mass 2.8 kg (6.17 lb)**  
**M9MX40SK4YS** **M9MX40SK4YG(A)**  
**M9MX40SK4CG(A)**

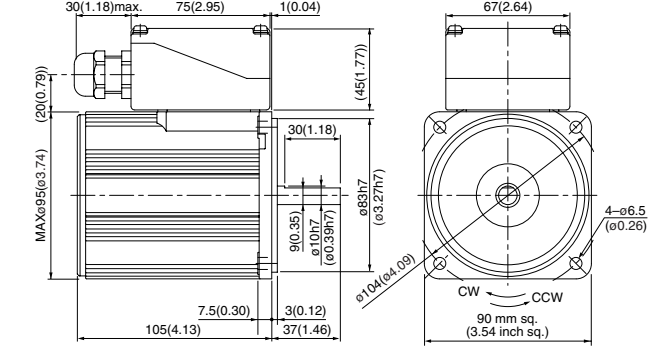

\* Diameter of applicable cabtyre cable to be ø8(ø0.31) to ø12(ø0.47).

**90 mm sq. (3.54 inch sq.) 60 W** **Mass 3.0 kg (6.61 lb)**  
**M9MZ60SK4YS (with fan)**  
**M9MZ60SK4YG(A) (with fan)**  
**M9MZ60SK4CG(A) (with fan)**

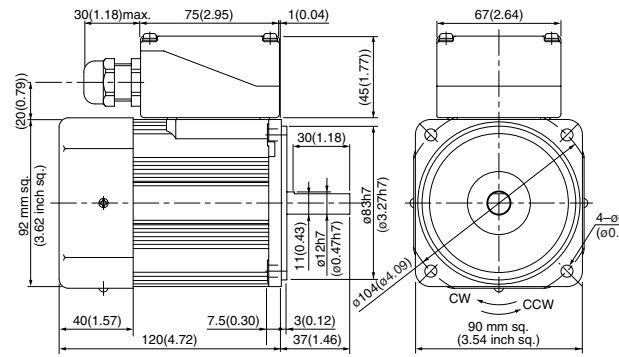

\* Diameter of applicable cabtyre cable to be ø8(ø0.31) to ø12(ø0.47).

**90 mm sq. (3.54 inch sq.) 90 W** **Mass 3.3 kg (7.28 lb)**  
**M9MZ90SK4YS (with fan)**  
**M9MZ90SK4YG(A) (with fan)**  
**M9MZ90SK4CG(A) (with fan)**

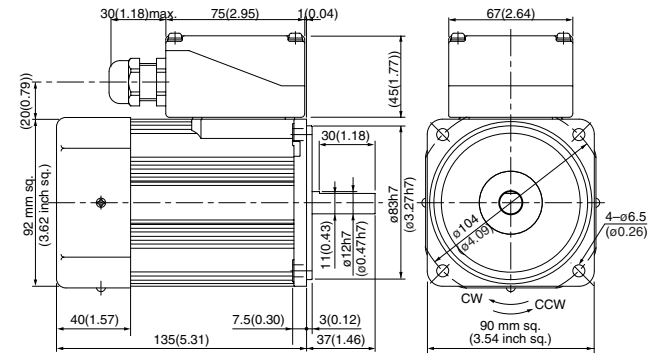

\* Diameter of applicable cabtyre cable to be ø8(ø0.31) to ø12(ø0.47).

200 V/220 V/230 V round shaft motors with a sealed connector (with a terminal box) are covered by the Electrical Appliance and Material Safety Law. The indications on their nameplate are based on this law.

\* Please read your User's manual carefully so that you will understand the operation and safety precautions before attempting to operate the system.

\*The models with a motor model number to which "A" is suffixed are not sold or available in Japan.

(Note) Because the dimensions may be subject to change, also check the determinate dimensions if the gear head is to be used for design.

- Induction motor
- Reversible motor
- 3-phase motor
- Electromagnetic brake motor
- Variable speed induction motor
- Variable speed reversible motor
- Variable speed electromagnetic brake single-phase motor
- Variable speed unit motor
- C&B motor
- 2-pole round shaft motor
- Gear head
- Gear head -1inch (U.S.A.)

