

**1.8°, 0.72° and 0.36°
Stepper Motor and Driver Package**

CVK Series

DC Input

Compact, standardized drivers, combined with performance driven high torque stepper motors, for the optimum results.

20 mm, 28 mm, 35 mm, 42 mm, 56.4 mm or 60 mm

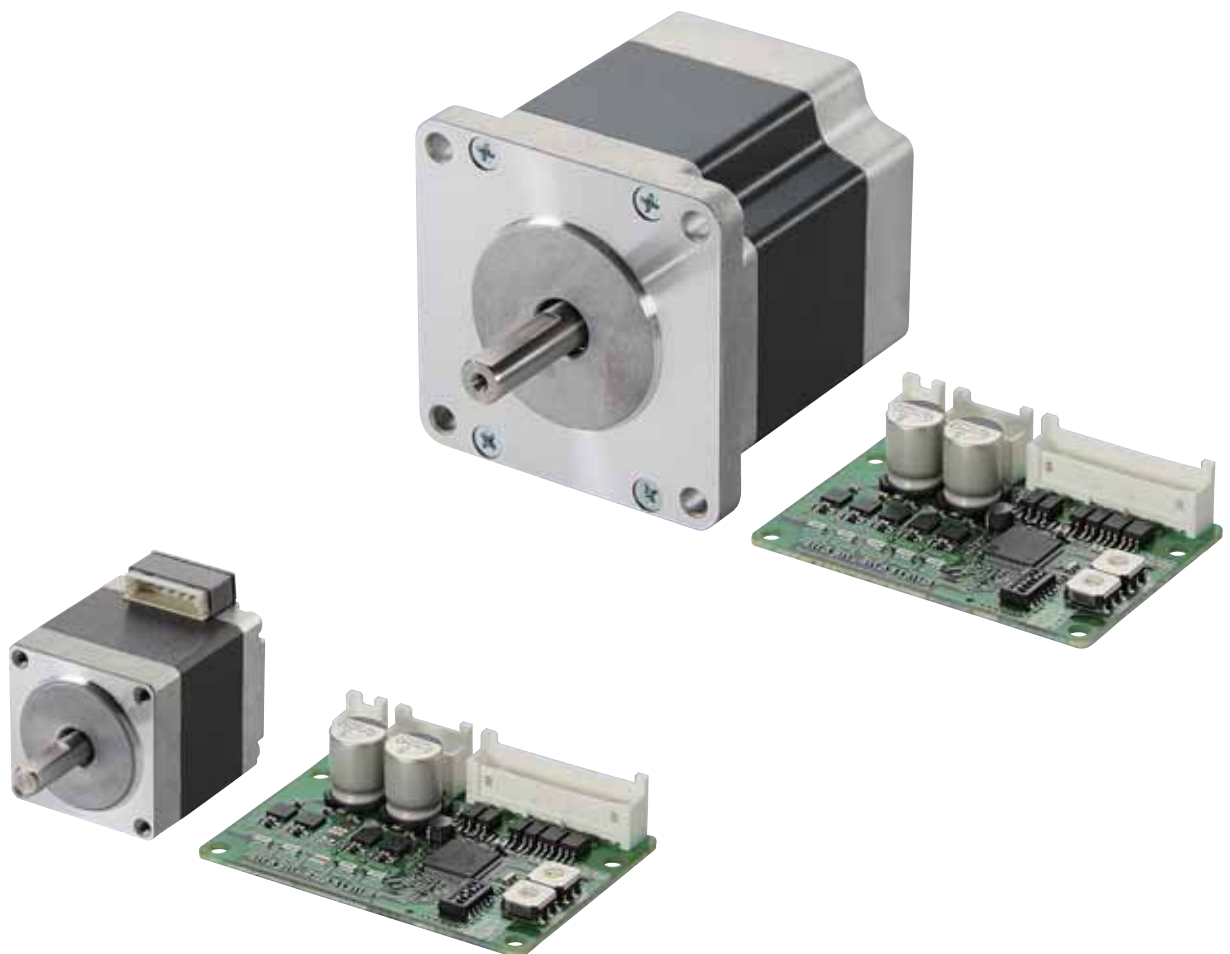

1.8° Stepper Motor

1.8° motor and driver packages now have the highest torque in the low-speed range. With Oriental Motor's higher current stepper motors and superior microstepping performance, low vibration is achieved throughout the speed range.

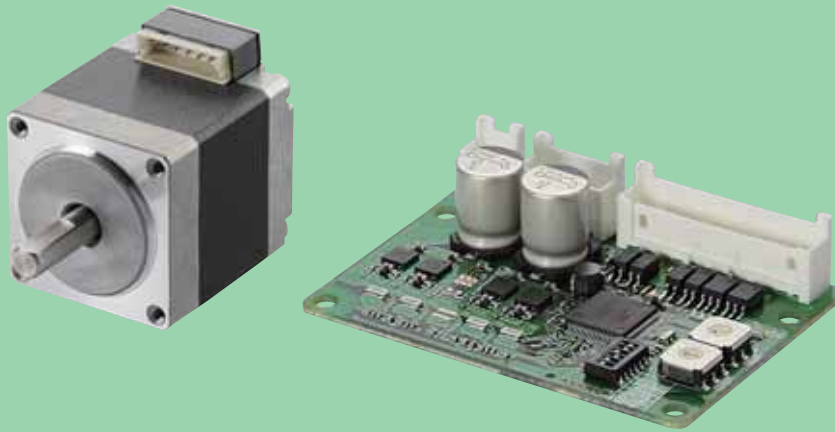

Revisions to the motor winding design and a high-efficiency driver circuit design allow for significant torque increases in the low-speed range. In particular, torque in the 250 r/min range has been increased by 50% compared to conventional products allowing for quicker moves. Vibration and noise have been greatly reduced compared to conventional 1.8° stepper motor performance.

● Comparison of 1.8° Stepper Motor Torque Characteristics

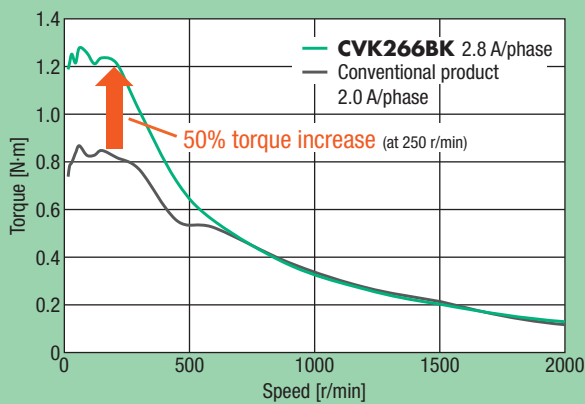

The maximum holding torque has increased with a bipolar winding.

● Comparison of 1.8° Stepper Motor Vibration Characteristics

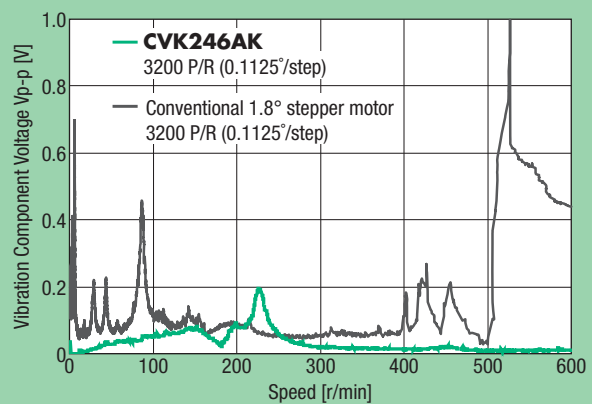

The vibration characteristics have been significantly improved across all speed ranges with the fully digital-controlled microstep driver.

0.72° and 0.36° Stepper Motor

0.72° and 0.36° motor and driver packages have higher torque in the upper speed ranges. With Oriental Motor's motor technology and microstepping performance, even greater positional accuracy, lower vibration and noise are achieved.

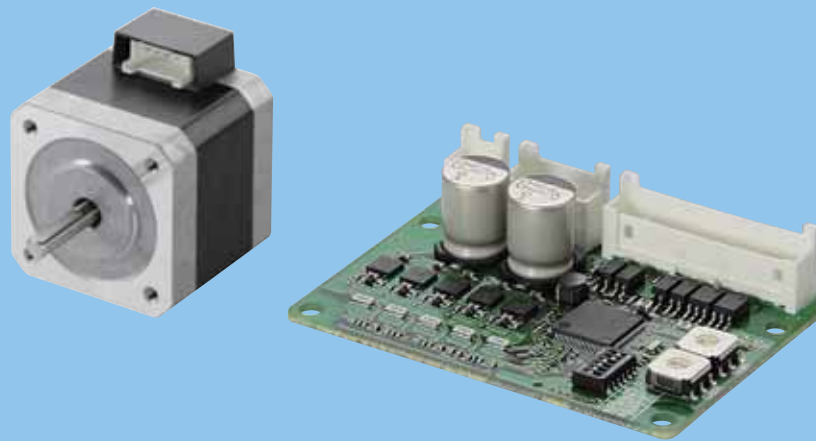

Through revisions to the motor winding design and a high-efficiency driver circuit design, the performance of 0.72°/0.36° stepper motors has been brought to their full potential, resulting in significant increases in torque in all speed ranges. Torque in the 500 r/min range has increased by 85% compared to conventional products. In addition, the fully digital-controlled microstep driver has further improved the low vibration and noise reduction factors.

● Comparison of 0.72°/0.36° Stepper Motor Torque Characteristics

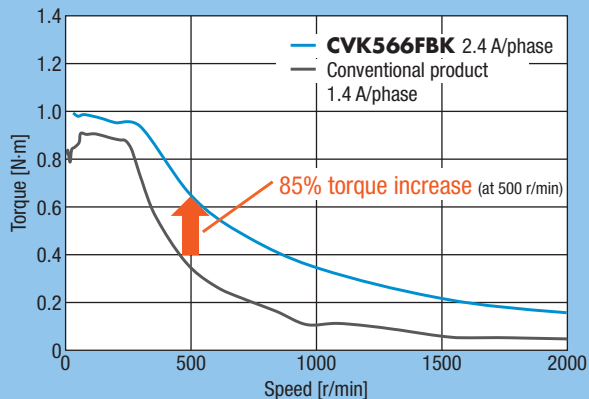

By adopting a higher current motor winding specification, the usage range is now much wider.

● Comparison of 0.72°/0.36° Stepper Motor Vibration Characteristics

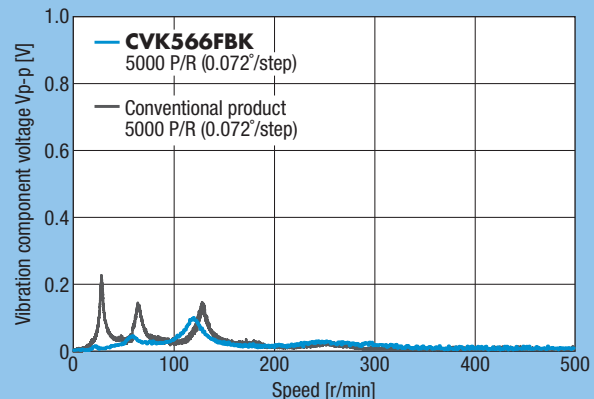

Lower vibration and further noise reductions have been achieved through the use of a fully digital-controlled microstep driver.

Superior Performance with 1.8° or 0.72°/0.36° Stepper Motor and Driver Packages

A Significant Torque Increase Allows for More Applications

The maximum holding torque in the low-speed range is achieved with the 1.8° motor and driver packages through the use of a high motor current design and specification. The speed range has increased considerably with the 0.72°/0.36° packages.

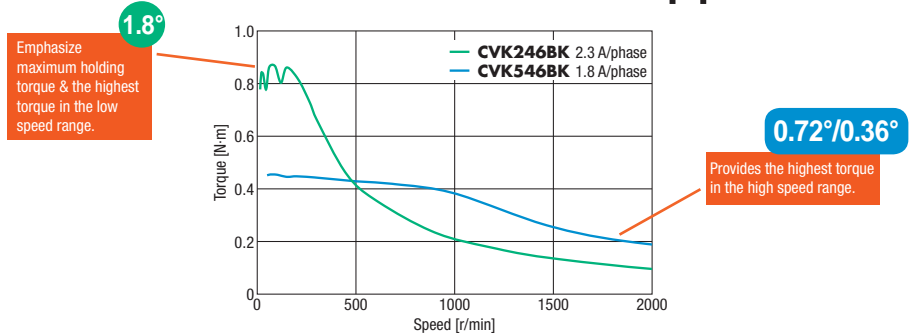

Low Vibration with Full-Time Microstepping

Low vibration and noise reduction have been achieved across all speed ranges by significantly improving the vibration level with the use of a fully digital-controlled full-time microstep driver. The CVK Series 0.72°/0.36° stepper motor has further improved vibration characteristic.

● **Reduced Step Vibration**
The new smooth drive control with higher current control increases the basic step angle to a maximum resolution of 2048. As a result, a reduction in step vibration in the low-speed range is achieved.

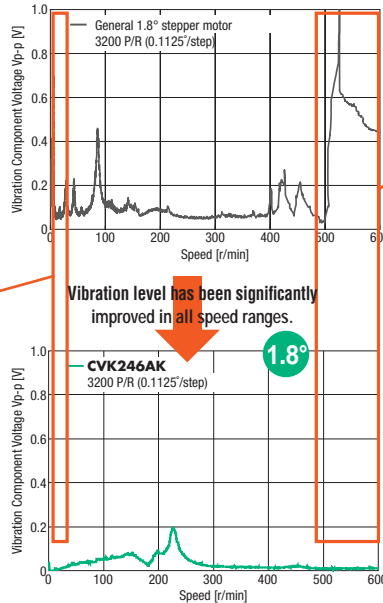

CVK Series
Vibration characteristics for 0.72°/0.36° stepper motors have been further improved.

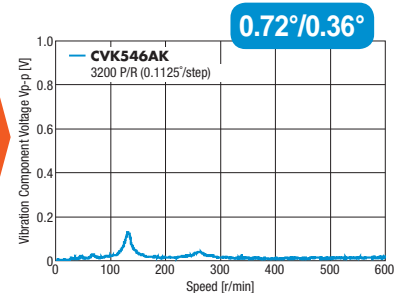

For High Positioning Accuracy Use a 0.72°/0.36° Stepper Motor

In general, stopping accuracy tends to be lower during microstep operation* than full step operation and this effect is more noticeable in a 1.8° motor. In this situation, using a CVK Series 0.72°/0.36° stepper motor enables a higher positioning accuracy.

*Max. resolution 250000 P/R

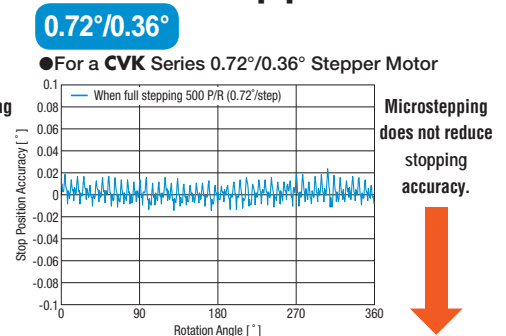
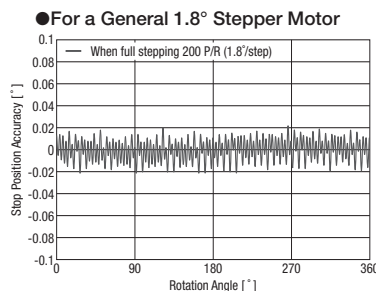

● **Stopping Accuracy**
0.72° stepper motor standard type ±0.05° (±3 min)
0.36° stepper motor high-resolution type ±0.034° (±2 min)

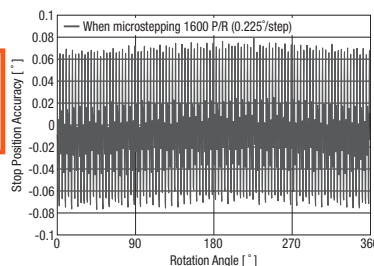

CVK Series
High positioning accuracy is now possible with 0.72°/0.36° stepper motors

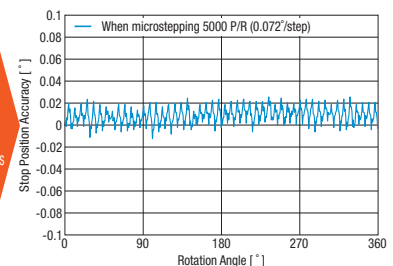

Common Driver Installation and Wiring Allow for the Desired Performance.

There's a Wide Choice with 1.8° and 0.72°/0.36° Stepper Motors

The size, installation and I/O connectors for the **CVK Series** 1.8° and 0.72°/0.36° motor and driver packages are the same. Because of this, it is easy to evaluate and select the proper package for the requirement.

*The driver for a 1.8° stepper motor and the driver for a 0.72°/0.36° stepper motor are not interchangeable. Each motor type has a dedicated driver. Use the Step Angle Setting Switch (page 20) to set the proper resolution without changing your controller's pulse output.

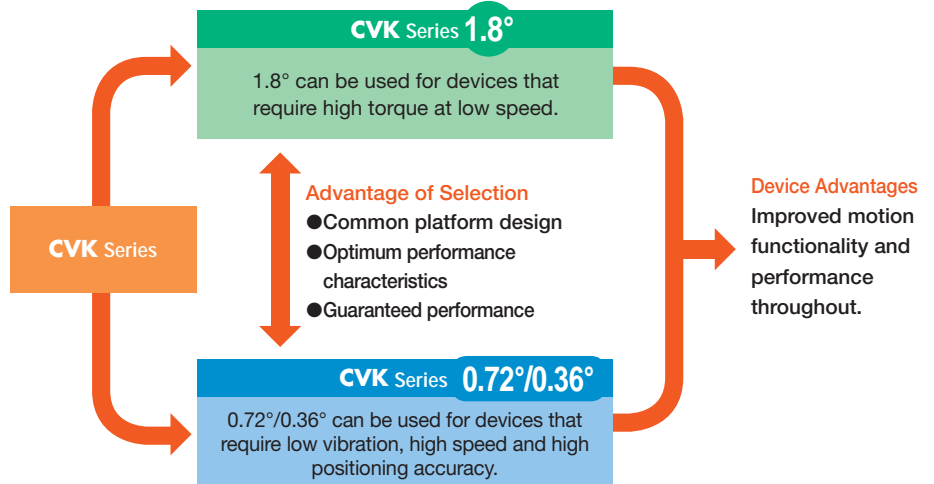

High-Performance Driver in the Industry's Smallest Size Class

- Small and light driver contributes to space saving
- Protective function can detect driver abnormalities early
- Smooth drive microstepping function allows for a smooth operation
- Operation current can be set with a digital switch

- Name and function of each driver component

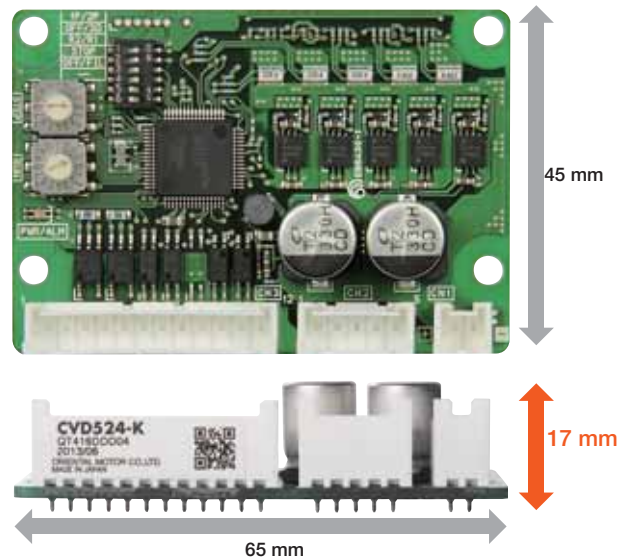
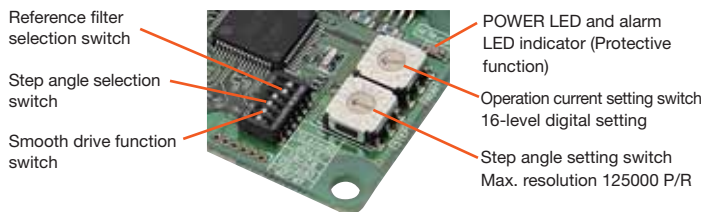

1.8° and 0.72°/0.36° Stepper Motor Packages are Similarly Priced

In addition to improving the performance and function of the **CVK Series**, prices have been revised as well. Now, the price difference between a 1.8° and a 0.72°/0.36° stepper motor is minimal.

- Comparison Between a 1.8° and a 0.72°/0.36° Stepper Motor Packages:

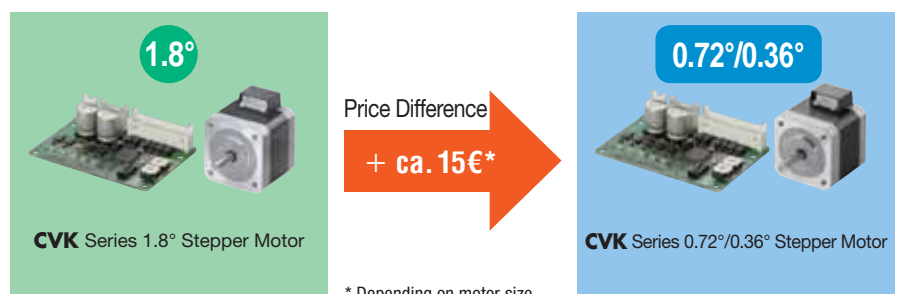

* Depending on motor size.

The **CVK** Series is a stepper motor and driver package designed for guaranteed performance. The motor product line-up includes a 1.8°, 0.72° or 0.36° stepper motor and driver with virtually identical frame sizes. The drivers are compatible in terms of functionality, operation method and installation. Furthermore, the prices of the 1.8° and 0.72°/0.36° stepper motor and driver packages are similar, making them both affordable and attractive.

- Select the optimal performance package to suit the desired specification.

Product Number

CVK 5 6 4 F M A K

① ② ③ ④ ⑤ ⑥ ⑦ ⑧

①	Series Name	CVK: CVK Series
②	2: 1.8° Stepper Motor 5: 0.72°/0.36° Stepper Motor	
③	Motor Frame Size	1: 20 mm 2: 28 mm 3: 35 mm 4: 42 mm 6: 56.4 mm; 60 mm when the motor classification is "F"
④	Motor Case Length	
⑤	Motor Classification	F: Motor frame size 60 mm
⑥	Motor Type	M: High resolution type None: Standard type
⑦	Configuration	A: Single shaft B: Double shaft
⑧	Power-Supply Voltage	K: 24 VDC

Product Line and List Price

1.8° Stepper Motor and Driver Package

Type	Product Name (Single Shaft)	Product Name (Double Shaft)
Standard	CVK213AK	CVK213BK
	CVK223AK	CVK223BK
	CVK225AK	CVK225BK
	CVK233AK	CVK233BK
	CVK235AK	CVK235BK
	CVK243AK	CVK243BK
	CVK244AK	CVK244BK
	CVK245AK	CVK245BK
	CVK246AK	CVK246BK
	CVK264AK*	CVK264BK*
	CVK266AK*	CVK266BK*
	CVK268AK*	CVK268BK*
	CVD228-K / PKP264D28AA-L	CVD228-K / PKP264D28BA-L
	CVD228-K / PKP266D28AA-L	CVD228-K / PKP266D28BA-L
CVD228-K / PKP268D28AA-L	CVD228-K / PKP268D28BA-L	

*Front shaft is $\phi 8$ mm. For $\phi 6.35$ mm shaft, use the **CVD228-K / PKP26□** type.

0.72°/0.36° Stepper Motor and Driver Package

Type	Product Name (Single Shaft)	Product Name (Double Shaft)
Standard	CVK523AK	CVK523BK
	CVK525AK	CVK525BK
	CVK544AK	CVK544BK
	CVK546AK	CVK546BK
	CVK564FAK	CVK564FBK
	CVK566FAK	CVK566FBK
High Resolution	CVK569FAK	CVK569FBK
	CVK544MAK	CVK544MBK
	CVK546MAK	CVK546MBK
	CVK564FMAK	CVK564FMBK
	CVK566FMAK	CVK566FMBK
	CVK569FMAK	CVK569FMBK

The following items are included with each product.

Motor, Driver, Driver Connectors, Connection Cable¹, Operating Manual
1. Only for connector-coupled motor.

System Configuration

An example of a system configuration with the **SCX11** controller shown below.

*Not supplied

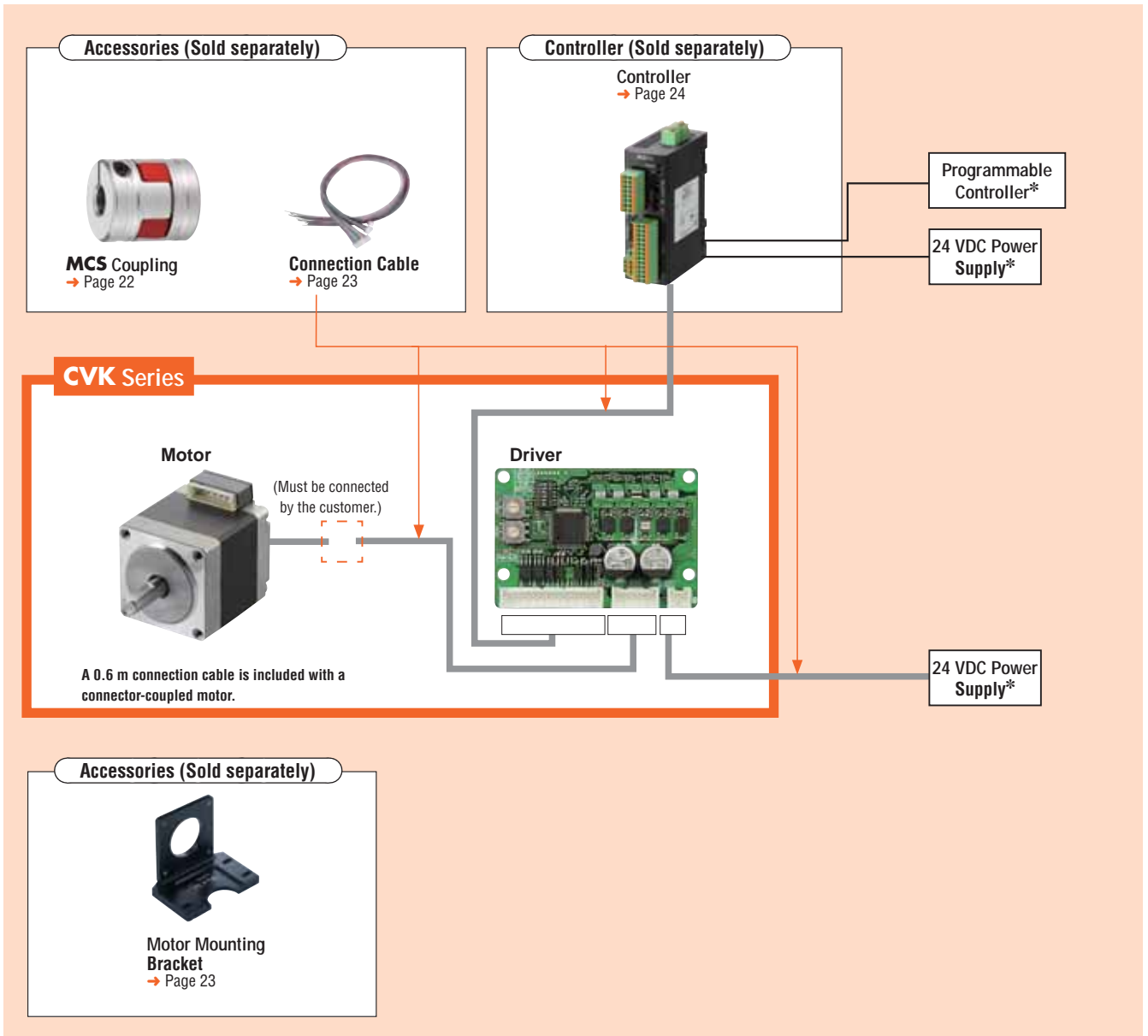

System Configuration Price Example

CVK Series	+	Sold Separately			
		Controller	Motor Mounting Bracket	Flexible Coupling	Connection Cable Set 0.6 m
CVK243AK		SCX11	PALOP	MCS140505	LCS01CVK2

● The system configuration shown above is an example. Other combinations are also available.

1.8° Stepper Motor and Driver Package

Frame Sizes: 20 mm, 28 mm

Standard Type

Specifications



Product Name	Single Shaft	CVK213AK	CVK223AK*	CVK225AK*	
	Double Shaft	CVK213BK	CVK223BK*	CVK225BK*	
Max. Holding Torque	N·m	0.02	0.095	0.19	
Holding Torque at Motor Standstill	N·m	0.01	0.047	0.095	
Rotor Inertia	J: kg·m ²	1.6×10 ⁻⁷	9×10 ⁻⁷	18×10 ⁻⁷	
Rated Current	A/Phase	0.5	1.5		
Basic Step Angle		1.8°			
Power-Supply Voltage		24 VDC±10%	0.5 A	24 VDC±10%	1.3 A
Excitation Mode		Microstep			

* A 0.6 m connection cable is included with a connector-coupled motor.

Speed - Torque Characteristics

CVK213AK/CVK213BK

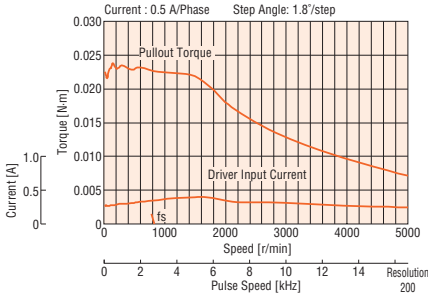

CVK223AK/CVK223BK

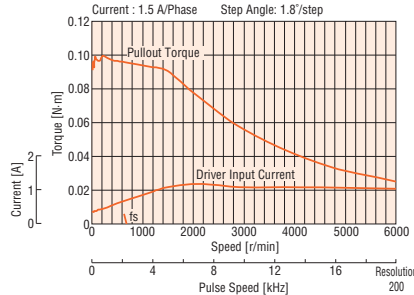

CVK225AK/CVK225BK

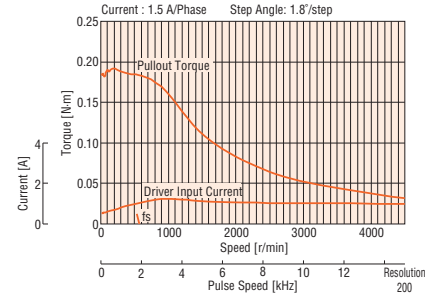

● The pulse input circuit responds up to 1 MHz with a pulse duty of 50%.

Note

● Depending on the driving conditions, a considerable amount of heat may be generated by the motor. Be sure to keep the motor case temperature under 100°C.

Dimensions unit = mm

Product Name	Motor Product Name	L1	L2	Mass kg
CVK213AK	PKP213D05A	30	-	0.05
CVK213BK	PKP213D05B		38	

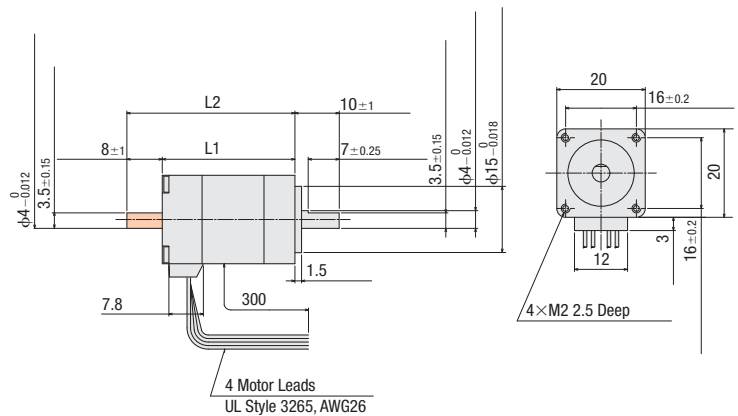

● These dimensions are for double shaft products. For single shaft products, ignore the shaded areas.
● Back shaft of double shaft products have a flat the whole length.

Product Name	Motor Product Name	L1	L2	Mass kg
CVK223AK	PKP223D15A2	32	-	0.11
CVK223BK	PKP223D15B2		42	
CVK225AK	PKP225D15A2	51.5	-	0.2
CVK225BK	PKP225D15B2		61.5	

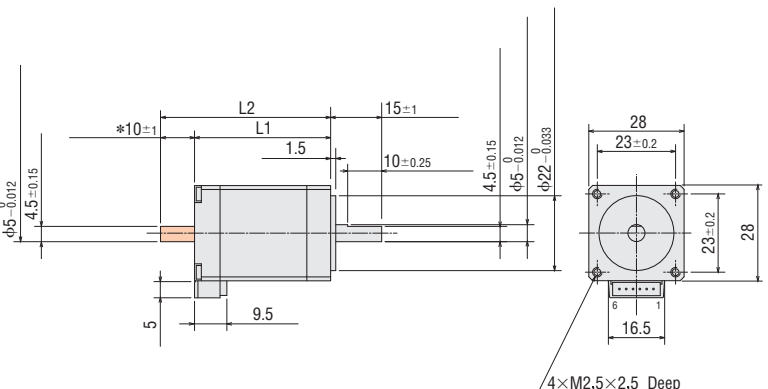

* The length of machining on the double shaft product is 10±0.25.

● These dimensions are for double shaft products. For single shaft products, ignore the shaded areas.

0.72° Stepper Motor and Driver Package

Frame Size: 28 mm

Standard Type

Specifications



Product Name	Single Shaft	CVK523AK	CVK525AK
	Double Shaft	CVK523BK	CVK525BK
Max. Holding Torque	N·m	0.052	0.091
Holding Torque at Motor Standstill	N·m	0.026	0.045
Rotor Inertia	J: kg·m ²	9×10^{-7}	18×10^{-7}
Rated Current	A/Phase	1.2	
Basic Step Angle		0.72°	
Power-Supply Voltage		24 VDC ± 10%	1.7 A
Excitation Mode		Microstep	

● A 0.6 m connection cable is included.

Speed - Torque Characteristics

CVK523AK/CVK523BK

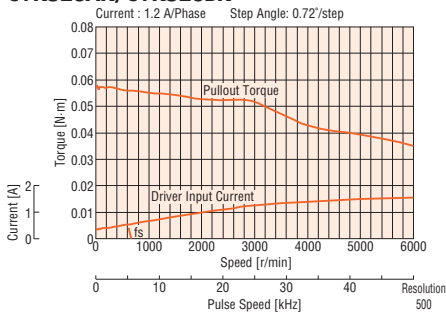

CVK525AK/CVK525BK

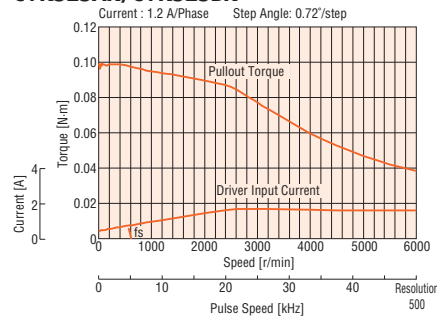

● The pulse input circuit responds up to 1 MHz with a pulse duty of 50%.

Note

● Depending on the driving conditions, a considerable amount of heat may be generated by the motor. Be sure to keep the motor case temperature under 100°C.

Dimensions unit = mm

Product Name	Motor Product Name	L1	L2	Mass kg
CVK523AK	PKP523N12A	32	—	0.11
CVK523BK	PKP523N12B		42	
CVK525AK	PKP525N12A	51.5	—	0.2
CVK525BK	PKP525N12B		61.5	

● A 0.6 m motor connection cable is included with each package : **LC5N06A**

● Applicable Connector

Connector housing: 51065-0500 (Molex)

Contact: 50212-8100 (Molex)

Crimp tool: 57176-5000 (Molex)

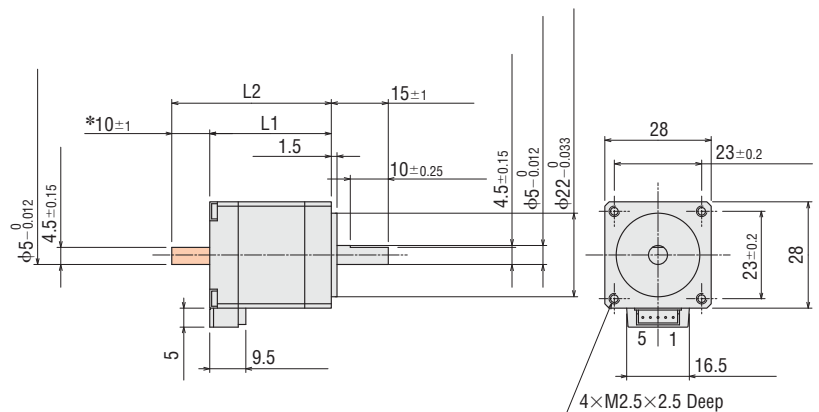

* The length of machining on the double shaft product is 10±0.25.

1.8° Stepper Motor and Driver Package

Frame Size: 35 mm, 42 mm

Standard Type

Specifications



Product Name	Single Shaft	CVK233AK	CVK235AK	CVK243AK	CVK244AK	CVK245AK	CVK246AK
	Double Shaft	CVK233BK	CVK235BK	CVK243BK	CVK244BK	CVK245BK	CVK246BK
Max. Holding Torque	N·m	0.2	0.37	0.35	0.48	0.58	0.93
Holding Torque at Motor Standstill	N·m	0.1	0.19	0.18	0.24	0.29	0.47
Rotor Inertia	J: kg·m ²	24×10 ⁻⁷	50×10 ⁻⁷	36×10 ⁻⁷	57×10 ⁻⁷	83×10 ⁻⁷	114×10 ⁻⁷
Rated Current	A/Phase	2.3					
Basic Step Angle		1.8°					
Power-Supply Voltage		24 VDC±10% 2.0 A					
Excitation Mode		Microstep					

● A 0.6 m connection cable is included.

Speed - Torque Characteristics

CVK233AK/CVK233BK

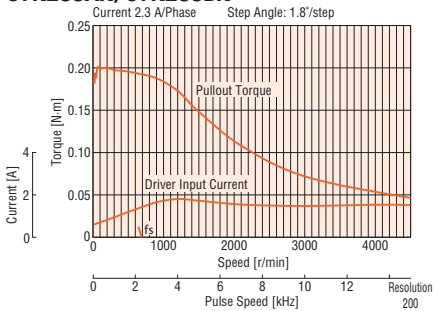

CVK235AK/CVK235BK

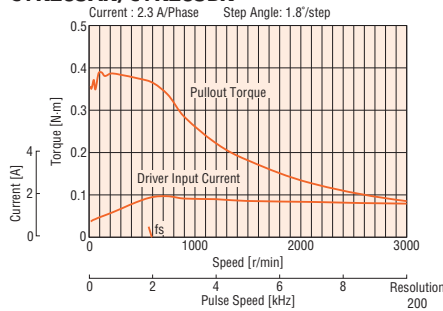

CVK243AK/CVK243BK

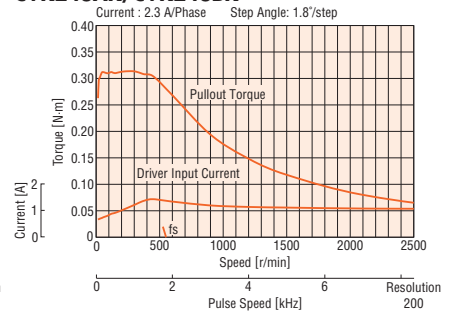

CVK244AK/CVK244BK

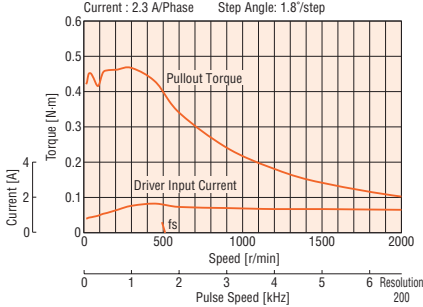

CVK245AK/CVK245BK

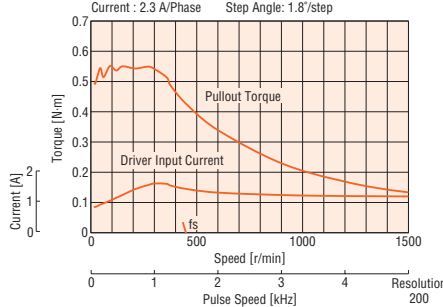

CVK246AK/CVK246BK

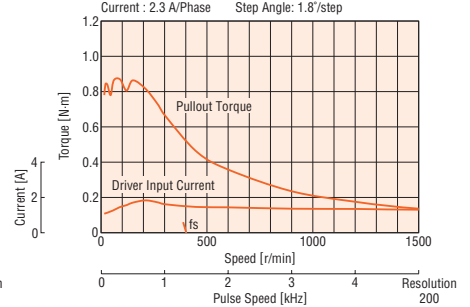

● The pulse input circuit responds up to 1 MHz with a pulse duty of 50%.

Note

● Depending on the driving conditions, a considerable amount of heat may be generated by the motor. Be sure to keep the motor case temperature under 100°C.

Dimensions Unit = mm

Product Name	Motor Product Name	L1	L2	Mass kg
CVK233AK	PKP233D23A	37	-	0.18
CVK233BK	PKP233D23B		52	
CVK235AK	PKP235D23A	52	-	0.285
CVK235BK	PKP235D23B		67	

● A 0.6 m motor connection cable is included with each package : **LC2B06B**

● Motor Applicable Connector

Connector Housing: 51103-0600 (Molex)

Contact: 50351-8100 (Molex)

Crimp Tool: 63811-8100 (Molex)

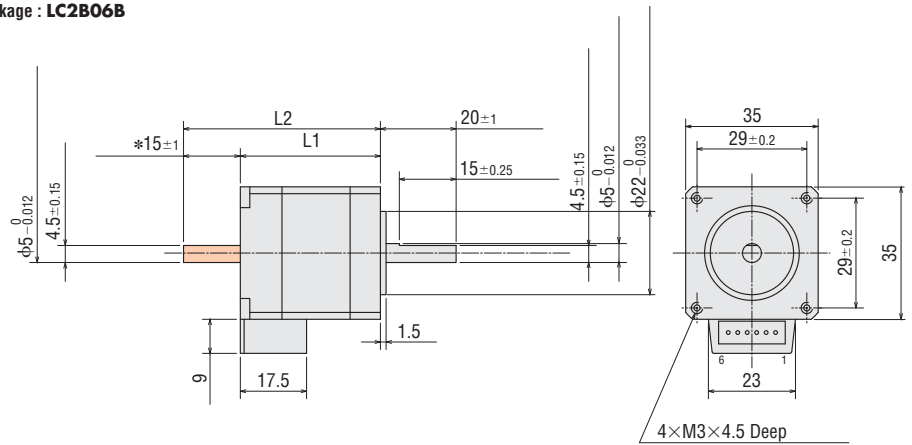

* The length of machining on the double shaft product is $15_{\pm 0.25}$.

● These dimensions are for double shaft products. For single shaft products, ignore the  areas.

Product Name	Motor Product Name	L1	L2	Mass kg
CVK243AK	PKP243D23A	33	-	0.25
CVK243BK	PKP243D23B		48	
CVK244AK	PKP244D23A	39	-	0.3
CVK244BK	PKP244D23B		54	
CVK245AK	PKP245D23A	47	-	0.39
CVK245BK	PKP245D23B		62	
CVK246AK	PKP246D23A	59	-	0.5
CVK246BK	PKP246D23B		74	

● A 0.6 m motor connection cable is included with each package : **LC2B06B**

● Applicable Connector

Connector Housing: 51065-0600 (Molex)

Contact: 50212-8100 (Molex)

Crimp Tool: 63819-0500 (Molex)

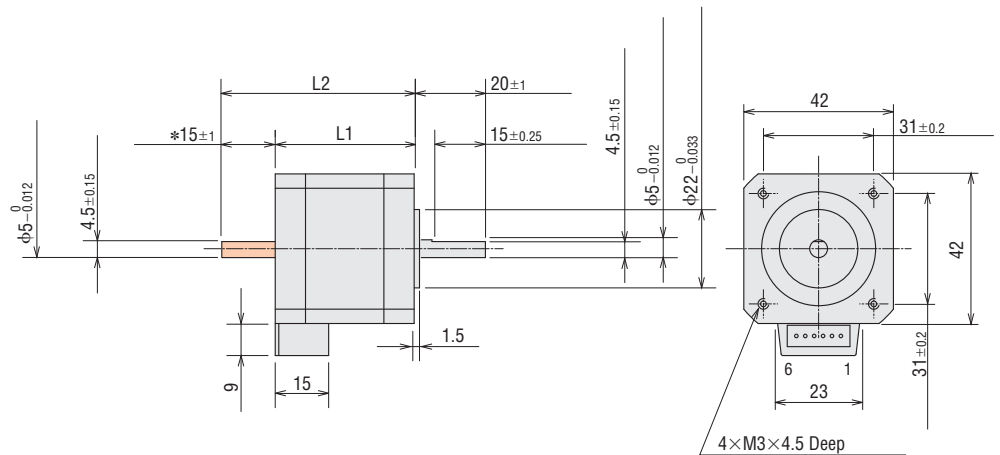

* The length of machining on the double shaft product is $15_{\pm 0.25}$.

● These dimensions are for double shaft products.
For single shaft products, ignore the  areas.

0.72°/0.36° Stepper Motor and Driver Package

Frame Size: 42 mm

Standard / High Resolution Type

Specifications



Product Name	Single Shaft	CVK544AK	CVK546AK	CVK544MAK	CVK546MAK
	Double Shaft	CVK544BK	CVK546BK	CVK544MBK	CVK546MBK
Max. Holding Torque	N·m	0.26	0.44	0.26	0.44
Holding Torque at Motor Standstill	N·m	0.13	0.22	0.13	0.22
Rotor Inertia	J: kg·m ²	57×10^{-7}	114×10^{-7}	60×10^{-7}	121×10^{-7}
Rated Current	A/Phase	1.8			
Basic Step Angle		0.72°		0.36°	
Power-Supply Voltage		24 VDC ± 10% 2.8 A			
Excitation Mode		Microstep			

● A 0.6 m connection cable is included.

Speed - Torque Characteristics

CVK544AK/CVK544BK

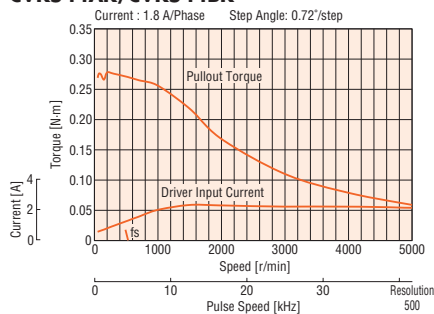

CVK546AK/CVK546BK

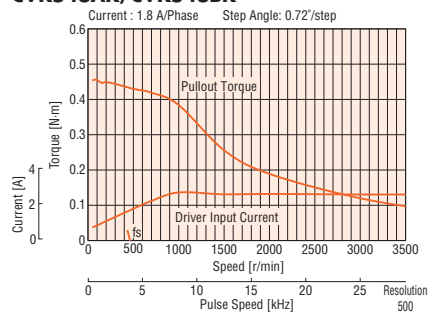

CVK544MAK/CVK544MBK

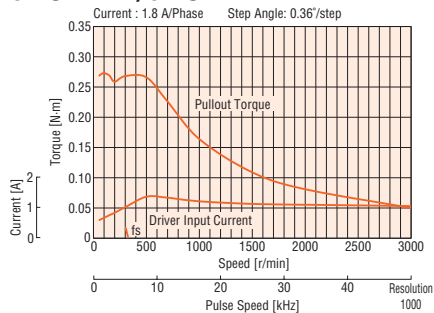

CVK546MAK/CVK546MBK

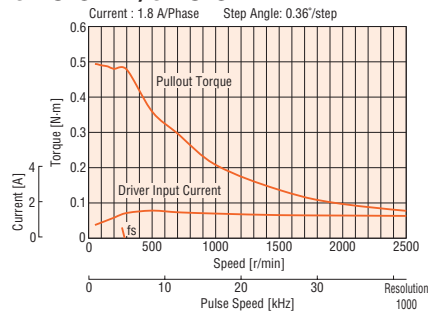

● The pulse input circuit responds up to 1 MHz with a pulse duty of 50%.

Note

● Depending on the driving conditions, a considerable amount of heat may be generated by the motor. Be sure to keep the motor case temperature under 100°C.

Dimensions Unit = mm

Product Name	Motor Product Name	L1	L2	Mass kg
CVK544 □ AK	PKP544□N18A	39	—	0.3
CVK544 □ BK	PKP544□N18B		54	
CVK546 □ AK	PKP546□N18A	59	—	0.5
CVK546 □ BK	PKP546□N18B		74	

- A 0.6 m motor connection cable is included with each package : **LC5N06B**
- Enter **M** in the box (□) within the product name for 0.36° high resolution type
- Applicable Connector
 Connector housing: 51103-0500 (Molex)
 Contact: 50351-8100 (Molex)
 Crimp tool: 57295-5000 (Molex)

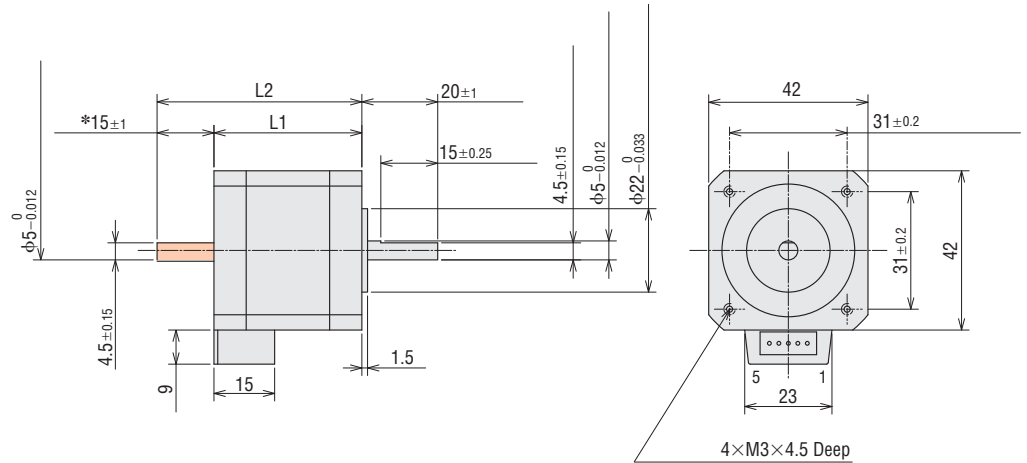

* The length of machining on the double shaft product is $15_{\pm 0.25}$.

1.8° Stepper Motor and Driver Package

Frame Size: 56.4 mm

Standard Type

Specifications



Product Name	Single Shaft	CVK264AK	CVK266AK	CVK268AK
	Double Shaft	CVK264BK	CVK266BK	CVK268BK
Max. Holding Torque	N·m	0.6	1.4	2.3
Holding Torque at Motor Standstill	N·m	0.3	0.7	1.15
Rotor Inertia	J: kg·m ²	120×10 ⁻⁷	290×10 ⁻⁷	490×10 ⁻⁷
Rated Current	A/Phase	2.8		
Basic Step Angle		1.8°		
Power-Supply Voltage		24 VDC±10% 2.5 A		
Excitation Mode		Microstep		

● A 0.6 m connection cable is included.

Speed - Torque Characteristics

CVK264AK/CVK264BK

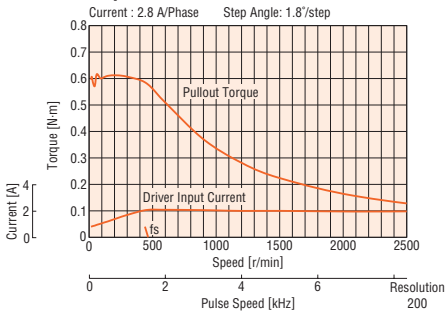

CVK266AK/CVK266BK

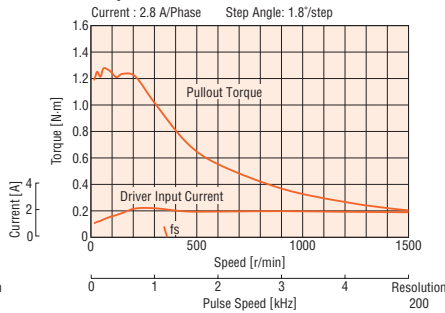

CVK268AK/CVK268BK

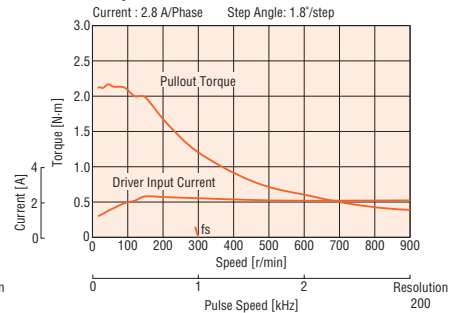

● The pulse input circuit responds up to 1 MHz with a pulse duty of 50%.

Note

● Depending on the driving conditions, a considerable amount of heat may be generated by the motor. Be sure to keep the motor case temperature under 100°C.

Dimensions Unit = mm

- $\phi 8$ mm front shaft

Product Name	Motor Product Name	L1	L2	Mass kg
CVK264AK	PKP264D28A	39	-	0.46
CVK264BK	PKP264D28B		62	
CVK266AK	PKP266D28A	54	-	0.73
CVK266BK	PKP266D28B		77	
CVK268AK	PKP268D28A	76	-	1.1
CVK268BK	PKP268D28B		99	

- A 0.6 m motor connection cable is included with each package : **LC2B06B**

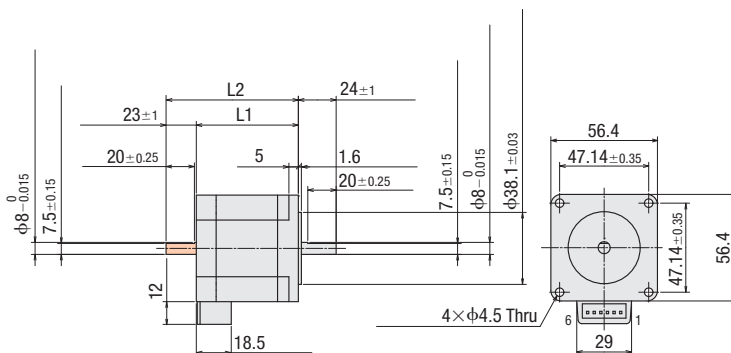



- $\phi 6.35$ mm front shaft

Order driver and motor separately (No package)

Motor Product Name	Driver Product Name	L1	L2	Mass kg
PKP264D28AA-L	CVD228-K	39	-	0.46
PKP264D28BA-L			55	
PKP266D28AA-L		54	-	0.73
PKP266D28BA-L			70	
PKP268D28AA-L		76	-	1.1
PKP268D28BA-L			92	

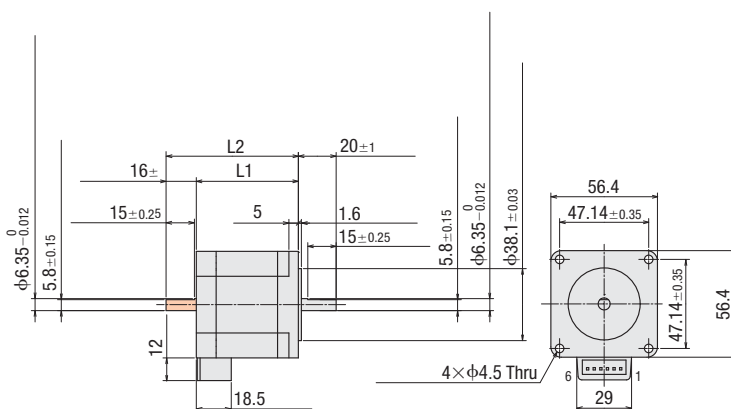
- A 0.6 m motor connection cable is included with motor: **LC2B06B**



- These dimensions are for double shaft products. For single shaft products, ignore the  areas.

0.72°/0.36° Stepper Motor and Driver Package

Frame Size: 60 mm

Standard / High Resolution Type

Specifications



Product Name	Single Shaft	CVK564FAK	CVK566FAK	CVK569FAK	CVK564FMAK*	CVK566FMAK*	CVK569FMAK*
	Double Shaft	CVK564FBK	CVK566FBK	CVK569FBK	CVK564FMBK*	CVK566FMBK*	CVK569FMBK*
Max. Holding Torque	N·m	0.55	0.95	1.7	0.78	1.25	2.3
Holding Torque at Motor Standstill	N·m	0.28	0.48	0.85	0.39	0.63	1.15
Rotor Inertia	J: kg·m ²	175×10 ⁻⁷	280×10 ⁻⁷	560×10 ⁻⁷	310×10 ⁻⁷	490×10 ⁻⁷	970×10 ⁻⁷
Rated Current	A/Phase	2.4					
Basic Step Angle		0.72°			0.36°		
Power-Supply Voltage		24 VDC±10% 2.7 A					
Excitation Mode		Microstep					

*A 0.6 m connection cable is included with a connector-coupled motor.

Speed - Torque Characteristics

CVK564FAK/CVK564FBK

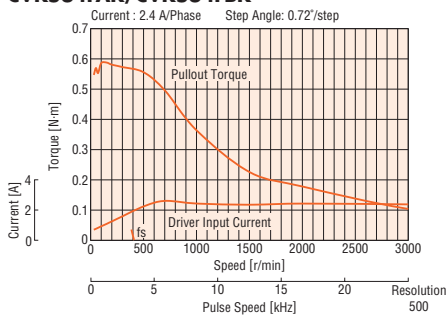

CVK566FAK/CVK566FBK

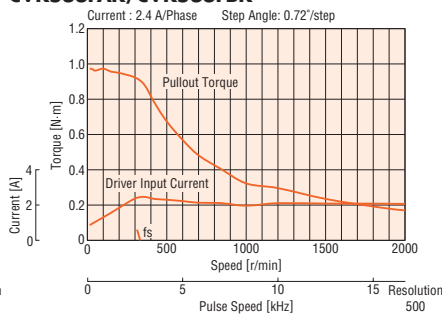

CVK569FAK/CVK569FBK

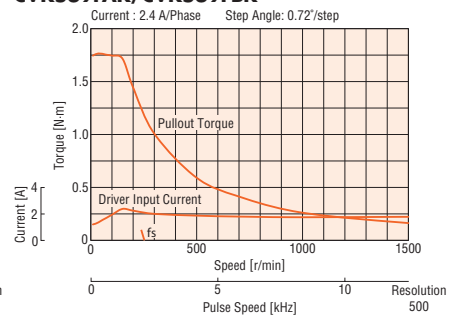

CVK564FMAK/CVK564FMBK

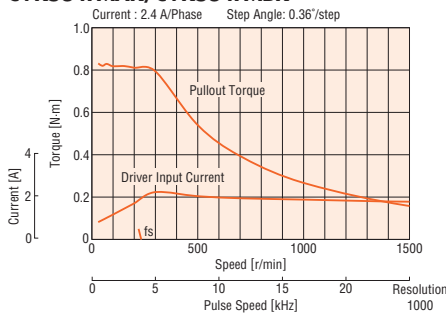

CVK566FMAK/CVK566FMBK

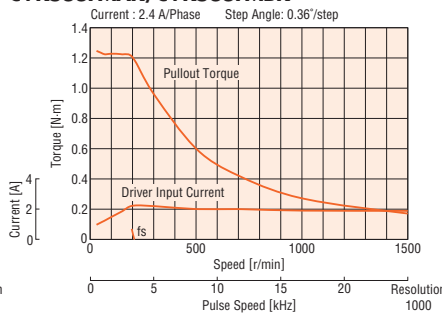

CVK569FMAK/CVK569FMBK

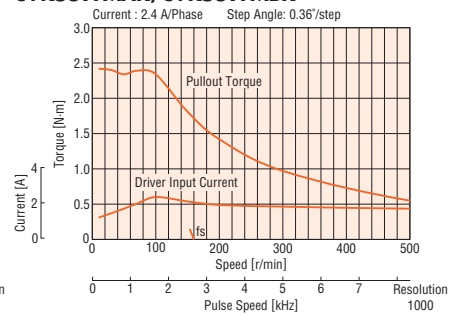

● The pulse input circuit responds up to 1 MHz with a pulse duty of 50%.

Note

● Depending on the driving conditions, a considerable amount of heat may be generated by the motor. Be sure to keep the motor case temperature under 100°C.

Dimensions Unit = mm

Product Name	Motor Product Name	L1	L2	Mass kg
CVK564FAK	PKP564FN24AW	46.5	—	0.6
CVK564FBK	PKP564FN24BW		69.5	
CVK566FAK	PKP566FN24AW	57.5	—	0.8
CVK566FBK	PKP566FN24BW		80.5	
CVK569FAK	PKP569FN24AW	87	—	1.3
CVK569FBK	PKP569FN24BW		110	

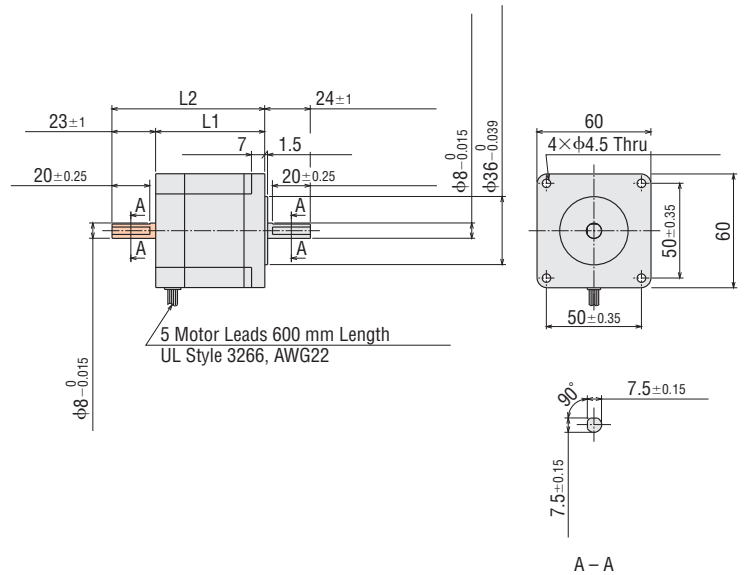

Product Name	Motor Product Name	L1	L2	L3	ϕD	Mass kg
CVK564FMAK	PKP564FMN24A	46.5	—	7.5 ± 0.15	$8 - 0.015$	0.65
CVK564FMBK	PKP564FMN24B		69.5			
CVK566FMAK	PKP566FMN24A	56	—	7.5 ± 0.15	$8 - 0.015$	0.87
CVK566FMBK	PKP566FMN24B		79			
CVK569FMAK	PKP569FMN24A	87	—	9.5 ± 0.15	$10 - 0.015$	1.5
CVK569FMBK	PKP569FMN24B		110			

● A 0.6 m motor connection cable is included with each package : **LC5N06C**

● Applicable Connector

Connector housing: 51144-0500 (Molex)

Contact: 50539-8100 (Molex)

Crimp tool: 57189-5000 (Molex)

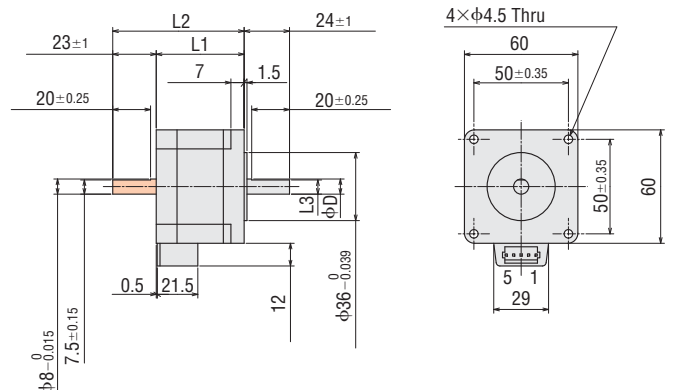

Driver Specifications

Max. Input Pulse Frequency	Line driver output by programmable controller: 1 MHz (When the pulse duty is 50%) Open-collector output by programmable controller: 250 kHz (When the pulse duty is 50%) Negative logic pulse input
Input Signal	Photocoupler input, input current 5~15 mA, input voltage, 3~5.25 VDC (CW (PLS), CCW (DIR.)) Photocoupler input, input current 5~15 mA, input voltage, 4.5~5.25 VDC (AWO, CS)
Output Signal	Photocoupler/Open-collector output External use conditions: 30 VDC 10 mA max. (ALM, TIM)

General Specifications

	Motor	Driver
Heat-Resistant Class	130 (B)	—
Insulation Resistance	In normal ambient temperature and humidity, the value measured using a 500 VDC megger between the windings and the case is 100 MΩ or higher.	—
Dielectric Strength	In normal ambient temperature and humidity, applying voltage between the windings and the case for one minute under the following conditions does not result in abnormalities. <ul style="list-style-type: none"> PKP213, PKP22□, PKP23□, PKP24□, PKP52□, PKP54□: 0.5 kV 50/60 Hz PKP26□: 1.0 kV 50/60 Hz PKP56□: 1.5 kV 50/60 Hz 	—
Operating Environment (In operation)	Ambient Temperature	−10~+50°C (non-freezing)
	Ambient Humidity	85% max. (non-condensing)
	Atmosphere	Use in an area without corrosive gases and dust. The product should not be exposed to water, oil or other liquids.
Temperature Rise	Winding temperature rise is 80°C or less. (Based on in-house measurement conditions)	—
Stop Positioning Accuracy*1	Standard type: ±3 minutes (±0.05°) [For PKP213, it is ±5 minutes (±0.083°)] High-resolution type: ±2 minutes (±0.034°)	—
Shaft Runout	0.05 mm T.I.R.*4	—
Radial Play*2	0.025 mm Max. Load 5 N	—
Axial Play*3	0.075 mm Max. Load 10 N [For PKP213, the load is 1 N]	—
Concentricity of Installation Pilot to the Shaft	0.075 mm T.I.R.*4	—
Perpendicularity of Installation Surface to the Shaft	0.075 mm T.I.R.*4	—

*1 This value is for full step under no load. (The value changes with the size of the load.)

*2 Radial Play: Displacement in shaft position in the radial direction when a 5 N load is applied in the vertical direction to the tip of the motor shaft.

*3 Axial Play: Displacement in shaft position in the axial direction when a 10 N load [1N in PKP213] is applied to the motor shaft in the axial direction.

*4 T.I.R. (Total Indicator Reading): The total dial gauge reading when the measurement section is rotated one revolution centered on the reference axis center.

Note

● Do not measure insulation resistance or perform a dielectric strength test while the motor and driver are connected.

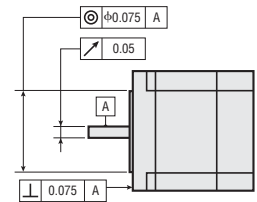

Permissible Radial Load and Permissible Axial Load

Unit = N

Type	Motor Frame Size	Motor Product Name	Permissible Radial Load					Permissible Axial Load
			Distance from Shaft End in mm					
			0	5	10	15	20	
Standard Type	20 mm	PKP213	12	15	—	—	—	Motor's self-weight max.
	28 mm	PKP223, PKP225 PKP523, PKP525	25	34	52	—	—	
	35 mm	PKP233 PKP235	20	25	34	52	—	
	42 mm	PKP243 PKP244 PKP245 PKP246 PKP544 PKP546	20	25	34	52	—	
	56.4 mm	PKP264 PKP266 PKP268	61	73	90	110	160	
	60 mm	PKP564 PKP566 PKP569	63	75	95	130	190	
High-Resolution Type	42 mm	PKP544 PKP546	20	25	34	52	—	
	60 mm	PKP564 PKP566 PKP569	90	100	130	180	270	

● **Driver Unit = mm**

Driver Product Name: CVD205-K, CVD215-K, CVD223-K, CVD228-K, CVD512-K, CVD518-K, CVD524-K
 Mass: 0.02 kg

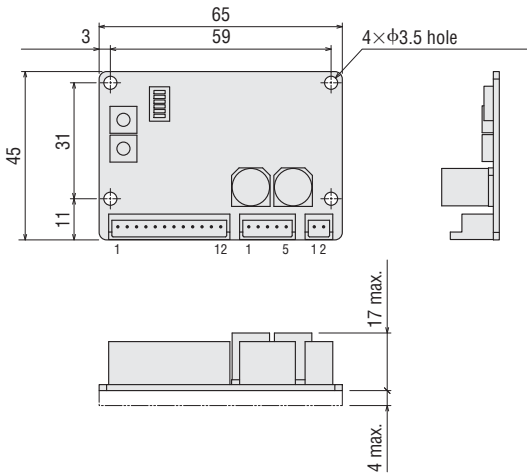

● **Included**

- Connector housing: 51103-0200 (Molex)
- 51103-0500 (Molex)
- 51103-1200 (Molex)
- Connector: 50351-8100 (Molex)

● **Cable for the Motor (Included) Unit = mm**

	Frame Size	Product Name
1.8° Stepper Motor and Driver Package	28 mm	LC2B06A
	35 mm, 42 mm	LC2B06B
	56.4 mm	LC2B06C
0.72°/0.36° Stepper Motor Package	28 mm	LC5N06A
	42 mm	LC5N06B
	60 mm	LC5N06C

Product Name: **LC2B06A**

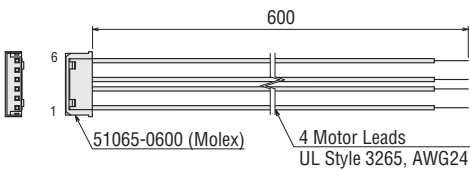

Product Name: **LC2B06B**

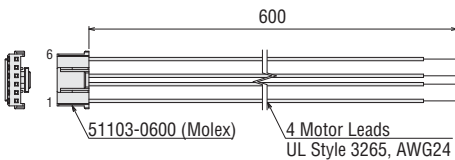

Product Name: **LC2B06C**

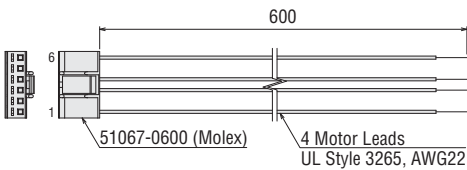

Product Name: **LC5N06A**

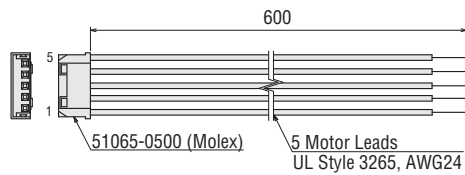

Product Name: **LC5N06B**

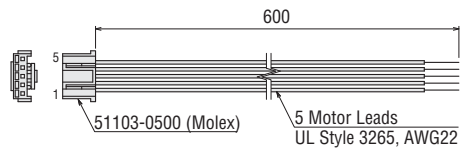

Product Name: **LC5N06C**

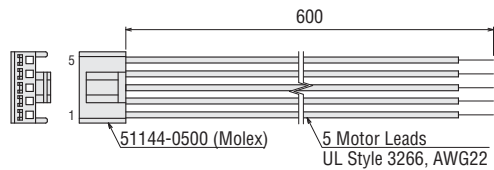

● **Information on Applicable Connectors Unit = mm**

The applicable connectors for motors are shown in the table below.

	Frame Size	Connector Housing (Molex)	Contact (Molex)	Crimp Tool (Molex)
1.8° Stepper Motor and Driver Package	28 mm	51065-0600	50212-8100	57176-5000
	35 mm, 42 mm	51103-0600	50351-8100	57295-5000
	56.4 mm	51067-0600	50217-9101	57189-5000 57190-5000
0.72°/0.36° Stepper Motor and Driver Package	28 mm	51065-0500	50212-8100	57176-5000
	42 mm	51103-0500	50351-8100	57295-5000
	60 mm	51144-0500	50539-8100	57189-5000

Connection and Operation

Names and Functions of Driver Parts

1 Signal Monitor Display

LED Indicator

Indication	Color	Function	Lighting Condition
PWR/ALM	Green	Power supply indicator	When the power supply is input
	Red	Alarm indication	Blinks when protective function is activated

Alarm Details

Blink Count	Function	Operating Condition
2	Overheat protection	The temperature of a driver's substrate has reached 85°C
3	Overvoltage protection	The power supply voltage has exceeded the permissible value Large inertial load came to a sudden stop Large load has been raised and/or lowered
5	Overcurrent protection	Activated when an excessive current flows through the motor's output circuit
9	EEPROM abnormality	The saved data for the driver has been damaged
Lighting	CPU abnormality	The driver's CPU has malfunctioned

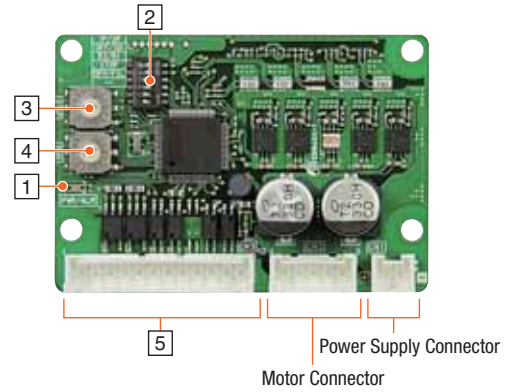

2 Function Switch

Indication	No.	Function
1P/2P	1	Switches the pulse input mode between 1-pulse input mode and 2-pulse input mode.
OFF/SD	2	Enables and disables the smooth drive function.
R2/R1	3	Sets the step angle in combination with the step angle setting switch
STOP	4	Switches the motor's standstill current between 25% and 50%.
OFF/FIL	5	Enables and disables the reference filter function.
—	6	Not used.

OFF/FIL Reference filter function

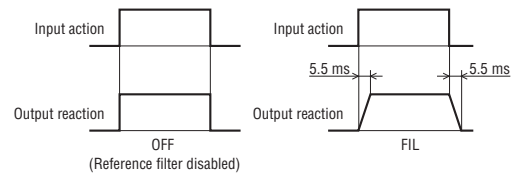

3 Step Angle Setting Switch

Indication	Function
STEP	Sets the motor's step angle in combination with the R2/R1 switch.

Step Angle Setting Switch (STEP) Scale	R2/R1 Switch: When Turned ON (R1)		R2/R1 Switch: When Turned OFF (R2)	
	Resolution (P/R)	Step Angle	Resolution (P/R)	Step Angle
0	500	0.72°	200	1.8°
1	1000	0.36°	400	0.9°
2	1250	0.288°	800	0.45°
3	2000	0.18°	1000	0.36°
4	2500	0.144°	1600	0.225°
5	4000	0.09°	2000	0.18°
6	5000	0.072°	3200	0.1125°
7	10000	0.036°	5000	0.072°
8	12500	0.0288°	6400	0.05625°
9	20000	0.018°	10000	0.036°
A	25000	0.0144°	12800	0.028125°
B	40000	0.009°	20000	0.018°
C	50000	0.0072°	25000	0.0144°
D	62500	0.00576°	25600	0.0140625°
E	100000	0.0036°	50000	0.0072°
F	125000	0.00288°	51200	0.00703125°

Compared to standard types, high-resolution types have twice the resolution and half of the step angle.

Example: When the R2/R1 switch is ON (R1) and the STEP switch is "0"

Resolution of high-resolution types: $500 \times 2 = 1000$

Step angle of high-resolution types: $0.72^\circ / 2 = 0.36^\circ$

4 Operation Current Setting Switch

Indication	Function
RUN	Sets the motor's operating current.

5 I/O Signal Connector

Indication	Pin No.	I/O	Signal Name	Function
CN3	1	Input	CW+ (PLS+)	Motor will rotate in the CW direction.
	2		CW- (PLS-)	(Operation command pulse signal when 1-pulse input mode is used)
	3		CCW+ (DIR.+)	Motor will rotate in the CCW direction.
	4		CCW- (DIR.-)	(Rotation direction signal when 1-pulse input mode is used)
	5		AWO+	Switches the motor into its non-excitation state.
	6		AWO-	
	7		CS+	Switches the step angle.
	8		CS-	
	9	Output	ALM+	Output the alarm status for the driver (Normally closed contact)
	10		ALM-	
	11		TIM+	Motor's excitation state is output at step "0."
	12		TIM-	

Connection Diagram

When the Pulse Input is the Line Driver

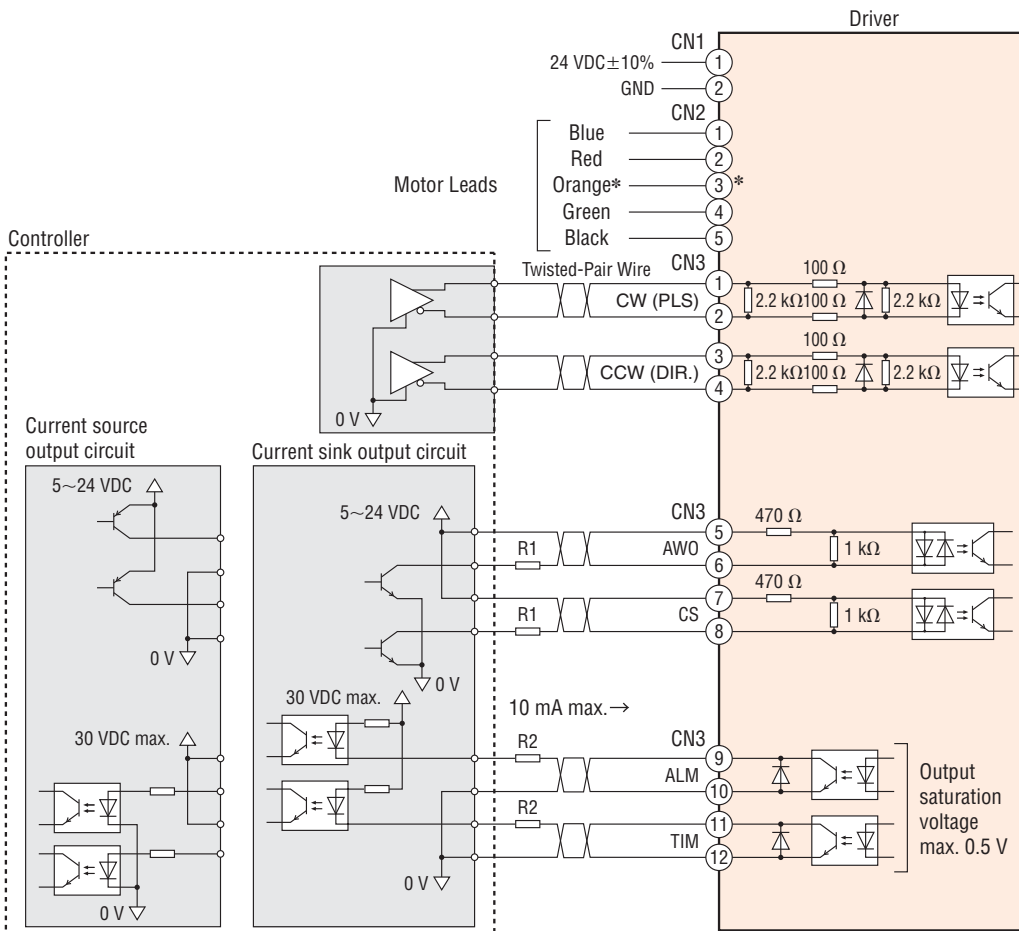

* Not available on a 1.8° stepper motor. Do not connect anything to Pin No.3.

When the Pulse Input is the Open Collector

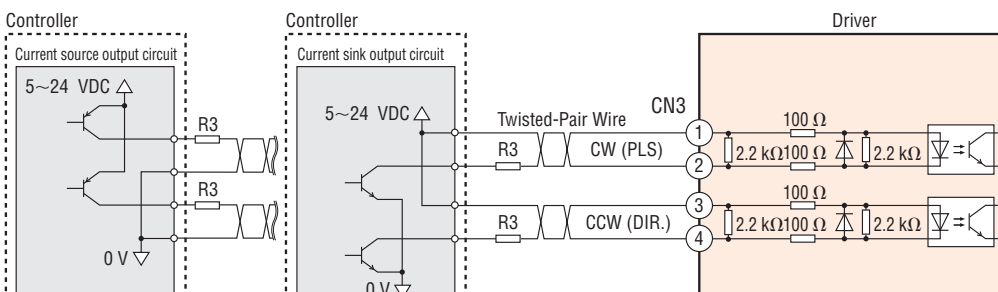

[Note on Wiring]

◇ I/O Signal Connection

● Input signal

Use 5 VDC for input signal.

When applying a voltage that exceeds 5 VDC, connect an external resistor R1 so that the current is between 5~15 mA. (AWO, CS)

When the pulse is input by an open collector and a voltage that exceeds 5 VDC for CW input and CCW input is going to be applied, connect an external resistor R3 so that the current is between 7~20 mA.

● Output signal

For output signal, please use 30 VDC, 10 mA or less. When the current value exceeds 10 mA, please connect an external resistor R2.

● Use a twisted-pair wire AWG24~22 (0.2~0.3 mm²).

● Since the maximum transmissible frequency drops as the pulse line becomes longer, keep the wiring length as short as possible within 2 m.

● Provide a distance of 100 mm min. between the I/O signal lines and power lines (power supply lines, motor lines, etc.).

◇ Power Supply Connection

● Use AWG22 (0.3 mm²) wires.

● Incorrect polarities of the DC power-supply input will lead to driver damage. Make sure that the polarity is correct before turning the power on.

◇ Extension of Motor Cable

● Use AWG22 (0.3 mm²) or thicker wires.

◇ General

● A separate hand crimp tool is required to crimp the supplied power connector included and lead wire. Accessory connection cables (sold separately) are crimped lead wires.

● If noise generated by the motor cable or power supply cable causes a problem with the specific wiring or layout, shield the cable or use ferrite cores.

Motor and Driver Combinations

The product names for motor and driver combinations are shown below.

1.8° Stepper Motor and Driver Package

Type	Product Name	Motor Product Name	Driver Product Name
Standard Type	CVK213 □K	PKP213D05□	CVD205-K
	CVK223 □K	PKP223D15□2*	CVD215-K
	CVK225 □K	PKP225D15□2*	
	CVK233 □K	PKP233D23□*	CVD223-K
	CVK235 □K	PKP235D23□*	
	CVK243 □K	PKP243D23□*	
	CVK244 □K	PKP244D23□*	
	CVK245 □K	PKP245D23□*	
	CVK246 □K	PKP246D23□*	CVD228-K
	CVK264 □K	PKP264D28□*	
CVK266 □K	PKP266D28□*		
CVK268 □K	PKP268D28□*		

Type	Product Name	Motor Product Name	Driver Name
Standard	CVD228-K / PKP264D28 □A-L	PKP264D28□A	CVD228-K
	CVD228-K / PKP266D28 □A-L	PKP266D28□A	
	CVD228-K / PKP268D28 □A-L	PKP268D28□A	

● Front motor shaft is $\phi 6.35$ mm

0.72°/0.36° Stepper Motor and Driver Package

Type	Product Name	Motor Product Name	Driver Product Name
Standard Type	CVK523 □K	PKP523N12□*	CVD512-K
	CVK525 □K	PKP525N12□*	
	CVK544 □K	PKP544N18□*	CVD518-K
	CVK546 □K	PKP546N18□*	
	CVK564F □K	PKP564FN24□W	CVD524-K
	CVK566F □K	PKP566FN24□W	
CVK569F □K	PKP569FN24□W		
High-resolution Type	CVK544M □K	PKP544MN18□*	CVD518-K
	CVK546M □K	PKP546MN18□*	
	CVK564FM □K	PKP564FMN24□*	CVD524-K
	CVK566FM □K	PKP566FMN24□*	
	CVK569FM □K	PKP569FMN24□*	

● The □ contains either **A** (single shaft) or **B** (double shaft) to indicate the configuration.

* Connection cables and connectors are not included when only a motor is purchased for maintenance, etc. They must be purchased separately.

Accessories

For more information, please check our website - www.orientalmotor.eu - or contact our customer center.

Flexible Coupling RoHS



Coupling Selection Table

Type	Applicable Product		Coupling Type	Motor Shaft Diameter mm	Driven Shaft Diameter mm							
	Motor Frame Size	Applicable Motor			04	05	06	F04	08	10	12	
					$\phi 4$	$\phi 5$	$\phi 6$	$\phi 6.35$	$\phi 8$	$\phi 10$	$\phi 12$	
High-Torque Type	20 mm	PKP213	MCS14	04	$\phi 4$	●	●	●				
	28 mm	PKP223 PKP523 PKP225 PKP525	MCS14	05	$\phi 5$	●	●	●				
		35 mm	PKP233 PKP235	MCS14	05	$\phi 5$	●	●	●			
	42 mm		PKP243 PKP244 PKP544	MCS14	05	$\phi 5$	●	●	●			
		56.4 mm	PKP246 PKP546	MCS20	05	$\phi 5$		●	●	●	●	●
	56.4 mm		PKP264 *	MCS20	F04	$\phi 6.35$		●	●	●	●	●
		60 mm	PKP266 *	MCS30	F04	$\phi 6.35$		●	●	●	●	●
	PKP268 *						●	●	●	●	●	
	60 mm	PKP564 PKP566	MCS20	08	$\phi 8$		●	●	●	●	●	
			PKP569	MCS30	08	$\phi 8$		●	●	●	●	●

● The applicable motor products are listed such that the coupling can be determined.

● These couplings can also be used with a motor with an encoder.

* For 8 mm front motor shaft, use **MCS2008**.

Cable

● Cable System Configuration

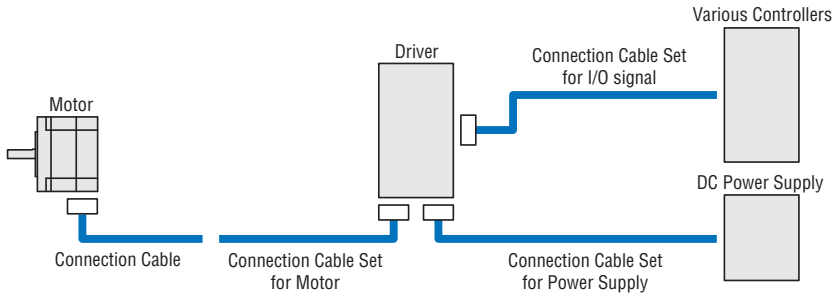

■ Connection Cable Sets



These are lead wires that come with connectors for the driver. They make connecting the motor, power supply, and I/O signal components easy. A connection cable set includes cables for the motor, cables for the power supply, and cables for the I/O signal.

■ Connection Cables

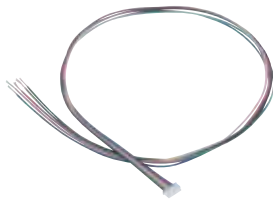

These crimped lead wire-type connection cables are convenient for connecting connector-coupled motors. Because they are already crimped, they eliminate the need for assembly. A 0.6 m connection cable is included in connector-coupled motor and driver packages.

● Product Line and List Price

Product Name	Applicable Drivers	Length m	Conductor AWG
LCS01CVK2	CVD205-K	0.6	22 (0.3 mm ²)
	CVD215-K		
	CVD223-K		
	CVD228-K		
LCS04SD5	CVD512-K	0.6	22 (0.3 mm ²)
	CVD518-K		
	CVD524-K		

● Product Line and List Price

Product Name	Applicable Motor	Length m	Conductor AWG
LC2B06A	PKP223	0.6	24 (0.2 mm ²)
	PKP225		
LC2B06B	PKP233	0.6	24 (0.2 mm ²)
	PKP235		
	PKP243		
	PKP244		
	PKP245		
	PKP246		
LC2B06C	PKP264	0.6	22 (0.3 mm ²)
	PKP266		
	PKP268		
LC5N06A	PKP523	0.6	24 (0.2 mm ²)
LC5N10A	PKP525	1	
LC5N06B	PKP544	0.6	22 (0.3 mm ²)
LC5N10B	PKP546	1	
LC5N06C	PKP564	0.6	22 (0.3 mm ²)
	PKP566		
LC5N10C	PKP569	1	

● The applicable motor products are listed such that the motor can be determined.

Motor Mounting Bracket



Mounting brackets are convenient for installation and securing a stepper motor.

● Product Line and List Price

Material: Aluminum alloy

Product Name	Motor Frame Size	Applicable Product
PAFOP	42 mm	CVK24
PALOP		CVK54
PAL2P-2	56.4 mm	CVK26
PAL2P-5	60 mm	CVK56

- Names of applicable products contain characters that make product names identifiable.
- The mounting bracket base is built with holes large enough to allow for adjustments of belt tension after the motor is installed.
- These mounting brackets can fit to the pilot of the stepper motors. (Excluding **PALOP**)

Controller

Universal Controller

SCX11 (RoHS)

The **SCX11** Universal Controller is a highly functional and sophisticated controller, equipped with program editing and execution functions. The **SCX11** is also able to control the motor via various serial ports such as USB, RS-232C and **CANopen**. Use the **SCX11** to support Oriental Motor's Pulse Input Type drivers.



Product Line

Product Name
SCX11

Features

- 100 Sequence Programs can be Stored
- Stored Program with GUI
- USB Connection to PC
- Various Interfaces for Operation
- External Encoder Input
- Stand Alone Operation Using Sensors and Switches

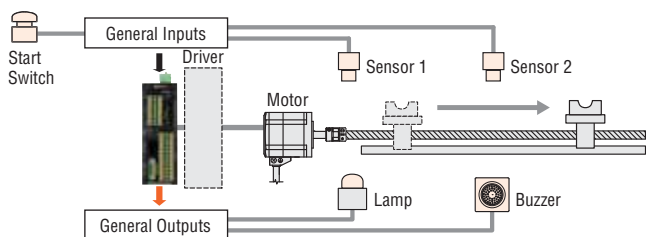

Various Interfaces for Operation

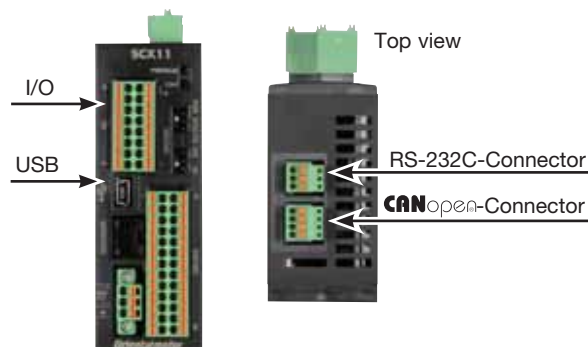

- Direct Command Operation via CANopen
- Operations Using a PC or PLC

These products are manufactured at plants certified with the international standards **ISO 9001** (for quality assurance) and **ISO 14001** (for systems of environmental management).

Specifications are subject to change without notice.
Published in March 2015.

Orientalmotor

ORIENTAL MOTOR (EUROPA) GmbH

www.orientalmotor.de

European Headquarters

Schiesstraße 74
40549 Düsseldorf, Germany
Tel: 0211-5206700 Fax: 0211-52067099



Other countries:

www.orientalmotor.eu



ORIENTAL MOTOR (UK) LTD.

www.oriental-motor.co.uk

UK Headquarters

Unit 5, Faraday Office Park,
Rankine Road, Basingstoke,
Hampshire RG24 8AH, U.K.
Tel: 01256-347090 Fax: 01256-347099



ORIENTAL MOTOR (FRANCE) SARL

www.orientalmotor.fr

France Headquarters

56, Rue des Hautes Pâtures
92000 Nanterre Cedex, France
Tel: 01 47 86 97 50 Fax: 01 47 82 45 16



ORIENTAL MOTOR ITALIA s.r.l.

www.orientalmotor.it

Italy Headquarters

Via A. De Gasperi, 85
20017 Mazzo di Rho (MI), Italy
Tel: 02-93906346 Fax: 02-93906348



ORIENTAL MOTOR CO., LTD.

www.orientalmotor.co.jp

Headquarters

4-8-1 Higashiueno
Taito-ku, Tokyo 110-8536, Japan
Tel: (03)6744-0361 Fax: (03)5826-2576

Customer Center (Support in German & English)

00800-22 55 66 22*
CA LL OM CC

Mon-Thu: 08:00 - 17:30 CET Friday: 08:00 - 16:00 CET

* Free Call Europe

info@orientalmotor.de

For more information please contact: