



Compact motorized cylinder

## **DRS2 Series**

**Actuator**

---

### **OPERATING MANUAL**

#### **Table of contents**

1	Introduction .....	2	8	Maintenance.....	27
2	Safety precautions .....	3	9	Standards and general specifications.....	29
3	Preparation .....	6	10	Troubleshooting and remedial action .....	31
4	Precautions for use.....	8			
5	Installing the guide type .....	10			
6	Installing the non-guide type ..	15			
7	Connection .....	25			

---

Thank you for purchasing an Oriental Motor product.

This Operating Manual describes product handling procedures and safety precautions.

- Please read it thoroughly to ensure safe operation.
- Always keep the manual where it is readily available.

# 1 Introduction

---

## ■ Before use

Only qualified personnel of electrical and mechanical engineering should work with the product.

Use the product correctly after thoroughly reading the section "2 Safety precautions" on p.3. In addition, be sure to observe the contents described in warning, caution, and note in this manual.

The product described in this manual has been designed and manufactured to be incorporated in general industrial equipment. Do not use for any other purpose. Oriental Motor Co., Ltd. is not responsible for any damage caused through failure to observe this warning.

## ■ Operating manuals for the product

Operating manuals for the **DRS2** Series are listed below.

With respect to the operating manual that does not supplied with the product, contact your nearest Oriental Motor sales office or download from Oriental Motor Website Download Page.

Type of operating manual	Description
OPERATING MANUAL Actuator (this document)	This manual explains safety precautions, installation methods, maintenance as well as some parameters of the driver.
OPERATING MANUAL Driver (supplied with the driver)	This manual explains the functions, installation and connection methods for the driver.
Motorized actuator Function Setting Edition *	This manual explains the driver's parameters for when combining actuator.

\* This manual does not come with the product. For details, contact your nearest Oriental Motor sales office or download from Oriental Motor Website Download Page.

## 2 Safety precautions





---

The precautions described below are intended to prevent danger or injury to the user and other personnel through safe, correct use of the product. Use the product only after carefully reading and fully understanding these instructions.



It is prohibited to start operating the actuator (i.e., to operate the device in accordance with the specified purpose) when the machine in which the actuator is incorporated does not satisfy any relevant safety standards. The factory safety manager or safety personnel in charge of the applicable machine must ensure that the machine is operated only by qualified personnel who are familiar with the operation of electronic equipment, and thereby prevent injury or damage to the equipment.

The term "qualified personnel" refers to persons who have received the necessary training or education and have pertinent experience; who are familiar with the relevant standards, regulations, accident-prevention rules and inspection conditions; who are authorized by the factory safety manager to engage in the necessary activities; and who have the ability to discern and prevent potential dangers.

### Description of signs

 <b>WARNING</b>	Handling the product without observing the instructions that accompany a "WARNING" symbol may result in serious injury or death.
 <b>CAUTION</b>	Handling the product without observing the instructions that accompany a "CAUTION" symbol may result in injury or property damage.
 <b>Note</b>	The items under this heading contain important handling instructions that the user should observe to ensure the safe use of the product.
 <b>memo</b>	The items under this heading contain related information and contents to gain a further understanding of the text in this manual.

### Description of graphic symbols

	Indicates "prohibited" actions that must not be performed.
	Indicates "compulsory" actions that must be performed.

## WARNING



- Do not use the product in explosive or corrosive environments, in the presence of flammable gases, locations subjected to splashing water, or near combustibles. Doing so may result in fire, electric shock or injury.
- Do not transport, install the product, perform connections or inspections when the power is on. Doing so may result in electric shock.
- Do not forcibly bend, pull, or pinch the cable. Doing so may result in fire or electric shock.
- Do not disassemble or modify the product. Doing so may result in injury or damage to equipment.
- Never use the product in a medical device used in connection with the maintenance or management of human life or health, or in a transportation system whose purpose is to move or carry people.
- Do not enter the moving range of the actuator while the power is supplied. Be sure to provide a safety cage according to EN ISO13857. Also, when you adjust or inspect while moving the ball screw part by hands, shut down the driver main power supply. Doing so may cause serious injury.
- Do not use the brake mechanism of the electromagnetic brake motor for braking the motor rotation or as a safety brake. Doing so may result in injury or damage to equipment.
- Do not hit the joint of the actuator to the mechanical stopper other than push-motion operation. Doing so may result in injury or damage to equipment.



- Only qualified personnel should be allowed to perform installation, connection, operation and inspection/troubleshooting of the product. Handling by unqualified and uneducated personnel may result in fire, electric shock, injury or equipment damage.
- When setting the data, do so from outside the safety cage. Failure to do so may result in injury.
- Take measures to keep the moving parts in position for vertical operations such as elevator applications. Failure to do so will cause the moving parts to fall and it may result in injury or damage to equipment.
- When the driver generates an alarm (=any of the driver's protective functions is triggered), the actuator will stop and lose its holding torque. Accordingly, provide measures to hold the moving part in place in the event of an alarm. Failure to do so may result in injury or equipment damage.
- Install the product in an enclosure. Failure to do so may result in electric shock or injury.
- Operate the non-guide type actuator after setting the home position. Operating the actuator without setting the home position may cause unexpected movements, leading to injury or damage to equipment.
- Since this product is Class I Equipment, install it so that people cannot have contact with it, or ground it if people may have contact with it. Failure to do so may result in electric shock.

## WARNING



- Provide an emergency stop device or emergency stop circuit externally so that the entire equipment will operate safely in the event of a system failure or malfunction. Failure to do so may result in injury.
- When the driver was replaced, set parameters such as the resolution, moving direction and others before operating the actuator. Operating the actuator without setting parameters may cause the ball screw to move to unexpected directions or run at unexpected speeds, leading to injury or damage to equipment.

## CAUTION



- Do not use the product beyond the specifications. Doing so may result in electric shock, injury or damage to equipment.
- Keep your fingers and objects out of the openings in the product. Doing so may result in fire, electrical shock, or injury.
- Do not touch the product while operating or immediately after stopping. Doing so may result in skin burn(s).
- Do not hold the moving part or cable. Doing so may result in injury.
- Keep the area around the product free of combustible materials. Doing so may result in fire or skin burn(s).
- Do not leave anything around the product that would obstruct ventilation. Doing so may result in damage to equipment.
- Do not touch the moving part during operation. Doing so may result in injury.
- Do not touch the terminals while conducting the insulation resistance measurement or dielectric strength test. This may cause electric shock.
- While operating the actuator, do not make the cable contact with the moving part. Disconnection of the cable may result in electric shock or damage to equipment.



- Use an actuator and driver only in the specified combination. An incorrect combination may cause a fire.
- Dispose the product correctly in accordance with laws and regulations, or instructions of local governments.
- Wear a helmet, safety shoes, gloves or other protective gears when transporting or installing the product. Failure to do so may result in injury.
- Since the motor surface temperature may exceed 70 °C (158 °F) even under normal operating conditions, affix the warning label as shown in the figure in a conspicuous position. Failure to do so may result in skin burn(s).



Warning label

# 3 Preparation

## 3-1 Checking the product

Verify that the items listed below are included. Report any missing or damaged items to the branch or sales office from which you purchased the product.

- Compact motorized cylinder .....1 unit
- OPERATING MANUAL Actuator.....1 copy (this document)

## 3-2 How to identify the actuator model

Verify the model number of the purchased product against the model number shown on the nameplate.

**DRSM 42 R G - 04 A 2 AZ M K**  
 1            2            3            4            5            6            7            8            9            10

1	Series name	<b>DRSM: DRS2 Series</b>
2	Frame size	<b>42:</b> 42 mm (1.65 in.) <b>60:</b> 60 mm (2.36 in.)
3	Cable direction *	<b>R:</b> Right direction <b>L:</b> Left direction Blank: Without a guide
4	Type	<b>G:</b> Guide type Blank: Non-guide type
5	Stroke	<b>04:</b> 40 mm <b>05:</b> 50 mm
6	Ball-screw shaft type	<b>A:</b> Rolled ball screw <b>B:</b> Ground ball screw
7	Ball screw lead	<b>2:</b> 2 mm <b>4:</b> 4 mm <b>8:</b> 8 mm
8	Equipped motor	<b>AZ:</b> AZ Series
9	Electromagnetic brake	<b>A:</b> Without electromagnetic brake <b>M:</b> With electromagnetic brake
10	Motor power supply type	<b>K:</b> DC power input

\* The cable direction can be specified in the guide type actuator. It represents the cable direction viewed from the encoder (ABZO sensor) side with the guide up.

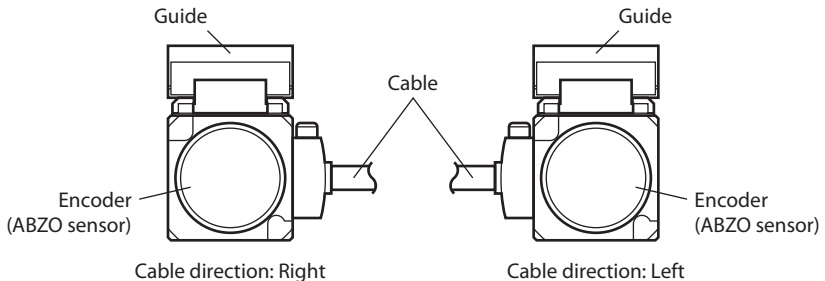

### 3-3 Names of parts

The moving part of the actuator is shown in gray color.

#### ■ Guide type

<b>⚠ CAUTION</b>	
	Do not remove the joint from the ball screw shaft. Doing so may deteriorate the installation accuracy of the ball screw shaft, resulting in malfunction. In addition, if the joint is removed, the home position which has been set in the encoder (ABZO sensor) at the time of shipment may deviate. This may cause unexpected movements of the actuator, leading to damage to equipment.

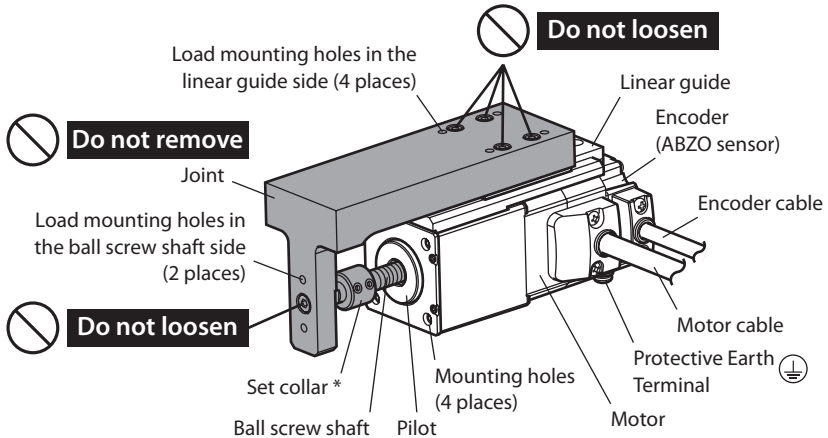

\* It prevents the screw shaft from retracting completely into the case.

#### ■ Non-guide type

The illustration shows an electromagnetic brake type.

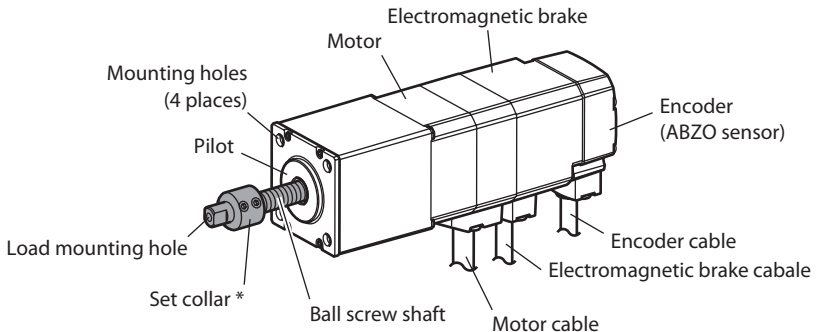

\* It prevents the screw shaft from retracting completely into the case.

# 4 Precautions for use

This section covers limitations and requirements the user should consider when using the product.

## ● General

- Always use an accessory cable to connect the actuator and driver.
- Be sure to provide an anti-spin mechanism for the non-guide type actuator. The actuator cannot be operated without the anti-spin mechanism because the ball screw rotates idly.
- Do not remove the set collar attached to the ball screw shaft. Doing so may result in damage to ball screw shaft.
- Do not remove the joint of the guide type actuator from the ball screw shaft. Doing so may deteriorate the installation accuracy of the ball screw shaft, resulting in malfunction or shorter service life of the actuator. In addition, if the joint is removed, the home position which has been set in the encoder (ABZO sensor) at the time of shipment may deviate. This may cause unexpected movements of the actuator, leading to damage to equipment.
- When conducting the insulation resistance measurement and the dielectric strength test, be sure to separate the connection between the actuator and the driver. Conducting the insulation resistance measurement or dielectric strength test with the actuator and driver connected may result in damage to the product.
- Do not drop the actuator, and do not hit the motor and mechanism sections against other objects. Doing so may cause the positioning accuracy decrease, the motor section damage or the product service life reduction.
- Do not make a strong impact on the encoder (ABZO sensor). Making a strong impact on an encoder (ABZO sensor) may cause the actuator malfunction or damage to the encoder (ABZO sensor). The warning label shown in the right is attached on the motor.
- Do not move the encoder (ABZO sensor) toward a strong magnetic field. A magnetic sensor is built into the encoder (ABZO sensor). If the actuator is installed close to equipment which generates a strong magnetic field, the encoder (ABZO sensor) may break or malfunction. Keep the magnetic flux density on the surface of the encoder (ABZO sensor) so as not to exceed the values in the table.

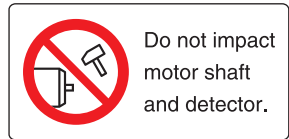

	Magnetic flux density
When operating	10 mT
When transporting and storing	10 mT

- A gear type mechanical sensor is built into the encoder (ABZO sensor). Although the meshing noise of gears may generate, it is not malfunction.
- When you install a carrier guide for load transportation, use the non-guide type actuator. Using the guide type actuator may cause unconformity between guides, leading to damage to equipment.
- When transporting the actuator or installing a load, handle it carefully not to make a strong impact on the moving part.



## ● Temperature

- In order to protect the encoder (ABZO sensor), use the actuator so that the surface temperature on the motor case does not exceed 80 °C (176 °F). If the surface temperature on the motor case may exceed 80 °C (176 °F), improve the operating conditions such as ambient temperature, operating speed, duty cycle and others. If the encoder (ABZO sensor) temperature reaches the upper limit, the motor overheat protection alarm will generate.

## ● Operation

- Operate an actuator in the range of the operating ambient temperature. If the actuator is operated outside the operating ambient temperature, the viscosity of grease may change, causing the thrust force to decrease.
- Keep 20 m (65.6 ft.) or less for the wiring distance between the actuator and driver. Exceeding 20 m (65.6 ft.) may cause the thrust force to decrease.
- The holding torque is decreased by the current cutback function of the driver when the actuator stops. When selecting the actuator, make sure the holding torque at standstill by checking the catalog specification.
- Do not use the electromagnetic brake as a safety brake. To use the electromagnetic brake to hold the load in position, do so after the actuator operation is stopped.
- Do not use the electromagnetic brake as a means to decelerate and stop the actuator. The brake hub of the electromagnetic brake will wear significantly and the braking force will drop. Since the power off activated type electromagnetic brake is equipped, it helps maintain the position of the load when the power is cut off, but this brake cannot securely hold the load in place.
- Do not press the ball screw shaft against a load at the speed exceeding the maximum push speed or the maximum push-motion return-to-home speed. The mechanical impact may cause damage to the actuator. If the ball screw shaft was pressed at high speed, take measures by referring to "10 Troubleshooting and remedial action" on p.31.

## ● Inspection

- Grease on the ball screw shaft may darken within a short time after the start of operation. Refer to "8 Maintenance" on p.27, and wipe off the dirty grease to apply new grease.
- If an abnormal noise (i.e., from deflection or interference) is generated while operating the non-guide type actuator, the installation accuracy may have dropped. Stop the operation and check the installation accuracy of the ball screw shaft.

# 5 Installing the guide type

---

This section explains the installation location, installation method and load mounting method of the guide type actuator.

## 5-1 Installation location

The actuator has been designed and manufactured to be incorporated in general industrial equipment. Install the product in a well-ventilated location that provides easy access for inspection.

- Inside an enclosure that is installed indoors (provide vent holes)
- Operating ambient temperature: 0 to +40 °C [+32 to 104 °F] (non-freezing)
- Operating ambient humidity: 85% or less (non-condensing)
- Area that is free of explosive atmosphere or toxic gas (such as sulfuric gas) or liquid
- Area not exposed to direct sun
- Area free of excessive amount of dust, iron particles or the like
- Area not subject to splashing water (rain, water droplets), oil (oil droplets) or other liquids
- Area free of excessive salt
- Area not subject to continuous vibration or excessive shocks
- Area free of excessive electromagnetic noise (from welders, power machinery, etc.)
- Area free of radioactive materials, magnetic fields or vacuum
- Up to 1000 m (3300 ft.) above sea level

### ■ If a motor is installed in an environment where a magnetic field is generated

A magnetic sensor is built into the encoder (ABZO sensor). If the motor is installed close to equipment which generates a strong magnetic field, the encoder (ABZO sensor) may break or malfunction. Make sure to prevent the magnetic flux density on the surface of the encoder (ABZO sensor) from exceeding 10 mT.



Do not install the motor close to equipment which generates a strong magnetic field.

---

## 5-2 Installation method

The actuator can be installed in any direction.

Install the actuator onto an appropriate metal flat mounting plate [thickness approximately 5 mm (0.2 in.) or more] having excellent vibration resistance and heat conductivity. If a high accuracy is required, design the thickness of the mounting plate in consideration of installation conditions such as load condition, rigidity, vibration, and others.

An accessory mounting plate is provided. Refer to p.12 for the installation method using the accessory mounting plate.

## ■ Details of actuator mounting hole

- Screw size: M4
- Tightening torque: 1.8 N·m (250 oz-in)

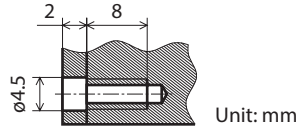

## ■ Component part design

The following shows the recommended design dimension of component part required for when the actuator is installed.

### ● Mounting plate

Perform machining for a through hole of the flange pilot and a clearance groove of the set collar on the mounting plate.

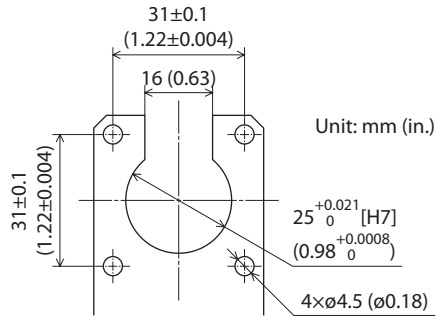

## ■ Installation example

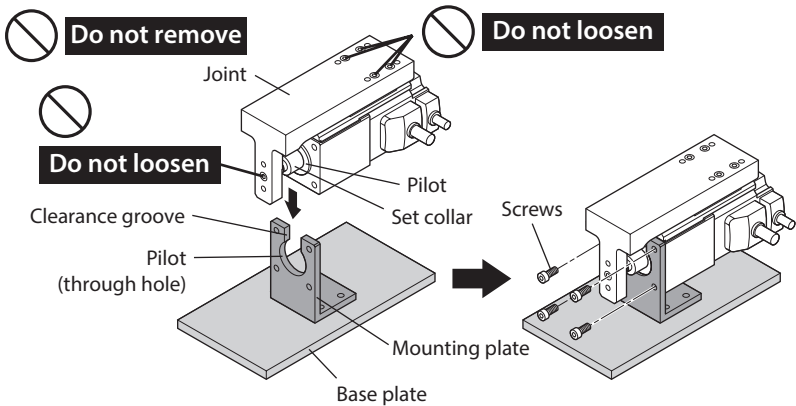

## ⚠ CAUTION



Do not remove the joint from the ball screw shaft. Doing so may deteriorate the installation accuracy of the ball screw shaft, resulting in malfunction. In addition, if the joint is removed, the home position which has been set in the encoder (ABZO sensor) at the time of shipment may deviate. This may cause unexpected movements of the actuator, leading to damage to equipment.

The accessory mounting plate is a dedicated bracket (steel) to install the actuator onto a base plate. Screws to secure the actuator to the mounting plate are provided (M4, 4 pieces).

### ■ Securing the actuator

Secure the actuator to the mounting plate using the supplied screws (M4, 4 pieces).

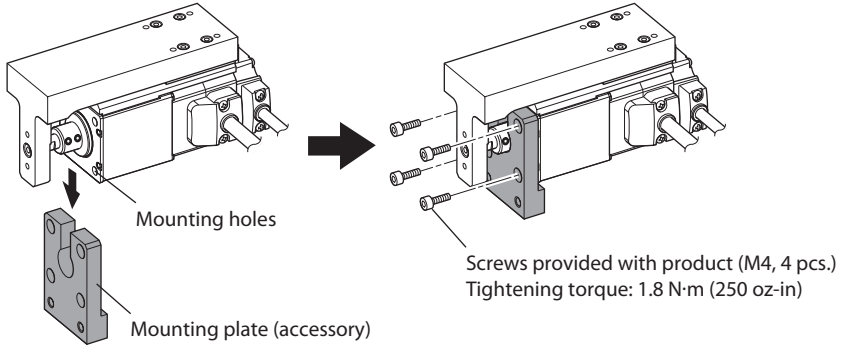

### ■ Mounting methods of the mounting plate (accessory)

There are three methods to secure the mounting plate.

Secure the mounting plate to the base plate using two screws (not supplied).

#### ● Mounting method A

- Screw size: M5
- Effective depth of screw thread: 10 mm
- Tightening torque: 5.0 N·m (710 oz-in)

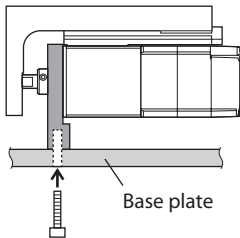

#### ● Mounting method B

- Screw size: M6
- Effective depth of screw thread: 7.5 mm
- Tightening torque: 5.0 N·m (710 oz-in)

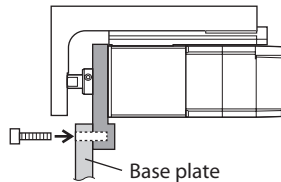

#### ● Mounting method C

- Screw size: M5
- Tightening torque: 5.0 N·m (710 oz-in)

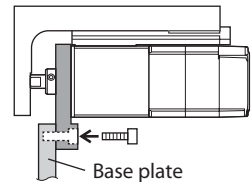

## 5-4 How to install a load

Install a load to the load mounting holes in the joint using screws (not supplied). There are two load mounting surfaces, which are provided on the linear guide side and the ball-screw shaft side.

### ■ When using load mounting holes in the linear guide side of the joint

- Screw size: M4
- Effective depth of screw thread: 5.5 mm (0.22 in.)
- Tightening torque: 1.0 N·m (142 oz·in)

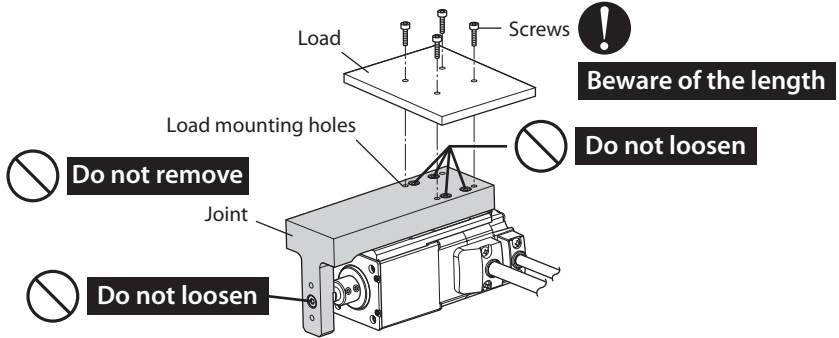

### ⚠ CAUTION

Use the screws which length does not exceed the effective depth of screw threads in the joint when securing a load. Using a too long screw may cause the screw to float, leading to break. This may result in injury or damage to equipment.

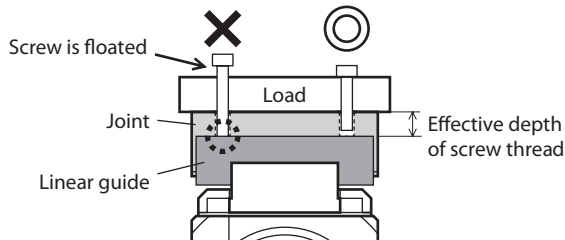

Do not remove the joint from the ball screw shaft. Doing so may deteriorate the installation accuracy of the ball screw shaft, resulting in malfunction. In addition, if the joint is removed, the home position which has been set in the encoder (ABZO sensor) at the time of shipment may deviate. This may cause unexpected movements of the actuator, leading to damage to equipment.

## ■ When using load mounting holes in the ball screw shaft side of the joint

1. Retract the ball screw shaft until it stops at the set collar.
2. Secure the load with screws.
  - Screw size: M4
  - Effective depth of screw thread: 7.5 mm
  - Tightening torque: 1.0 N·m (142 oz-in)

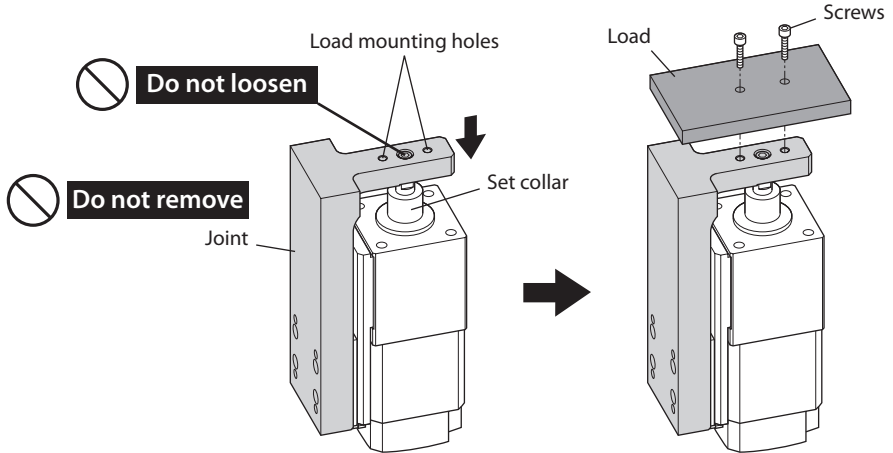

### ⚠ CAUTION



Do not remove the joint from the ball screw shaft. Doing so may deteriorate the installation accuracy of the ball screw shaft, resulting in malfunction. In addition, if the joint is removed, the home position which has been set in the encoder (ABZO sensor) at the time of shipment may deviate. This may cause unexpected movements of the actuator, leading to damage to equipment.

## ■ Notes for when installing a load

- Although the guide type actuator can receive a load moment, use it less than the specifications. Operating the actuator under an excessive load moment may cause malfunction or shorter service life of the actuator. Check on the Oriental Motor Website for the product specifications.
- If you want to move the position of the ball screw shaft when installing a load to an electromagnetic brake type actuator, refer to p.26 to release the electromagnetic brake.

# 6 Installing the non-guide type

---

This section explains the installation location and installation method of the non-guide type actuator.

## 6-1 Installation location

The actuator has been designed and manufactured to be incorporated in general industrial equipment. Install the product in a well-ventilated location that provides easy access for inspection.

- Inside an enclosure that is installed indoors (provide vent holes)
- Operating ambient temperature: 0 to +40 °C [+32 to 104 °F] (non-freezing)
- Operating ambient humidity: 85% or less (non-condensing)
- Area that is free of explosive atmosphere or toxic gas (such as sulfuric gas) or liquid
- Area not exposed to direct sun
- Area free of excessive amount of dust, iron particles or the like
- Area not subject to splashing water (rain, water droplets), oil (oil droplets) or other liquids
- Area free of excessive salt
- Area not subject to continuous vibration or excessive shocks
- Area free of excessive electromagnetic noise (from welders, power machinery, etc.)
- Area free of radioactive materials, magnetic fields or vacuum
- Up to 1000 m (3300 ft.) above sea level

### ■ If a motor is installed in an environment where a magnetic field is generated

A magnetic sensor is built into the encoder (ABZO sensor). If the motor is installed close to equipment which generates a strong magnetic field, the encoder (ABZO sensor) may break or malfunction. Make sure to prevent the magnetic flux density on the surface of the encoder (ABZO sensor) from exceeding 10 mT.



---

Do not install the motor close to equipment which generates a strong magnetic field.

---

## 6-2 Installation overview

The non-guide type actuator cannot be operated without an anti-spin mechanism for the ball screw shaft because the shaft rotates idly. Be sure to provide an anti-spin mechanism such as a guide rail or a movable plate.

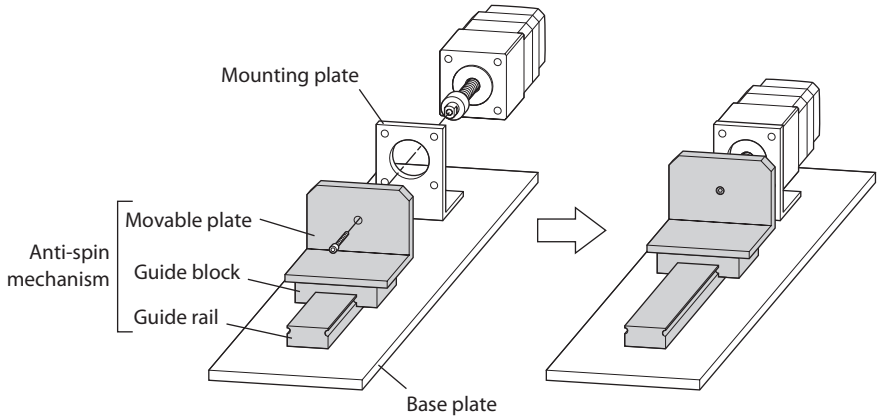

With the non-guide type actuator, the customer is required to perform centering between the actuator and anti-spin mechanism. The installation method varies depending on whether the component parts of anti-spin mechanism have an accuracy that centering can be performed. If the component parts does not have enough accuracy to perform centering, jigs (centering shaft, centering adjustment plate) are needed.

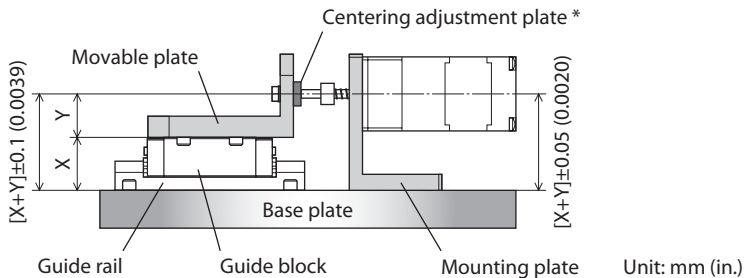

\* It is used when the accuracy of component parts is not enough to perform centering. Also, it is used when the stacking tolerance of parts is adjusted.

### Note

- Be sure to check the installation accuracy using a feeler gauge and others. Low installation accuracy may result in malfunction or shorter service life of the actuator.
- When the electromagnetic brake type actuator is used, refer to p.26 to release the electromagnetic brake before installation. The ball screw shaft cannot be moved unless the electromagnetic brake is released.



## ■ Process of installation

Install the non-guide type actuator according to the following process.

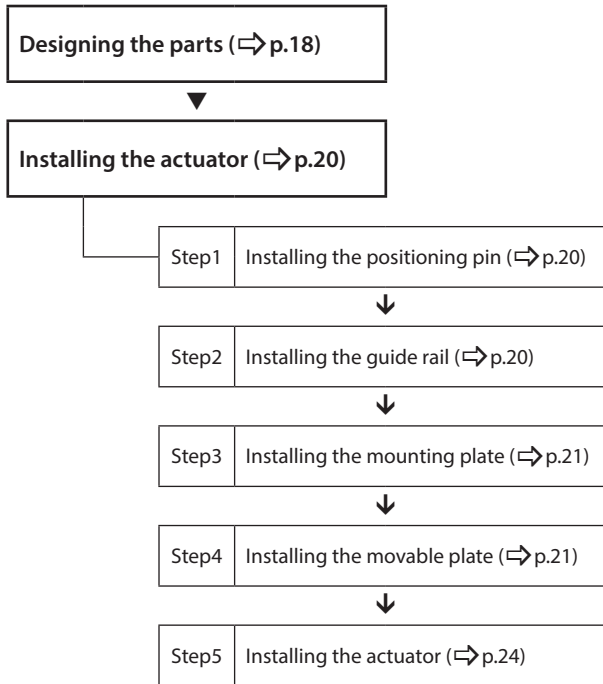

## ■ Details of actuator mounting hole

### ● DRSM42

- Screw size: M4
- Tightening torque: 1.8 N·m (250 oz-in)

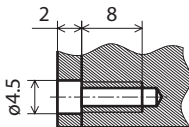

### ● DRSM60

- Screw size: M5
- Tightening torque: 5.0 N·m (710 oz-in)

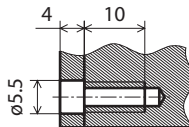

Unit: mm

## 6-3 Installation method

The actuator can be installed in any direction.

Install the actuator onto an appropriate metal flat mounting plate [thickness approximately 5 mm (0.2 in.) or more] having excellent vibration resistance and heat conductivity. If a high accuracy is required, design the thickness of the mounting plate in consideration of installation conditions such as load condition, rigidity, vibration, and others.

A mounting plate is provided as an accessory.

### ■ Component parts design

The following shows the recommended design dimension of component parts and jigs required for when the actuator is installed.

#### ● Movable plate

Design a screw shaft mounting hole ( $\phi C$ ) of the movable plate in consideration of a margin so that the stacking tolerances of parts can be adjusted.

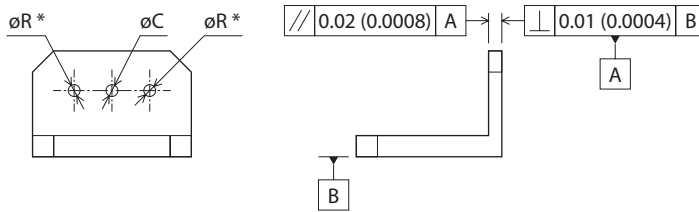

\* They are needed when the accuracy of component parts is not enough to perform centering.

Model	When centering is possible	When centering is difficult	
	$\phi C$	$\phi C$	$\phi R$
<b>DRSM42</b>	4.5 (0.177)	5 (0.20)	4 (0.16)
<b>DRSM60</b>	9 (0.354)	9 (0.35)	6 (0.24)

Unit: mm (in.)

## ● Mounting plate

Perform machining of a flange pilot (counterbore or through hole) on the mounting plate. Design the flange pilot according to the centering shaft (jig) if the accuracy of component parts is not enough to perform centering.

The figure shows an example for a through hole.

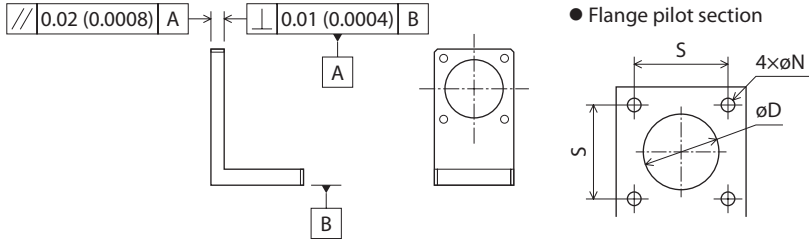

Model	$\phi D$	$\phi N$	S
DRSM42	$25^{+0.021}_0$ [H7] ( $0.98^{+0.0008}_0$ )	4.5 (0.177)	$31 \pm 0.1$ ( $1.22 \pm 0.004$ )
DRSM60	$36^{+0.025}_0$ [H7] ( $1.42^{+0.0010}_0$ )	5.5 (0.22)	$50 \pm 0.1$ ( $1.97 \pm 0.004$ )

Unit: mm (in.)



A mounting plate is provided as an accessory. The accessory mounting plate is a dedicated bracket (steel) to install the actuator onto a base plate. Screws (4 pieces) to secure the actuator to the mounting plate are provided.

## ● Centering shaft and centering adjustment plate

The centering shaft and the centering adjustment plate are jigs used for when the accuracy of component parts is not enough to perform centering. Also, it is used when the stacking tolerance of parts is adjusted.

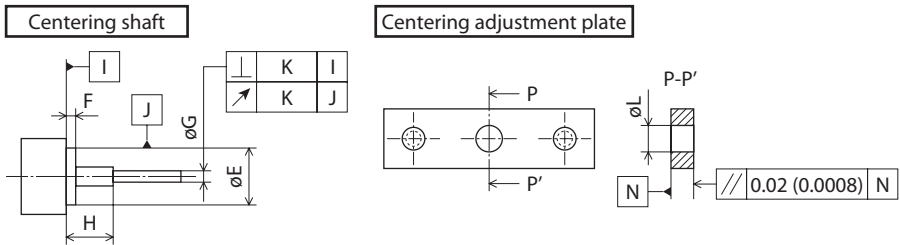

Model	$\phi E$	F	$\phi G$	H	K	$\phi L$
DRSM42	$25^{+0.007}_{-0.020}$ [g6] ( $0.98^{+0.0003}_{-0.0008}$ )	2 (0.079)	$4^{+0.004}_{-0.012}$ ( $0.157^{+0.0002}_{-0.0005}$ )	20 (0.79)	0.02 (0.0008)	$4^{+0.012}_0$ [H7] ( $0.157^{+0.0005}_0$ )
DRSM60	$36^{+0.009}_{-0.025}$ [g6] ( $1.42^{+0.0004}_{-0.0010}$ )	2 (0.079)	$8^{+0.005}_{-0.014}$ ( $0.315^{+0.0002}_{-0.0006}$ )	24.5 (0.96)	0.02 (0.0008)	$8^{+0.015}_0$ (H7) ( $0.315^{+0.0006}_0$ )

Unit: mm (in.)

## ■ Installation procedure

The installation procedure varies based on the accuracy of component parts of equipment.

- If the accuracy of component parts enables centering without adjustment: Centering does not required.
- If the accuracy of component parts is not enough to perform centering: Perform centering using jigs.

### Step1 Installing the positioning pin

Install positioning pins (each 2 pcs.), which are used to set the position of the guide rail and mounting plate, on the base plate.

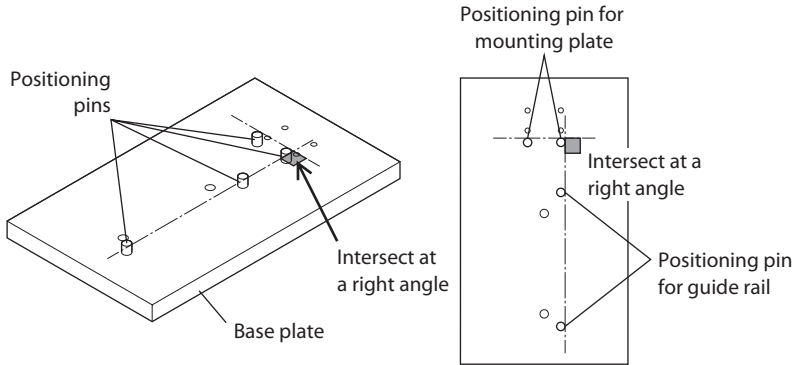

### Step2 Installing the guide rail

Secure a guide rail to the base plate using screws while pressing the reference surface of the guide rail to the positioning pin. Check the manufacturer of a guide rail for the position of the reference surface of the guide rail.

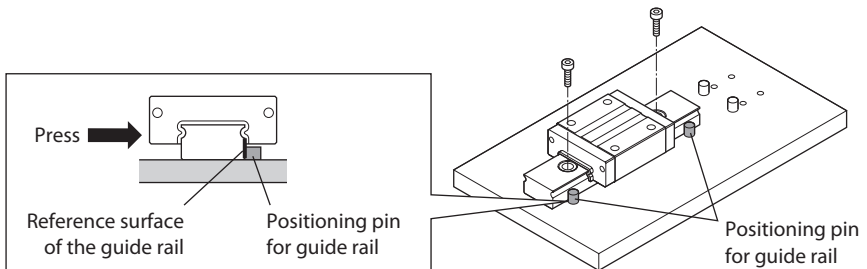

### Step3 Installing the mounting plate

Place the mounting plate on the pins, and secure the mounting plate to the base plate with screws.

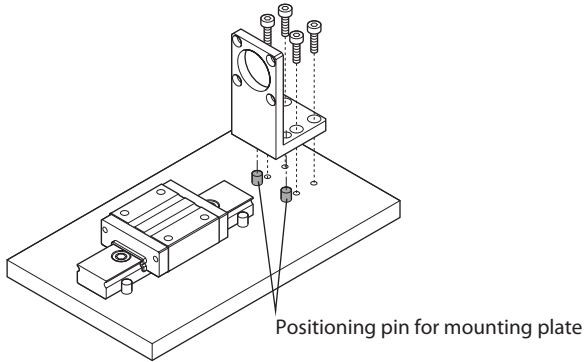

### Step4 Installing the movable plate

Install the movable plate to the guide block. The installation method varies depending on the accuracy of component parts.

#### ● If the accuracy of component parts enables centering without adjustment

1. Install positioning pins on the movable plate.

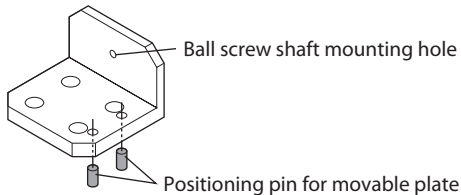

2. Secure the movable plate to the guide block using screws while pressing the positioning pins on the movable plate to the reference surface of the guide block. Check the manufacturer of a guide rail for the position of the reference surface of the guide block.

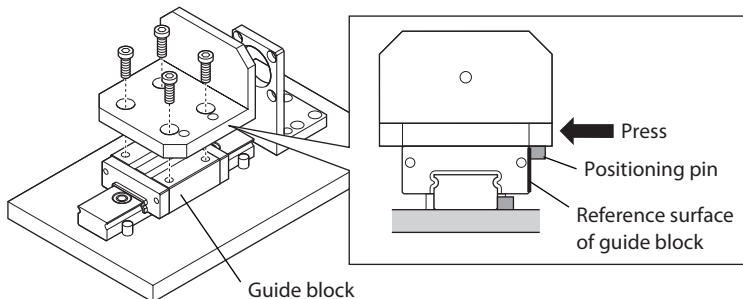

● If the accuracy of component parts is not enough to perform centering

1. Secure the centering adjustment plate to the movable plate using screws.

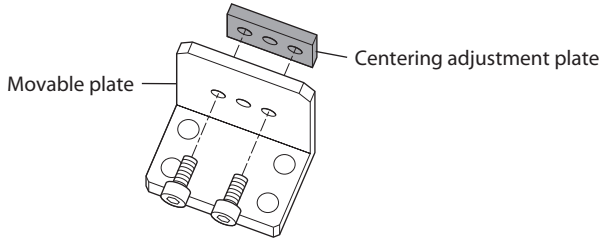

2. Secure the movable plate to the guide block using screws.

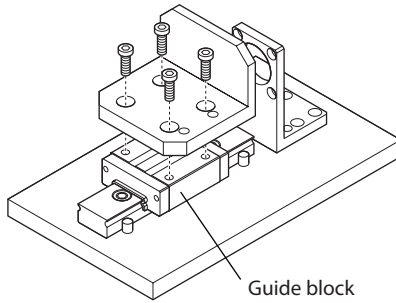

3. Move the movable plate closer to the mounting plate, and check that there is no gap between the plates.

When there is a distance between the movable plate and the mounting plate, put a block gauge, and check that there is no gap between the plates.

If there is a gap, reinstall the movable plate.

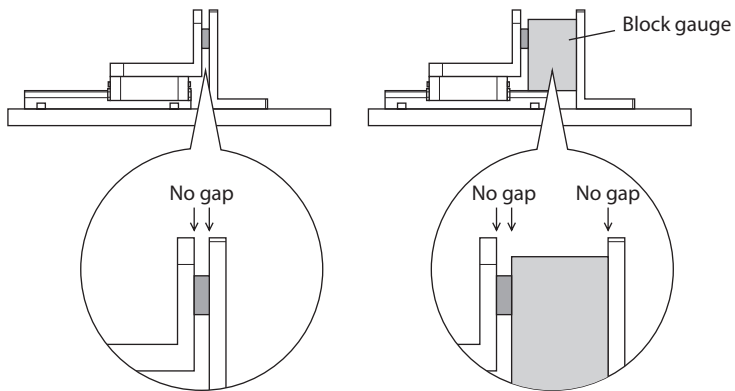

- Using the centering shaft to resemble the actuator, insert the centering shaft to the mounting plate.  
Loosen the screws securing the centering adjustment plate, and temporarily fix the screws so as to move slightly when touching the centering adjustment plate.

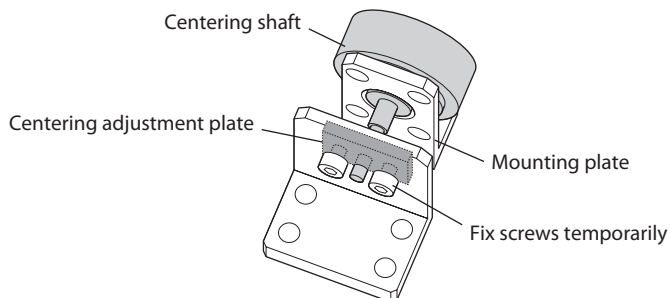

- Slide the movable plate to check that it moves smoothly, and tighten the screws on the centering adjustment plate.  
If the movable plate does not move smoothly, adjust axis misalignment between the centering shaft and the centering adjustment plate while moving the centering adjustment plate from right to left or up and down.

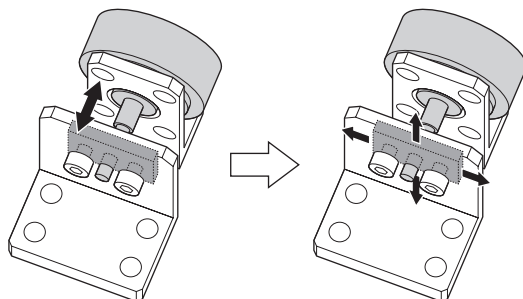

Model	Screw size	Tightening torque *
<b>DRSM42</b>	M3	0.6 N·m (85 oz-in)
<b>DRSM60</b>	M5	3 N·m (420 oz-in)

\* The tightening torques shown in the table are reference values. Tighten the suitable force according to the material and thickness of the centering adjustment plate.

- Remove the centering shaft.

## Step5 Installing the actuator

1. Secure the actuator to the mount plate using screws.  
Secure with the provided screws (4 pieces) when using the accessory mounting plate.

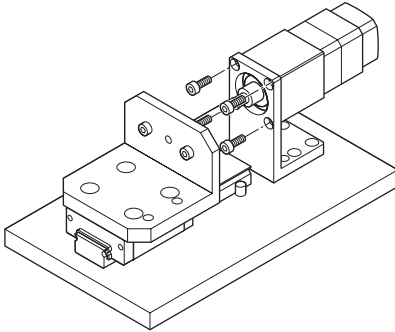

Model	Screw size	Tightening torque
<b>DRSM42</b>	M4	1.8 N·m (256 oz-in)
<b>DRSM60</b>	M5	5 N·m (710 oz-in)

2. Insert the ball screw shaft of the actuator into the ball screw shaft mounting hole of the movable plate, and secure the tip with a screw.

Ball screw shaft mounting hole

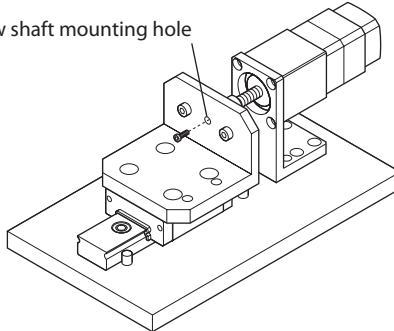

Model	Screw size	Tightening torque	Effective depth of screw threads
<b>DRSM42</b>	M4	1.8 N·m (256 oz-in)	10 mm
<b>DRSM60</b>	M8	5 N·m (710 oz-in)	15 mm

3. Perform test operation to check that no abnormal noise is generated.



# 7 Connection

This chapter explains the grounding method of the actuator as well as the method to release an electromagnetic brake.

## 7-1 Grounding the actuator

Since a grounding wire is included in the "cable for motor," you can ground it only to connect with a driver. However, the grounding resistance value provided in the standards in which the user applies to the equipment may not be satisfied depending on the type or length of the "cable for motor." In this case, also ground the actuator Protective Earth Terminal.

Input voltage	Grounding method	
	Driver	Protective Earth Terminal of actuator
24 VDC	Required	Not required
48 VDC	Required	Ground if the grounding resistance of the standards that applies to the equipment is not satisfied.



When multiple actuators are used in combination, connect each one to the grounding point.

### ■ When connecting to the driver to ground the actuator:

1. Connect the "cable for motor" to the motor connector on the driver.
2. Ground the driver Protective Earth Terminal.

Be sure to ground the Protective Earth Terminal of the driver. Refer to the **AZ Series OPERATING MANUAL** Driver for how to ground the driver.

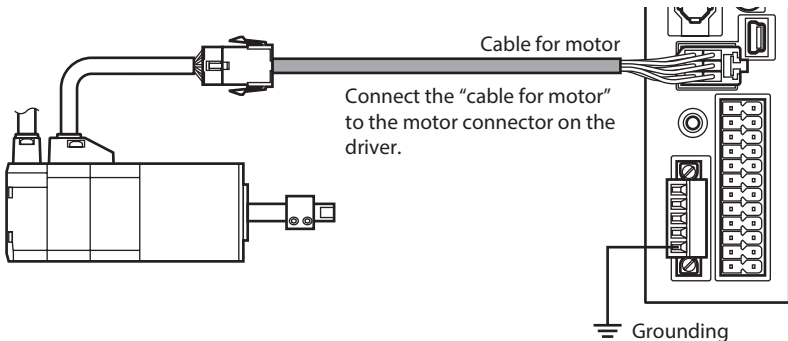

## ■ When grounding the actuator Protective Earth Terminal (48 VDC only):

Be sure to ground the Protective Earth Terminal of the actuator.

- Grounding wire: AWG18 (0.75 mm<sup>2</sup>) or more
- Screw size: M4
- Tightening torque: 1.2 N·m (170 oz-in)

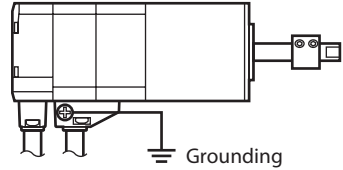

To ground the actuator, use a round terminal, bolt and washer.

Do not share a grounding wire with a welder or any other power equipment.

A grounding wire and crimp terminal are not supplied.

## 7-2 Releasing the electromagnetic brake

Perform according to the following steps to release an electromagnetic brake.

1. Connect the "electromagnetic brake cable" and "cable for electromagnetic brake."

2. Connect the lead wires of the "cable for electromagnetic brake" to the 24 VDC power supply.

Connect the white lead wire to the +24 VDC terminal, and the black lead wire to the GND terminal.

When the power is turned on, the electromagnetic brake is released and the moving part of the actuator can be moved by hand.

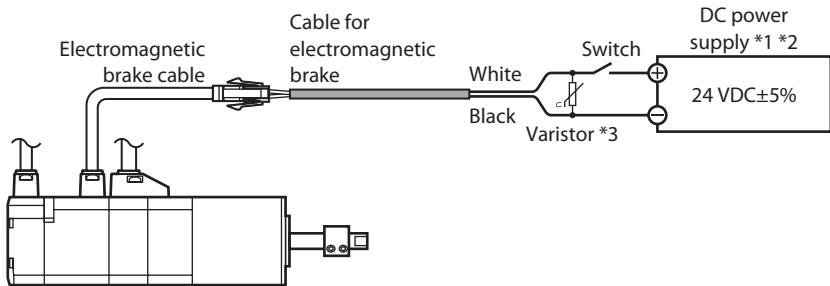

\*1 If the distance between the electromagnetic brake type actuator and the driver is extended to 20 m (65.6 ft.) using an accessory cable, use the power supply of 24 VDC±4%.

\*2 Refer to the following current capacities for the 24 VDC power supply.

**DRSM42:** 0.08 A or more

**DRSM60:** 0.25 A or more

\*3 Connect the varistor to protect the contact of the switch or to prevent electrical noise.  
[Recommended varistor: Z15D121 (SEMITEC Corporation)]



The lead wires of the "cable for electromagnetic brake" have polarities, so connect them in the correct polarities. If the lead wires are connected with their polarities reversed, the electromagnetic brake will not operate properly.

# 8 Maintenance

This chapter explains maintenance items to operate an actuator safely and efficiently. If an abnormal condition is noted, discontinue any use and contact your nearest Oriental Motor sales office.

## 8-1 Inspection item and timing

If the actuator is operated eight hours a day, perform maintenance according to the applicable period specified in the table. Reduce maintenance intervals accordingly if the operating rate is high such as continuous operation for twenty-four hours.

Maintenance timing	External inspection	External cleaning	Internal inspection
When operated for the first time	○	○	—
A week after initial operation	○	○	○
Every a month thereafter	○	○	○

### ■ External inspection

Check the items specified in table.

Item	Description	Remedial action
Actuator	<ul style="list-style-type: none"><li>• Are there any loose screws which have mounted the actuator?</li><li>• Are there any loose screws which have mounted the load?</li></ul>	Tighten the screws securely.
Cable, connector	<ul style="list-style-type: none"><li>• Are there any scratches or areas under stress on the cable?</li><li>• Are there any loose connections on the actuator or driver?</li></ul>	<ul style="list-style-type: none"><li>• Replace the cable.</li><li>• Disconnect and reconnect the connector.</li></ul>
Operation	Is there any abnormal noise or vibration from the bearings, etc.?	Check the installation of the load and operation speed.

### ■ External cleaning

Clean the exterior surface of the actuator whenever necessary.

- Wipe off any dirt and stains using a soft cloth.
- Do not apply compressed air. Dust may enter from a space, resulting in malfunction.
- To remove stubborn stains, wipe the area using a soft cloth moistened with neutral detergent.
- Do not use petroleum solvents, since they will damage the coated surface.

## ■ Internal inspection

Visually check the items specified in table. Even if the grease has turned brown, lubrication condition is deemed appropriate if the running surface still appears glossy. Refer to "8-2 Grease lubrication" for how to apply grease.

Item	Description	Remedial action
Ball screw shaft	Are there any deposits of foreign matter such as dust?	Remove the foreign matter.
	Has the grease lost its gloss or been consumed?	Clean the ball screw shaft with a soft cloth and apply grease to the nut running groove.
Linear guide	Are there any deposits of foreign matter such as dust?	Remove the foreign matter.
	Has the grease lost its gloss or been consumed?	Use a soft cloth to clean the ball rolling grooves on both sides of the linear guide, and add grease from the grease nipple.

## 8-2 Grease lubrication



Wear protective goggles when applying grease. Pay attention to safety and handle the grease carefully by following the instructions provided with that product. If grease gets into the eyes or comes in contact with the skin, immediately flush the area thoroughly with water.

Wipe off the old grease and any dirt completely with a soft cloth, and apply new grease.  
Grease to be used : AFC grease (THK Co., LTD.)

### • Guide type

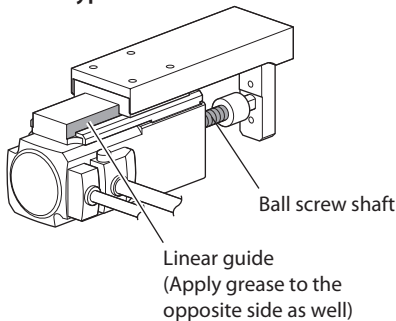

### • Non-guide type

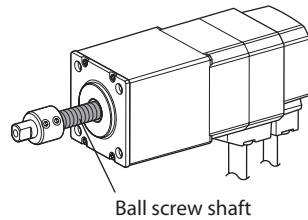

# 9 Standards and general specifications

## 9-1 Standards

### ■ EU Directives

#### ● Installation conditions

Overvoltage category	II
Protection against electric shock	Class I equipment
Pollution degree	3
Noise level	70 dB or less (guide type only)

#### ● EMC Directive

The driver combining with the actuator is affixed the CE Marking under the EMC Directive. For details about applicable standards and others, check with the "OPERATING MANUAL Driver" of the AZ Series.

#### ● Machinery Directive (guide type only)

The actuators and drivers have been designed and manufactured to be incorporated in general industrial equipment, and a Declaration of Incorporation of Partly Completed Machinery is issued with them according to the Machinery Directive.  
Applicable standard: EN ISO 12100

### ■ RoHS Directive

The products do not contain the substances exceeding the restriction values of RoHS Directive (2011/65/EU).

## 9-2 General specifications

	Operating environment	Storage environment	Shipping environment
Degree of protection	–	–	
Ambient temperature	0 to +40 °C [+32 to +104 °F] (non-freezing)	–20 to +60 °C [–4 to +140 °F] (non-freezing)	
Ambient humidity	85% or less (non-condensing)		
Altitude	Up to 1000 m (3300 ft.) above sea level	Up to 3000 m (10,000 ft.) above sea level	

## 9-3 Power supply capacity

Model	Electromagnetic brake	Input power supply voltage	Current capacity
<b>DRSM42</b>	Not equipped	24 VDC±5% * 48 VDC±5%	1.72 A or more
	Equipped		1.80 A or more
<b>DRSM60</b>	Not equipped		2.45 A or more
	Equipped		2.7 A or more

\* If the distance between the electromagnetic brake type actuator and the driver is extended to 20 m (65.6 ft.) using an accessory cable, use the power supply of 24 VDC±4%.

# 10 Troubleshooting and remedial action

During actuator operation, the actuator may fail to function properly due to an improper setting or wiring. When the actuator cannot be operated properly, refer to the contents provided in this section and take an appropriate action. If the problem persists, contact your nearest Oriental Motor sales office.

Phenomenon	Possible cause	Remedial action
While push-motion operation is executed, the ball screw shaft does not move with being jammed in the nut part.	The ball screw shaft was stopped by hitting against a load or others at a speed exceeding the maximum push speed (6 mm/s).	Return the ball screw shaft at the recommended speed shown in the table below, and check if the ball screw shaft and the load are not damaged.
The ball screw shaft does not move with being jammed.	The operation was executed under conditions where the speed or the load was exceeded the specification value.	Return the ball screw shaft at the recommended speed shown in the table below. After that, check the following items. <ul style="list-style-type: none"> <li>• Are the ball screw shaft and the load damaged?</li> <li>• Are the positions of the set collar and the home position displaced?</li> </ul>
The ball screw shaft does not operate at the command speed.	The torque of the actuator is not enough against a load.	Review the load.
The ball screw shaft rotates idly. (for non-guide type actuator)	An anti-spin mechanism is not provided.	Be sure to provide an anti-spin mechanism for the non-guide type actuator.
Malfunction of actuator	<ul style="list-style-type: none"> <li>• The installation accuracy is low.</li> <li>• A load moment exceeding the specification value is applied.</li> </ul>	<ul style="list-style-type: none"> <li>• Check the installation accuracy.</li> <li>• Use the actuator with a load moment of the specification value or smaller.</li> </ul>
The thrust force of the actuator has lowered.	<ul style="list-style-type: none"> <li>• The wiring distance is exceeded the specification value.</li> <li>• The viscosity of the grease was changed.</li> </ul>	<ul style="list-style-type: none"> <li>• Keep 20 m (65.6 ft.) or less for the wiring length between the actuator and driver.</li> <li>• Refer to p.29, and check the operating ambient temperature.</li> </ul>

## Recommended starting speed

Model	Lead	Recommended starting speed
<b>DRSM42</b>	2 mm	0.4 mm/s
	8 mm	1.6 mm/s
<b>DRSM60</b>	4 mm	0.8 mm/s

- Unauthorized reproduction or copying of all or part of this Operating Manual is prohibited. If a new copy is required to replace an original manual that has been damaged or lost, please contact your nearest Oriental Motor branch or sales office.
- Oriental Motor shall not be liable whatsoever for any problems relating to industrial property rights arising from use of any information, circuit, equipment or device provided or referenced in this manual.
- Characteristics, specifications and dimensions are subject to change without notice.
- While we make every effort to offer accurate information in the manual, we welcome your input. Should you find unclear descriptions, errors or omissions, please contact the nearest office.
- **Orientalmotor** and ABZO sensor are registered trademarks or trademarks of Oriental Motor Co., Ltd., in Japan and other countries.  
Other product names and company names mentioned in this manual may be registered trademarks or trademarks of their respective companies and are hereby acknowledged. The third-party products mentioned in this manual are recommended products, and references to their names shall not be construed as any form of performance guarantee. Oriental Motor is not liable whatsoever for the performance of these third-party products.

© Copyright ORIENTAL MOTOR CO., LTD. 2015

Published in June 2018

• Please contact your nearest Oriental Motor office for further information.

ORIENTAL MOTOR U.S.A. CORP  
Technical Support Tel:(800)468-3982  
8:30 A.M. to 5:00 P.M., P.S.T. (M-F)  
7:30 A.M. to 5:00 P.M., C.S.T. (M-F)  
www.orientalmotor.com

ORIENTAL MOTOR DO BRASIL LTDA.  
Tel:+55-11-3266-6018  
www.orientalmotor.com.br

ORIENTAL MOTOR (EUROPA) GmbH  
Schiessstraße 44, 40549 Düsseldorf, Germany  
Technical Support Tel:00 800/22 55 66 22  
www.orientalmotor.de

ORIENTAL MOTOR (UK) LTD.  
Tel:01256-347090  
www.oriental-motor.co.uk

ORIENTAL MOTOR (FRANCE) SARL  
Tel:01 47 86 97 50  
www.orientalmotor.fr

ORIENTAL MOTOR ITALIA s.r.l.  
Tel:02-93906346  
www.orientalmotor.it

ORIENTAL MOTOR ASIA PACIFIC PTE. LTD.  
Singapore  
Tel:1800-8420280  
www.orientalmotor.com.sg

ORIENTAL MOTOR (MALAYSIA) SDN. BHD.  
Tel:1800-806161  
www.orientalmotor.com.my

ORIENTAL MOTOR (THAILAND) CO., LTD.  
Tel:1800-888-881  
www.orientalmotor.co.th

ORIENTAL MOTOR (INDIA) PVT. LTD.  
Tel:+91-80-41125586  
www.orientalmotor.co.in

TAIWAN ORIENTAL MOTOR CO., LTD.  
Tel:0800-060708  
www.orientalmotor.com.tw

SHANGHAI ORIENTAL MOTOR CO., LTD.  
Tel:400-820-6516  
www.orientalmotor.com.cn

INA ORIENTAL MOTOR CO., LTD.  
Korea  
Tel:080-777-2042  
www.inaom.co.kr

ORIENTAL MOTOR CO., LTD.  
Hong Kong Branch  
Tel:+852-2427-9800

ORIENTAL MOTOR CO., LTD.  
4-8-1 Higashiueno, Taito-ku, Tokyo  
110-8536 Japan  
Tel:03-6744-0361  
www.orientalmotor.co.jp