

Motorized Linear Slides
EZ limo
EZS II Series





Advancing Positioning Applications

Oriental Motor's Motorized Linear Slides EZ limo

The **EZSII** Series motorized linear slide is designed to achieve greater convenience and performance in positioning applications. The drive motor adopts the closed-loop ***αSTEP*** stepping motor that eliminates misstep and hunting. **EZSII** Series is combined with a user-friendly controller that can set all functions needed to operate a motorized linear slide. The teaching pendant, editing software, cables and other optional parts can be available.

Introducing **NEW** **EZ limo**

EZS II Series

The high-precision, compact body was made possible by adopting a rolled ball screw and guide frame structure. The compact design facilitates installation and wiring to your system for added convenience.

EZS3 Linear Slide Width 54 mm×Height 50 mm

EZS4 Linear Slide Width 74 mm×Height 50 mm

EZS6 Linear Slide Width 74 mm×Height 66.5 mm

Space-Saving Design
Easy Wiring, Easy Assembly

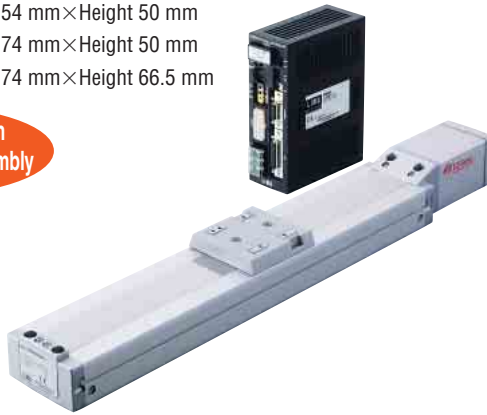

Drive Method: Rolled ball screw

Maximum Stroke **850** mm

Maximum Speed **800** mm/s

Maximum Transportable Mass Horizontal **60** kg / Vertical **30** kg

Repetitive Positioning Accuracy ± 0.02 mm

Power Supply Voltage **24 VDC,**
Single-Phase 200-230 VAC

The above figures are representative values. For details, see the product information page.

Accessories

A teaching pendant and data editing software etc.



Combining All Functions Needed to Operate a Motorized Linear Slide in Positioning Operations

This controller lets you operate all the functions required of a motorized linear slide, in easy steps.



Positioning data of up to 63 points can be set with ease (when the controller is used in the controller mode).

Position data can be set in one of three methods, as specified below.

1. Enter the desired travel (mm) directly.



2. Direct Teaching

Move the table to the target position by manual, and store the achieved position as positioning data.

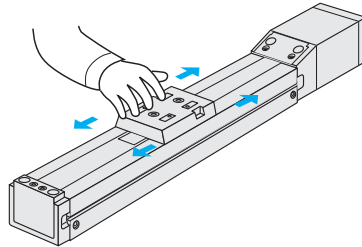

3. Remote Teaching

Move the table to the target position using a teaching pendant or data editing software, and store the achieved position as positioning data.

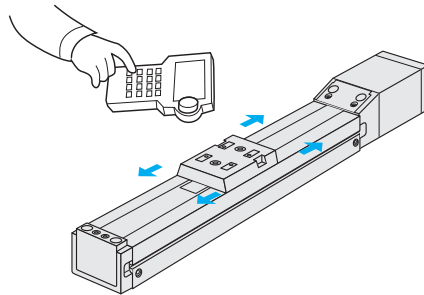

Two Positioning Data Settings: Absolute and Incremental Modes

You can set positioning data in the absolute mode or incremental mode, depending on your preferred movement of the equipment.

● Absolute Mode:

Each position is set as the absolute position with respect to the reference point. This is suitable when you want to move the work directly from an arbitrary position to the specified position.

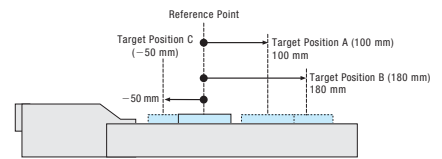

● Incremental Mode:

Each position is relative, being set as an amount of travel from the current position or another target position for the work. This is done in a regular feed or other operation where the same pattern is used repeatedly.

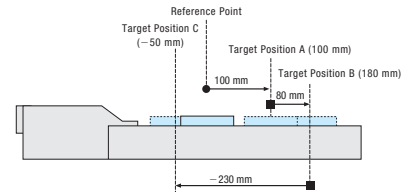

Two Data Execution Modes: Selective Positioning and Sequential Positioning

● Selective positioning mode:

The set data can be selected at random.

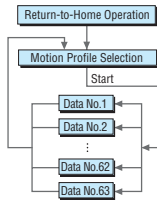

● Sequential positioning mode:

Positioning operation is performed sequentially from the desired data.

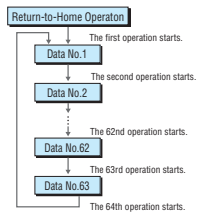

Area Output Function

A signal is output when the linear slide table enters a set area arbitrarily set along the stroke. One set area can be set.

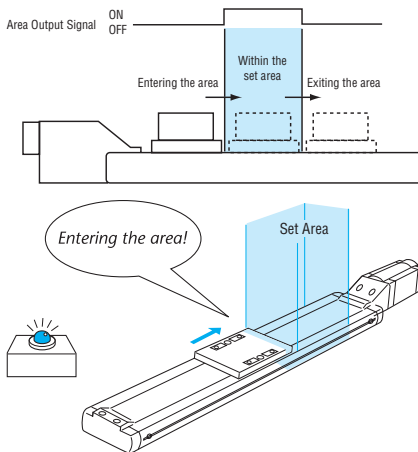

Linked Operation

Up to 4 operation data can be linked, thereby allowing the motor to change speeds without stopping.

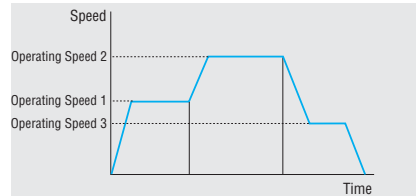

Note:

- Data with the same operation direction can be linked.

Separate Acceleration and Deceleration Settings

Acceleration and deceleration can be set separately for each positioning data.

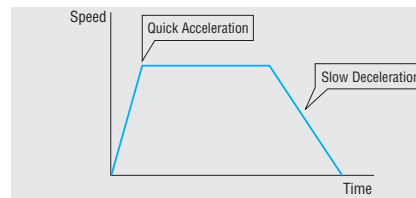

Choice of Two Return-to-Home Methods

● Sensorless Return-to-Home

Return-to-home is performed without the use of external sensors. The home position can be adjusted. For the linear slides, the direction of return-to-home can also be changed.

● Return-to-Home Using Sensors

Return-to-home is performed using home sensors. The sensors are available as options (sold separately)*.

(*See page 44 for the sensor set.)

Operation Using External Pulse Input

The EZ limo can be combined with your existing controller to serve as a driver controlling the linear slide by pulse input.

	Controller Mode	Driver Mode*
Teaching Function	●	×
Monitoring Function	●	×
Pause Function	●	×
Area Output Function	●	×
Absolute Type	●	●
Sensorless Return-to-Home	●	●
Return-to-Home using Sensor	●	●*

*Data must be set from the teaching pendant or data setting software.

● Normal System Configuration (Controller Mode)

The linear slide is controlled by selecting positioning data preset in the controller.

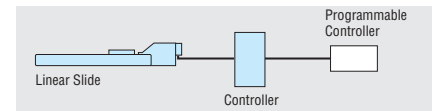

● When Combined with the Customer's Controller [Driver Mode]

The linear slide is controlled by inputting pulse signals.

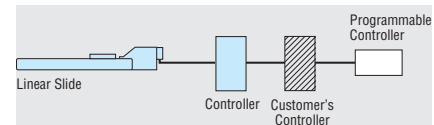

Output of Current Position and Error Code

The current position, error code and certain other data can be output to an external device.

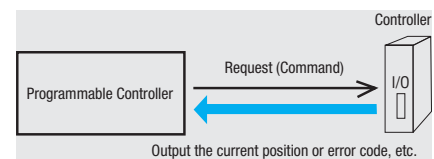

Easy Editing of Positioning Data

The teaching pendant and data editing software are available. Choose an appropriate accessory based on the required functions.



Functions of Teaching Pendant (EZT1) and Data Editing Software (EZED2)

The table below summarizes the functions available with the teaching pendant (EZT1) and data editing software (EZED2).

Choose an appropriate tool based on the required functions.

Function	Item	
	Teaching Pendant (Model: EZT1)	Data Editing Software (Model: EZED2)
Cable Length	5m	5m*1
Display	LCD 17 characters×4 lines	PC screen
Emergency Stop Switch	○	×
Operation Data Setting	○	○
Parameter Setting	○	○
Teaching Function (Direct/Remote)	○	○
Operation Data Monitoring	○	○
I/O & Alarm History Monitoring	○	○
Waveform Monitoring	×	○
Test Operation	○	○
Data Copy	×	○
Printing Function	×	○*2

*1 PC interface cable (supplied) is used.

*2 The printing function is not available on computers running Windows® 98/Me.

Teaching Pendant (sold separately) Model: EZT1



- All functions required for operation and adjustment, including setting of positioning data, test operation, and I/O monitoring, are provided.
- The dialogue-type user interface ensures easy operation. All you need is to enter values in the necessary fields.
- No dedicated power supply is necessary. Simply connect the cable to the controller.

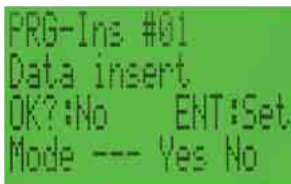

Data Editing Software (sold separately) Model: EZED2



- All functions required for operation and adjustment, including setting of positioning data, test operation, and I/O monitoring, are provided.
- Running on any Windows computer, the software is a graphic navigation tool that guides you through various operations in easy steps. This user-friendly feature makes this ideal accessory for editing large volumes of data.
- You can also access waveform monitoring, data copy and other features not available on the teaching pendant.

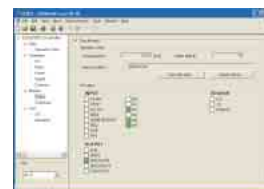
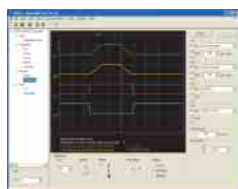

Selection of Motorized Linear Slides EZS II Series

Linear Slide Size		EZS3				EZS4				EZS6					
Linear Slide Width × Height		54 mm × 50 mm				74 mm × 50 mm				54 mm × 66.5 mm					
Screw Type		Rolled Ball Screw													
Power Supply Voltage		24 VDC		Single-Phase 200-230 VAC		24 VDC		Single-Phase 200-230 VAC		24 VDC		Single-Phase 200-230 VAC			
Lead	[mm]	12	6	12	6	12	6	12	6	12	6	12	6		
Maximum Load Moment [N·m]	M _P	4.2				8				45.7					
	M _V	4				8				12.5					
	M _R	10.5				27.8				55.6					
Maximum Transportable Mass in Horizontal Direction [kg]	60														
	10	7.5	15	7.5	15	15	30	15	30	30	30	60	30	60	
Maximum Transportable Mass in Vertical Direction [kg]	30														
	5	3.5	7	3.5	7	7	14	7	14	15	15	30	15	30	
Maximum Speed [mm/s]	800														
	100	600	300	800	400	600	300	800	400	600	300	800	400	400	
Repetitive Positioning Accuracy [mm]		±0.02													
Stroke [mm]	800														
	50	50	50	50	50	50	50	50	50	50	50	50	50	50	
50-mm increments	700	700	700	700	700	700	700	700	700	700	700	850	850	850	850
Electromagnetic Brake		With electromagnetic brake and without electromagnetic brake are available													

Model Selection Method

Select a linear slide of the size that satisfies your desired condition.
 Select an appropriate model by following the steps below.

1. Select a Linear Slide Satisfying the Transportable Mass

By referring to "■ Specifications of Linear Slide," select a linear slide satisfying the transportable mass.

Condition: Drive a 15-kg work over a horizontal distance of 400 mm within 1.5 seconds.

EZS4: Specifications of Linear Slide [74 mm (W) × 50 mm (H), 24 VDC]

■ Specifications of Linear Slide (RoHS) CE																			
Drive Method		Rolled Ball Screw		Repetitive Positioning Accuracy [mm]		±0.02		Resolution [mm]		0.01		Traveling Parallelism [mm]		0.03*		Maximum Load Moment [N·m]		Mr:8 Mv:8 Ma:27.8	
Model	Lead [mm]	Transportable Mass [kg]		Maximum Speed (Stroke) [mm/s]				Thrust Force [N]	Electromagnetic Brake Holding Force [N]										
		Horizontal	Vertical	50~550 mm	560~600 mm	610~650 mm	660~700 mm												
EZS4D □-K	12	~15	—	600	550	460	400	~70	—										
EZS4D □M-K			~7						70										
EZS4E □-K	6	~30	—	300	270	220	200	~140	—										
EZS4E □M-K			~14						140										

● The box (□) in the model name represents the code for stroke length.
 *This applies when the linear slide is installed from the base surface.

Based on the "Condition" and "Specifications of Linear Slide," you select **EZS4D040-K**.

2. Check the Positioning Time

From the graph below "■ Positioning Distance – Positioning Time," check if the selected linear slide satisfies the desired positioning time. As a rough guideline, the positioning time required by the selected linear slide corresponds to the positioning time identified from the graph, multiplied by the "positioning time coefficient" applicable to the linear slide.

From the graph, find the required positioning time for the "positioning distance of 400 mm." You obtain the "positioning time of 1.2 s." Since the stroke is below 550 mm, multiply "1.2 s" by the "positioning time coefficient of 1.0" to obtain an approximate positioning time.

Note:

- The calculated positioning time does not include the settling time.
- Use a settling time of 0.15 s as a reference.

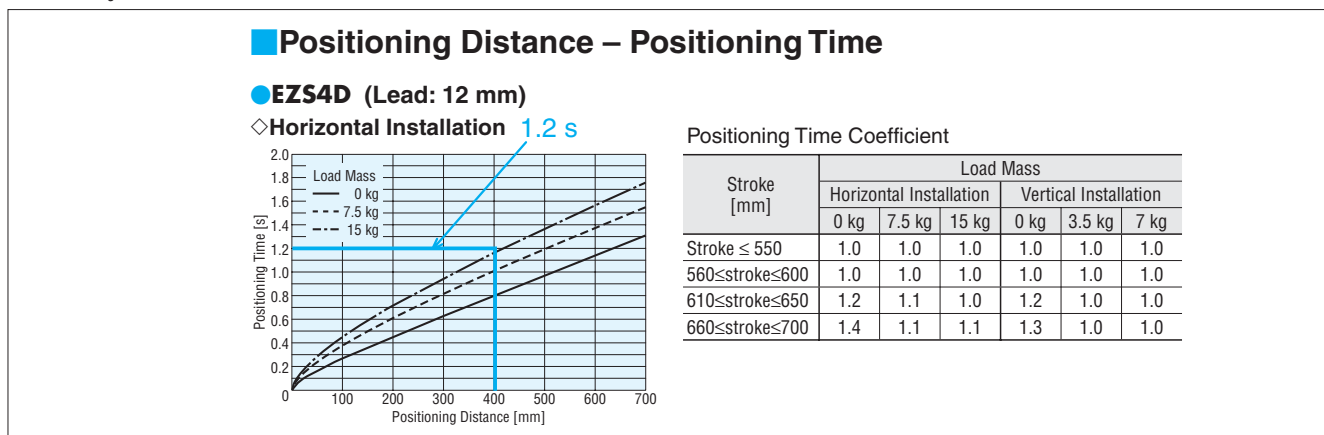

3. Check the Operating Speed and Acceleration of the Linear Slide

The time calculated from "■ Positioning Distance – Positioning Time" assumes the operating speed and acceleration that achieve the shortest positioning time. Check the specific operating speed and acceleration at which to drive the linear slide based on the time calculated in Step 2.

● Operating Speed and Acceleration of the Linear Slide

Check the operating speed and acceleration by referring to "■ Positioning Distance – Operating Speed" and "■ Positioning Distance – Acceleration." If the identified speed exceeds the "maximum speed specified in ■ Specifications of Linear Slide," use the "maximum speed specified in ■ Specifications of Linear Slide" as the operating speed of the linear slide.

Example) From the graphs, the operating speed and acceleration at the positioning distance of 400 mm are 480 mm/s and 1.5 m/s², respectively.

EZS4D040-K "■ Positioning Distance – Operating Speed"

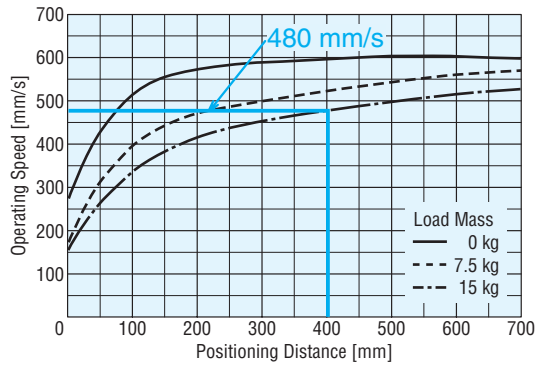

EZS4D040-K "■ Positioning Distance – Acceleration"

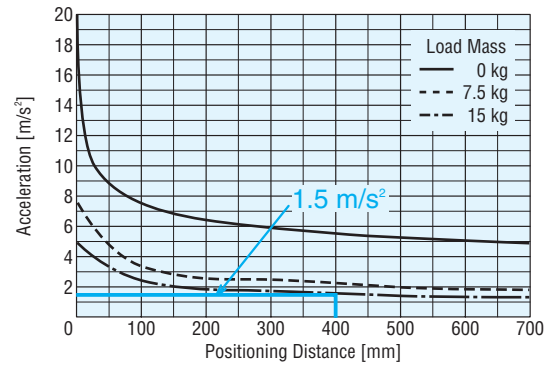

4. Check the Load Moment

Calculate the load moment that will generate under the applicable condition, and confirm that the calculated result is smaller than the "maximum load moment specified in ■ Specifications of Linear Slide." If the maximum load moment is exceeded, select another model. The maximum load moment has been calculated by considering the estimated traveling life of each model. If a given model is operated at load moments exceeding the designed limit, the service life of the linear slide will decrease. The service life is also affected by the use environment and operating conditions.

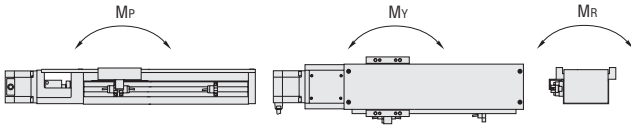

Note:

● As a rule, the operating duty, which represents the relationship of operating time and stationary time, should be kept to 50% or below (rough guideline).

$$\text{Operation Duty [\%]} = \text{Operating Time [s]} \times 100 / (\text{Operating Time [s]} + \text{Stopping Time [s]})$$

EZS II Series: Positioning Distance – Operating Speed, Positioning Distance – Acceleration

EZS3D-K (Lead: 12 mm, 24 VDC)

Horizontal Installation

Positioning Distance – Operating Speed

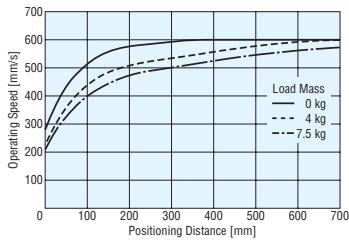

Positioning Distance – Acceleration

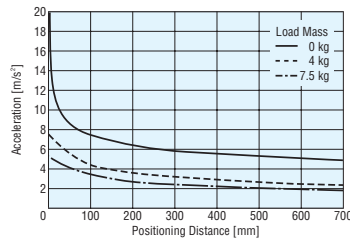

Vertical Installation

Positioning Distance – Operating Speed

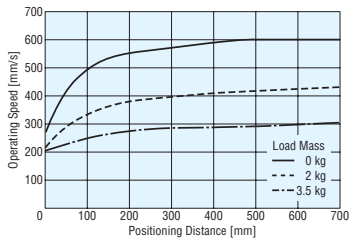

Positioning Distance – Acceleration

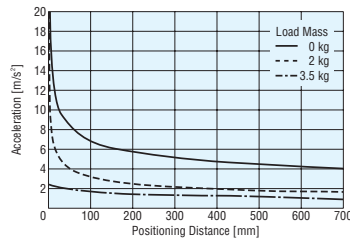

EZS3E-K (Lead: 6 mm, 24 VDC)

Horizontal Installation

Positioning Distance – Operating Speed

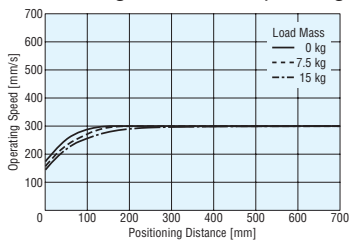

Positioning Distance – Acceleration

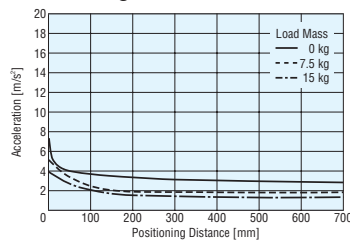

Vertical Installation

Positioning Distance – Operating Speed

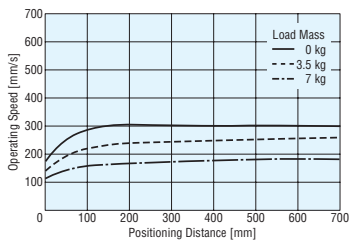

Positioning Distance – Acceleration

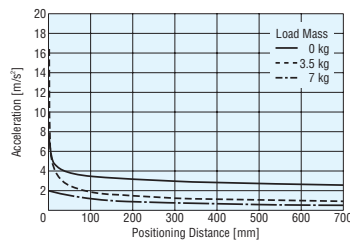

EZS3D-C (Lead: 12 mm, Single-phase 200-230 VAC)

Horizontal Installation

Positioning Distance – Operating Speed

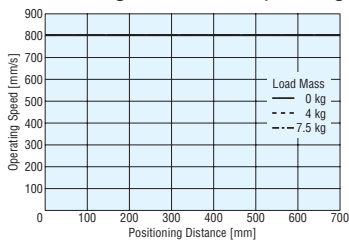

Positioning Distance – Acceleration

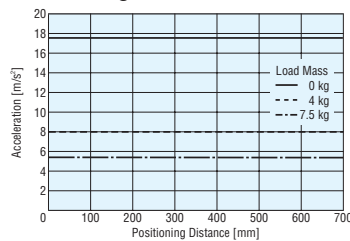

Vertical Installation

Positioning Distance – Operating Speed

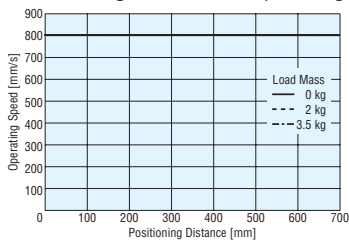

Positioning Distance – Acceleration

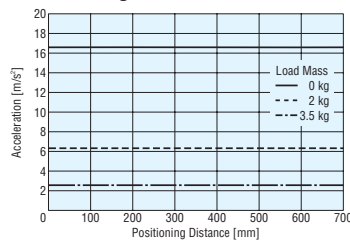

●EVS3E□-C (Lead: 6 mm, Single-phase 200-230 VAC)

◇Horizontal Installation

• Positioning Distance – Operating Speed

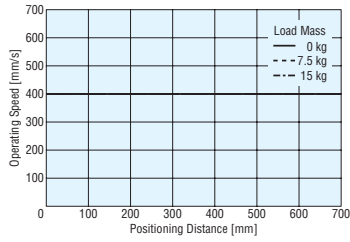

• Positioning Distance – Acceleration

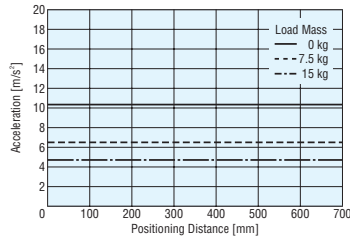

◇Vertical Installation

• Positioning Distance – Operating Speed

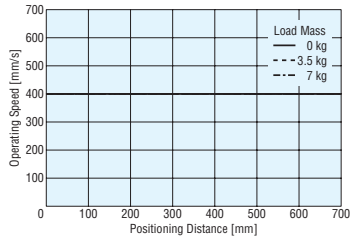

• Positioning Distance – Acceleration

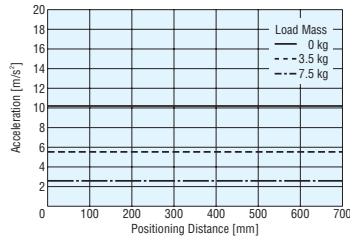

●EVS4D□-K (Lead: 12 mm, 24 VDC)

◇Horizontal Installation

• Positioning Distance – Operating Speed

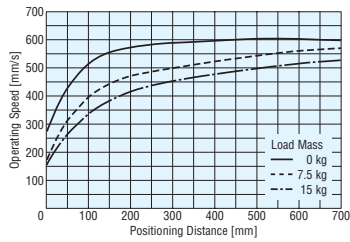

• Positioning Distance – Acceleration

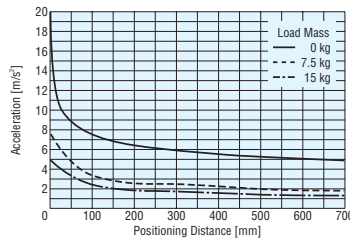

◇Vertical Installation

• Positioning Distance – Operating Speed

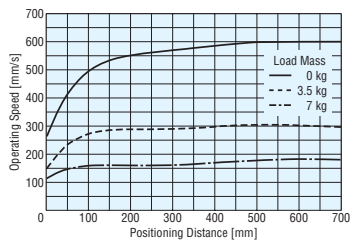

• Positioning Distance – Acceleration

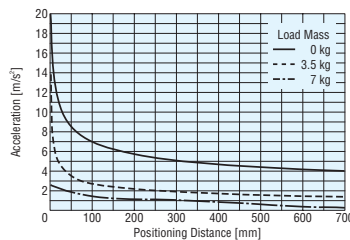

●EVS4E□-K (Lead: 6 mm, 24 VDC)

◇Horizontal Installation

• Positioning Distance – Operating Speed

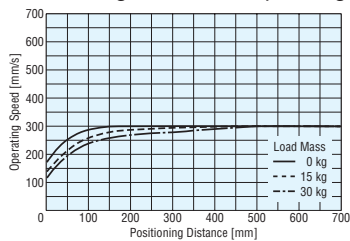

• Positioning Distance – Acceleration

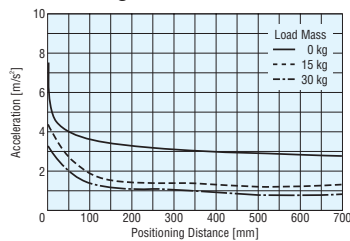

◇Vertical Installation

• Positioning Distance – Operating Speed

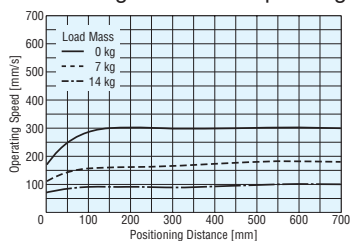

• Positioning Distance – Acceleration

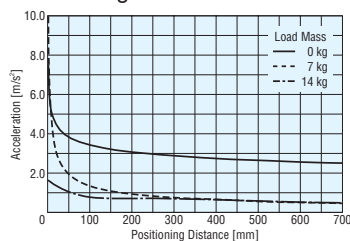

EZS4D-C (Lead: 12 mm, Single-phase 200-230 VAC)

◇ Horizontal Installation

• Positioning Distance – Operating Speed

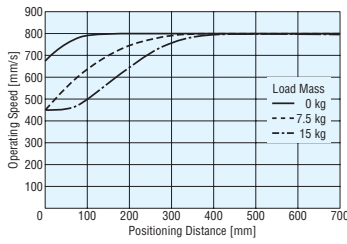

• Positioning Distance – Acceleration

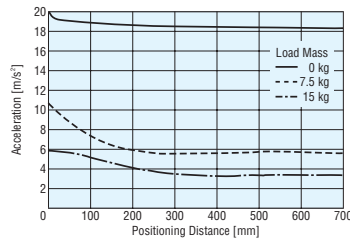

◇ Vertical Installation

• Positioning Distance – Operating Speed

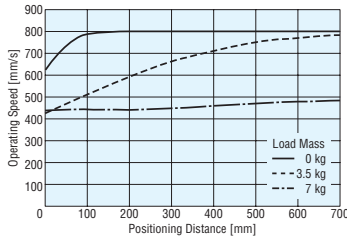

• Positioning Distance – Acceleration

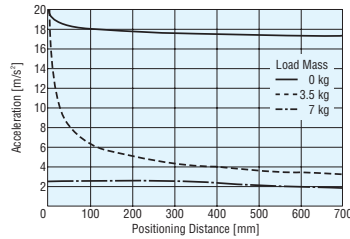

EZS4E-C (Lead: 6 mm, Single-phase 200-230 VAC)

◇ Horizontal Installation

• Positioning Distance – Operating Speed

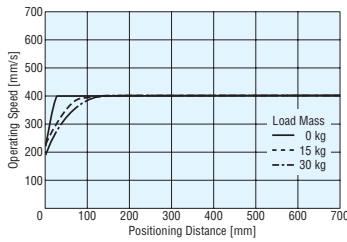

• Positioning Distance – Acceleration

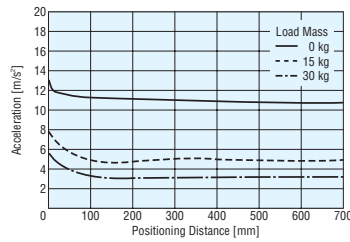

◇ Vertical Installation

• Positioning Distance – Operating Speed

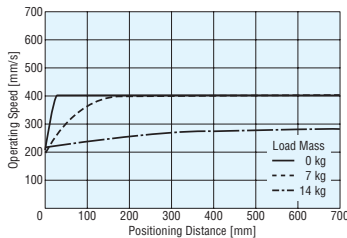

• Positioning Distance – Acceleration

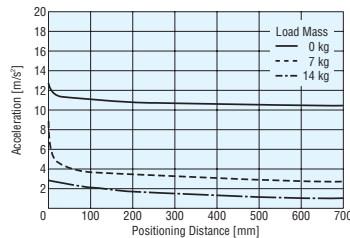

EZS6D-K (Lead: 12 mm, 24 VDC)

◇ Horizontal Installation

• Positioning Distance – Operating Speed

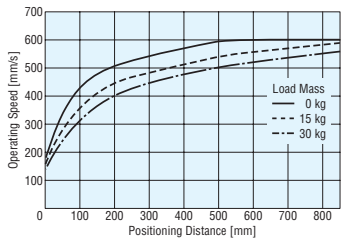

• Positioning Distance – Acceleration

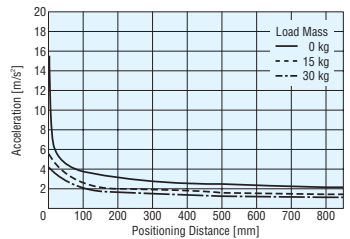

◇ Vertical Installation

• Positioning Distance – Operating Speed

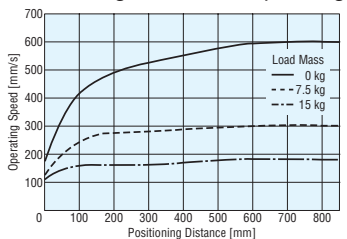

• Positioning Distance – Acceleration

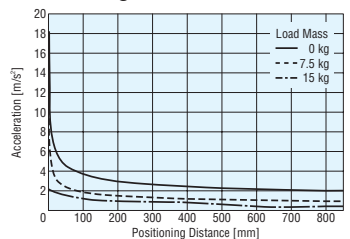

● **EZS6E□-K (Lead: 6 mm, 24 VDC)**

◇ **Horizontal Installation**

• Positioning Distance – Operating Speed

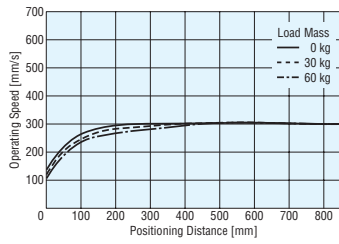

• Positioning Distance – Acceleration

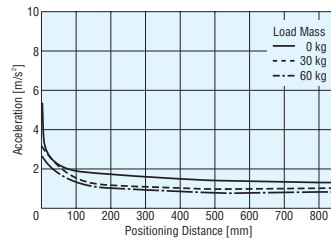

◇ **Vertical Installation**

• Positioning Distance – Operating Speed

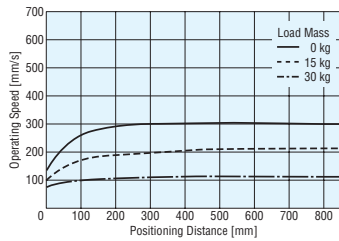

• Positioning Distance – Acceleration

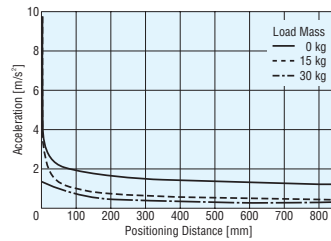

● **EZS6D□-C (Lead: 12 mm, Single-phase 200-230 VAC)**

◇ **Horizontal Installation**

• Positioning Distance – Operating Speed

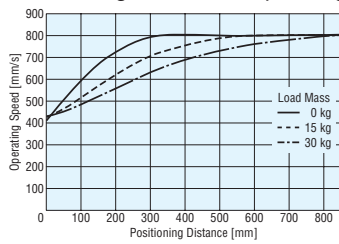

• Positioning Distance – Acceleration

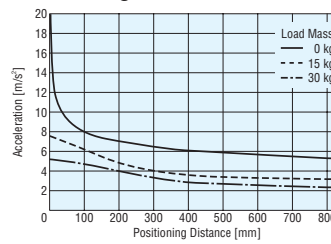

◇ **Vertical Installation**

• Positioning Distance – Operating Speed

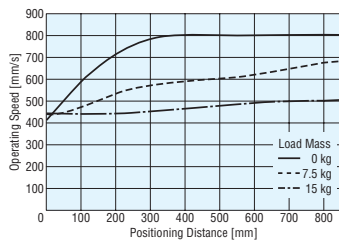

• Positioning Distance – Acceleration

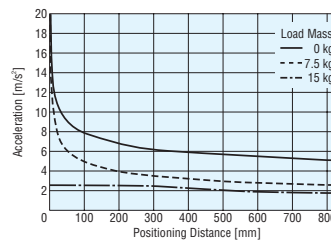

● **EZS6E□-C (Lead: 6 mm, Single-phase 200-230 VAC)**

◇ **Horizontal Installation**

• Positioning Distance – Operating Speed

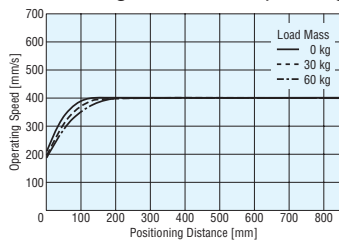

• Positioning Distance – Acceleration

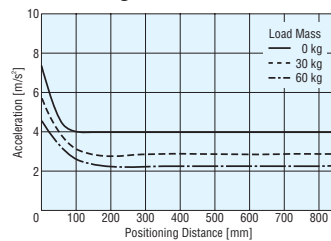

◇ **Vertical Installation**

• Positioning Distance – Operating Speed

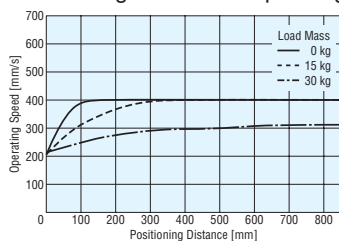

• Positioning Distance – Acceleration

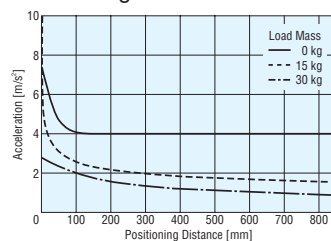

Motorized Linear Slides

EZ limo EZSII Series

The structure of this motorized linear slide has been optimized to achieve greater convenience and performance in positioning applications. The compact design facilitates installation and wiring to your system.

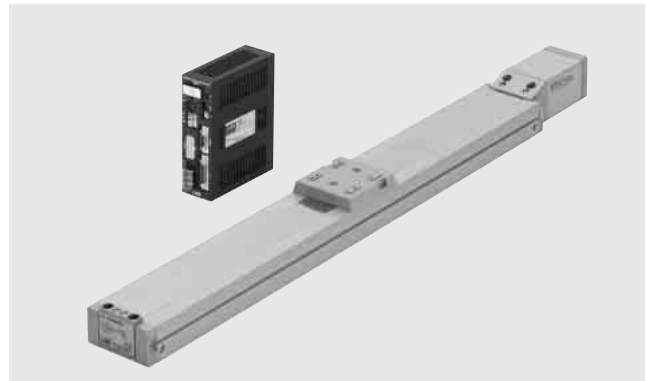

■ Features

- Adopting a closed-loop α STEP stepping motor, this linear slide eliminates misstep and hunting, while attaining high-speed and high-response operation.

The linear slide has no hunting problem upon stopping and the vibration level is incredibly low. The controller employs advanced technology that produces smoothness comparable to a microstepping driver.

- High-speed positioning carrying a heavy load

EZS6 (lead: 6 mm): Maximum transportable mass **60** kg

EZS3/4/6 (lead: 12 mm): Maximum speed **800** mm/s
(Single-phase 200-230 VAC Input)

- Driving the space-saving design of your system

The total length of linear slide is shorter for every stroke or model.

EZS3, EZS4: Total length of linear slide = Stroke + 209.5 mm
Since the space outside the linear slide's operating range is minimized, the overall system size can be reduced.

- Easy wiring between the linear slide and controller
The linear slide and controller are connected via a single cable, and the wiring distance can be extended to a maximum of 20 m*.

*Maximum of 10 m for 24 VDC products.

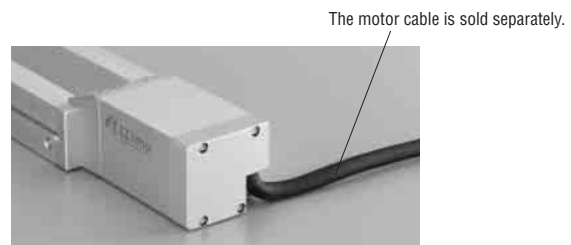

The connector is attached at the end of the cable for easy connection.

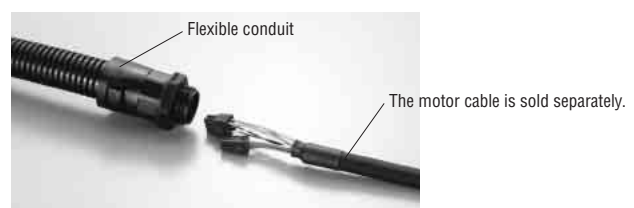

The cable can be placed in a flexible conduit or cable gland with an inner diameter of $\phi 16.5$ mm.

General Specifications of Motor

(General Specifications of Controller →Page 33)

This is the value after rated operation at normal temperature and normal humidity.

24 VDC

Item	Specification
Insulation Resistance	100 MΩ minimum when measured by a 500 VDC megger between the following places. • Motor case–Motor/Sensor windings • Motor case–Windings of electromagnetic brake (Only for electromagnetic brake equipped model)
Dielectric Strength	Sufficient to withstand the following for one minute. • Motor case–Motor/Sensor windings 0.5 kVAC 50 Hz • Motor case–Windings of electromagnetic brake (Only for electromagnetic brake equipped model) 0.5 kVAC 50 Hz
Ambient Temperature	0°C~+40°C (nonfreezing)
Ambient Humidity	85% or less (noncondensing)

Single-Phase 200-230 VAC

Item	Specification
Insulation Resistance	100 MΩ minimum when measured by a 500 VDC megger between the following places. • Motor case–Motor/Sensor windings • Motor case–Windings of electromagnetic brake (Only for electromagnetic brake equipped model)
Dielectric Strength	Sufficient to withstand the following for one minute. • Motor case–Motor/Sensor windings EZS3, EZS4: 1.0 kVAC 50 Hz EZS6: 1.5 kVAC 50 Hz • Motor case–Windings of electromagnetic brake (Only for electromagnetic brake equipped model) 0.5 kVAC 50 Hz
Ambient Temperature	0°C~+40°C (nonfreezing)
Ambient Humidity	85% or less (noncondensing)

Note:

- Do not measure insulation resistance or perform the dielectric strength test while the linear slide and controller are connected.

Safety Standards and CE Marking

Power Supply	Model	CE Marking
24 VDC	Linear slide	EMC Directives
	Controller	
Single-phase 200-230 VAC	Linear slide	Low Voltage Directive EMC Directives
	Controller	

- The EMC value changes according to the wiring and layout. Therefore, the final EMC level must be checked with the motor/driver incorporated in the user's equipment.

If you require EMC data of linear slides or controllers, please contact your nearest Oriental Motor office.

Machinery Directive (98/37/EC)

The linear slides, controllers and teaching pendants are designed and manufactured for use in general industrial equipment as an internal component, and therefore need not comply with the Machinery Directive. However, each product has been evaluated under the following standards to ensure proper operation:

EN ISO 12100-1, EN ISO 12100-2, EN 1050, EN 60204-1

Emergency Stop Function

The emergency stop circuits in the teaching pendant and controller are designed to the requirements under EN 954-1, Category 1.

See page 36 for a connection example that conforms to Stop Category 0 (non-controlled stop) under EN 60204-1.

Emergency Stop Circuit

The customer must provide an appropriate emergency stop circuit by conducting risk assessment based on your system.



Maintenance-Free for Long-Term Performance

The drive method uses THK's ball screw, while the guide mechanism adopts THK's LM Guide®. The ball screw employs the QZ™ lubrication system, while the LM Guide® uses the Ball Retainer® to retain the coupled rolling elements. These mechanisms give the system a considerable duration of maintenance-free performance.

- QZ™ lubrication system (THK): High-density fiber net supplies appropriate amounts of oil, thereby preventing oil wastage and reducing environmental burden.
- Ball Retainer® (THK): Individual balls are retained in a manner allowing smooth rotation while preventing contact with adjacent balls. Use of the Ball Retainer® provides long-term, maintenance-free operating conditions and other benefits.
- Ball Retainer and LM Guide are registered trademarks of THK Co., Ltd.

Order your linear slide with the necessary stroke

Range of selectable strokes: **50 to 850 mm**

EZS3, EZS4: 50 to 700 mm

EZS6: 50 to 850 mm

Each model is available with strokes specifiable in 50-mm increments.

(RoHS) RoHS-Compliant

The **EZSII** Series conforms to the RoHS Directive that prohibits the used of six chemical substances including lead and cadmium.

RoHS (Restriction of Hazardous Substances) Directive:

Directive on restriction of the use of certain hazardous substances in electrical and electronic equipment (2002/95/EC). The RoHS Directive prohibits the use of six chemical substances in electrical and electronic products sold in EU member states on or after July 1, 2006. The six controlled substances are: lead, hexavalent chromium, cadmium, mercury and two specific brominated flame-retardants (PBB and PBDE).

System Configuration

- Controller mode or Driver mode operating return to home operation with the **EZS II** Series controller.

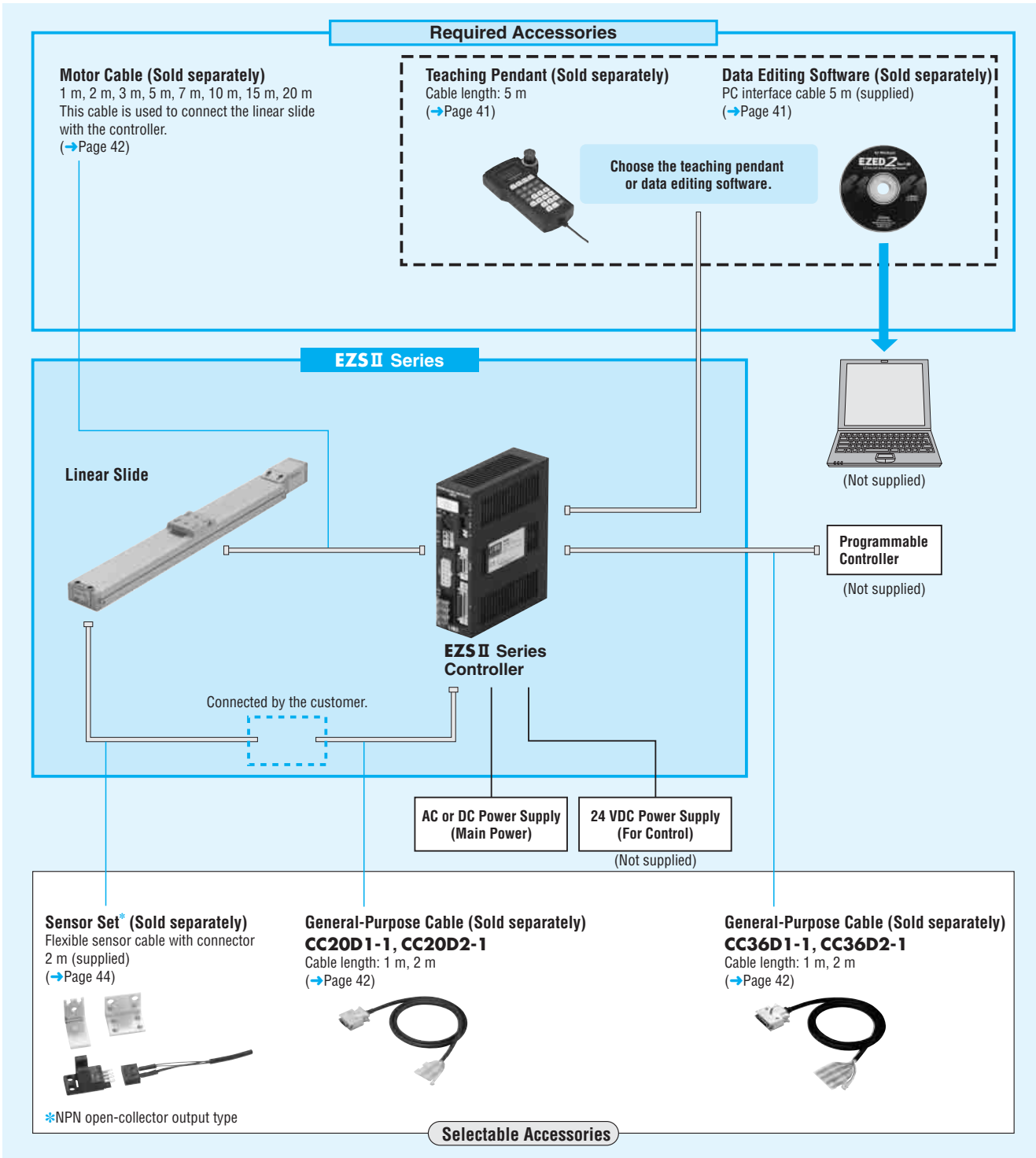

Example of System Configuration

(Body)

(Sold separately)

EZS II Series EZS3E005-C	+	Motor Cable (2 m)	Teaching Pendant	General-Purpose Cable (1 m)	General-Purpose Cable* (2 m)	Sensor Set*
		CC020ES-2	EZT1	CC36D1-1	CC20D2-1	PAES-S
		⊙	⊙	○	○	○

⊙ : Required under this system. ○ : Selectable according to necessity. Oriental Motor provides.

* Not required if return-to-home operation is performed without sensors.

- The system configuration shown above is an example. Other combinations are available.

● Driver mode operating return to home operation with the programmable controller

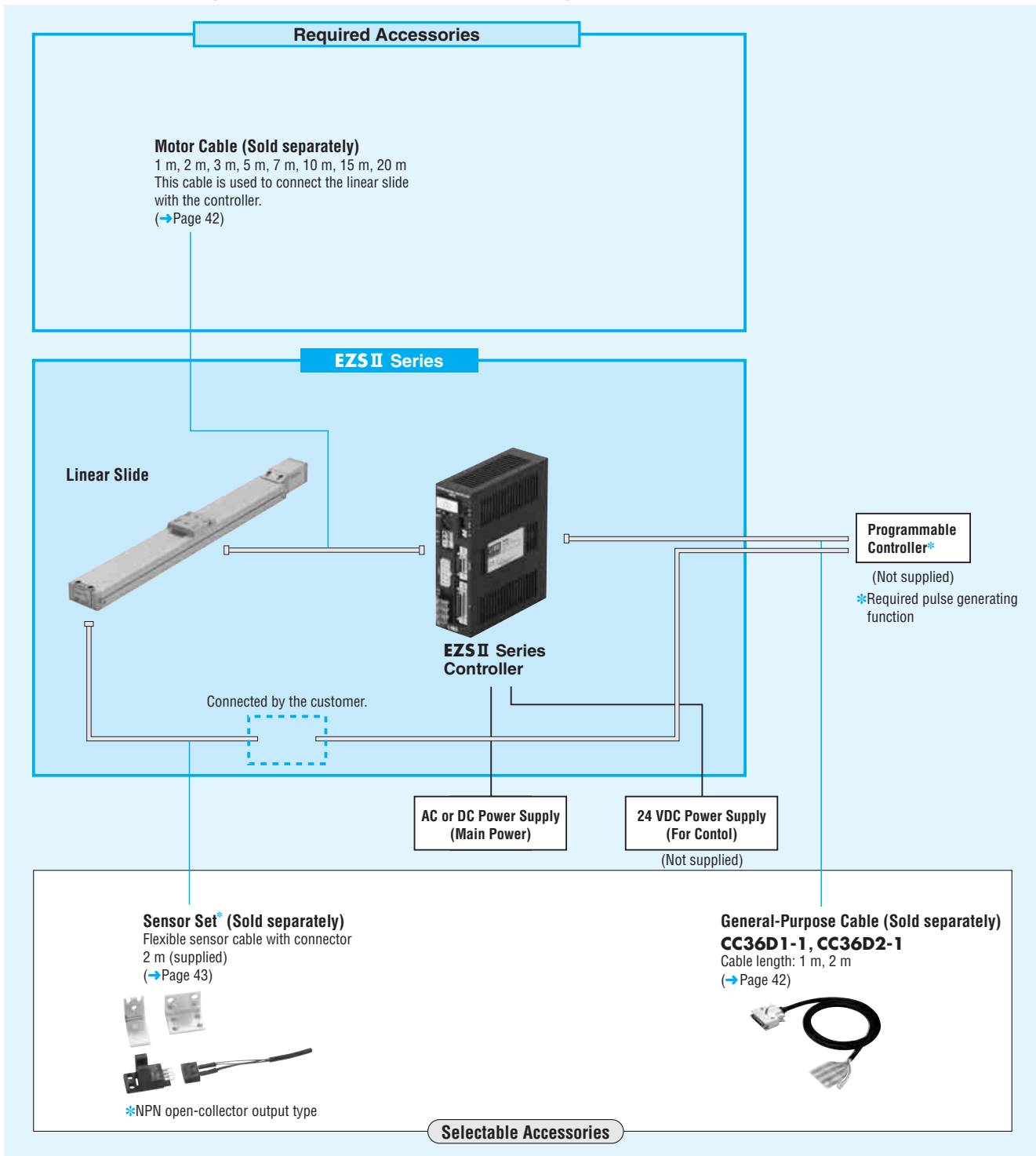

● Example of System Configuration

(Body)

(Sold separately)

EZS II Series EZS3E005-C	+	Motor Cable (2 m)	Sensor Set	General-Purpose Cable (1 m)
		CC020ES-2	PAES-S	CC36D1-1
		◎	○	○

◎ : Required under this system. ○ : Selectable according to necessity. Oriental Motor provides.

● The system configuration shown above is an example. Other combinations are available.

Note:

● Sensorless return to home operation is not available.

Product Number Code

EZS 3 D 050 M - K

① ② ③ ④ ⑤ ⑥

①	Series	EZS: EZSII Series		
②	Linear Slide Size	3 : Width: 54 mm Height: 50 mm		
		4 : Width: 74 mm Height: 50 mm		
		6 : Width: 74 mm Height: 66.5 mm		
③	Lead	D : 12 mm	E : 6 mm	
④	Stroke	005 : 50 mm	010 : 100 mm	015 : 150 mm
		020 : 200 mm	025 : 250 mm	030 : 300 mm
		035 : 350 mm	040 : 400 mm	045 : 450 mm
		050 : 500 mm	055 : 550 mm	060 : 600 mm
		065 : 650 mm	070 : 700 mm	075 : 750 mm
		080 : 800 mm	085 : 850 mm	
⑤	Electromagnetic Brake	None: Without Electromagnetic Brake M : With Electromagnetic Brake		
⑥	Power Supply Input	K : 24 VDC	C : Single-Phase 200-230 VAC	

Product Line

[In 50-mm Increments]

EZS3

Stroke	Without Electromagnetic Brake		With Electromagnetic Brake	
	24 VDC	Single-Phase 200-230 VAC	24 VDC	Single-Phase 200-230 VAC
	Model	Model	Model	Model
50 mm	EZS3□005-K	EZS3□005-C	EZS3□005M-K	EZS3□005M-C
100 mm	EZS3□010-K	EZS3□010-C	EZS3□010M-K	EZS3□010M-C
150 mm	EZS3□015-K	EZS3□015-C	EZS3□015M-K	EZS3□015M-C
200 mm	EZS3□020-K	EZS3□020-C	EZS3□020M-K	EZS3□020M-C
250 mm	EZS3□025-K	EZS3□025-C	EZS3□025M-K	EZS3□025M-C
300 mm	EZS3□030-K	EZS3□030-C	EZS3□030M-K	EZS3□030M-C
350 mm	EZS3□035-K	EZS3□035-C	EZS3□035M-K	EZS3□035M-C
400 mm	EZS3□040-K	EZS3□040-C	EZS3□040M-K	EZS3□040M-C
450 mm	EZS3□045-K	EZS3□045-C	EZS3□045M-K	EZS3□045M-C
500 mm	EZS3□050-K	EZS3□050-C	EZS3□050M-K	EZS3□050M-C
550 mm	EZS3□055-K	EZS3□055-C	EZS3□055M-K	EZS3□055M-C
600 mm	EZS3□060-K	EZS3□060-C	EZS3□060M-K	EZS3□060M-C
650 mm	EZS3□065-K	EZS3□065-C	EZS3□065M-K	EZS3□065M-C
700 mm	EZS3□070-K	EZS3□070-C	EZS3□070M-K	EZS3□070M-C

● The box (□) in the model name represents the lead length code of **D** (12 mm) or **E** (6 mm).

EZS4

Stroke	Without Electromagnetic Brake		With Electromagnetic Brake	
	24 VDC	Single-Phase 200-230 VAC	24 VDC	Single-Phase 200-230 VAC
	Model	Model	Model	Model
50 mm	EZS4□005-K	EZS4□005-C	EZS4□005M-K	EZS4□005M-C
100 mm	EZS4□010-K	EZS4□010-C	EZS4□010M-K	EZS4□010M-C
150 mm	EZS4□015-K	EZS4□015-C	EZS4□015M-K	EZS4□015M-C
200 mm	EZS4□020-K	EZS4□020-C	EZS4□020M-K	EZS4□020M-C
250 mm	EZS4□025-K	EZS4□025-C	EZS4□025M-K	EZS4□025M-C
300 mm	EZS4□030-K	EZS4□030-C	EZS4□030M-K	EZS4□030M-C
350 mm	EZS4□035-K	EZS4□035-C	EZS4□035M-K	EZS4□035M-C
400 mm	EZS4□040-K	EZS4□040-C	EZS4□040M-K	EZS4□040M-C
450 mm	EZS4□045-K	EZS4□045-C	EZS4□045M-K	EZS4□045M-C
500 mm	EZS4□050-K	EZS4□050-C	EZS4□050M-K	EZS4□050M-C
550 mm	EZS4□055-K	EZS4□055-C	EZS4□055M-K	EZS4□055M-C
600 mm	EZS4□060-K	EZS4□060-C	EZS4□060M-K	EZS4□060M-C
650 mm	EZS4□065-K	EZS4□065-C	EZS4□065M-K	EZS4□065M-C
700 mm	EZS4□070-K	EZS4□070-C	EZS4□070M-K	EZS4□070M-C

● The box (□) in the model name represents the lead length code of **D** (12 mm) or **E** (6 mm).

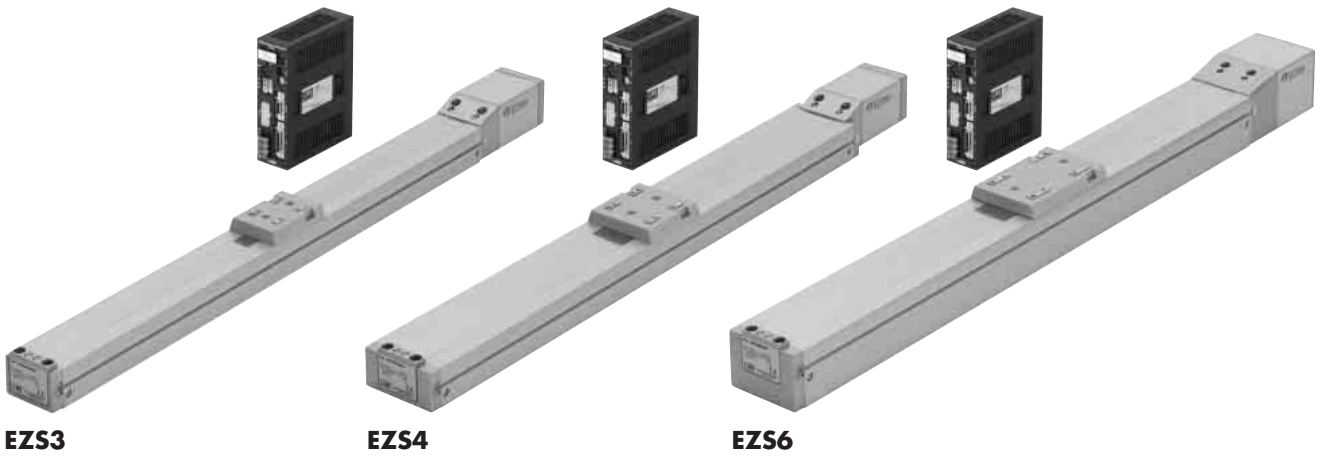

● EZS6

Stroke	Without Electromagnetic Brake		With Electromagnetic Brake	
	24 VDC	Single-Phase 200-230 VAC	24 VDC	Single-Phase 200-230 VAC
	Model	Model	Model	Model
50 mm	EZS6□005-K	EZS6□005-C	EZS6□005M-K	EZS6□005M-C
100 mm	EZS6□010-K	EZS6□010-C	EZS6□010M-K	EZS6□010M-C
150 mm	EZS6□015-K	EZS6□015-C	EZS6□015M-K	EZS6□015M-C
200 mm	EZS6□020-K	EZS6□020-C	EZS6□020M-K	EZS6□020M-C
250 mm	EZS6□025-K	EZS6□025-C	EZS6□025M-K	EZS6□025M-C
300 mm	EZS6□030-K	EZS6□030-C	EZS6□030M-K	EZS6□030M-C
350 mm	EZS6□035-K	EZS6□035-C	EZS6□035M-K	EZS6□035M-C
400 mm	EZS6□040-K	EZS6□040-C	EZS6□040M-K	EZS6□040M-C
450 mm	EZS6□045-K	EZS6□045-C	EZS6□045M-K	EZS6□045M-C
500 mm	EZS6□050-K	EZS6□050-C	EZS6□050M-K	EZS6□050M-C
550 mm	EZS6□055-K	EZS6□055-C	EZS6□055M-K	EZS6□055M-C
600 mm	EZS6□060-K	EZS6□060-C	EZS6□060M-K	EZS6□060M-C
650 mm	EZS6□065-K	EZS6□065-C	EZS6□065M-K	EZS6□065M-C
700 mm	EZS6□070-K	EZS6□070-C	EZS6□070M-K	EZS6□070M-C
750 mm	EZS6□075-K	EZS6□075-C	EZS6□075M-K	EZS6□075M-C
800 mm	EZS6□080-K	EZS6□080-C	EZS6□080M-K	EZS6□080M-C
850 mm	EZS6□085-K	EZS6□085-C	EZS6□085M-K	EZS6□085M-C

● The box (□) in the model name represents the lead length code of **D** (12 mm) or **E** (6 mm).

EZSII Series Adopting α STEP Motor, Rolled Ball Screw Specification

EZS3: 54 mm (W) × 50 mm (H), 24 VDC

Maximum Transportable Mass: Horizontal 15 kg / Vertical 7 kg
Stroke: 50 to 700 mm (in 50-mm increments)

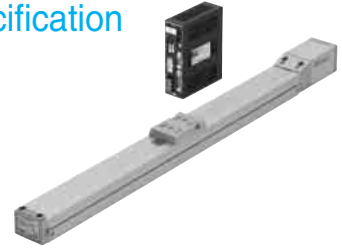

Specifications of Linear Slide (RoHS)



Drive Method	Rolled Ball Screw	Repetitive Positioning Accuracy [mm]	±0.02	Resolution [mm]	0.01	Traveling Parallelism [mm]	0.03*	Maximum Load Moment [N·m]	Mp: 4.2 Mv: 4.0 Mr: 10.5
Model	Lead [mm]	Transportable Mass [kg]		Maximum Speed (Stroke) [mm/s]				Thrust [N]	Electromagnetic Brake Holding Force [N]
		Horizontal	Vertical	50~550 mm	560~600 mm	610~650 mm	660~700 mm		
EZS3D□-K	12	~7.5	—	600	550	460	400	~43	—
EZS3D□M-K			~3.5						43
EZS3E□-K	6	~15	—	300	270	220	200	~86	—
EZS3E□M-K			~7						86

● The box (□) in the model name represents the code for stroke length.

*This applies when the linear slide is installed from the base surface.

Product Number Code

EZS 3 D 050 M - K

① ② ③ ④ ⑤ ⑥

①	Series EZS : EZSII Series
②	Linear Slide Size 3 : Width: 54 mm Height: 50 mm
③	Lead D : 12 mm E : 6 mm
④	Stroke 005 (50 mm)~ 070 (700 mm)
⑤	Electromagnetic Brake None: Without Electromagnetic Brake M : With Electromagnetic Brake
⑥	Power Supply Input K : 24 VDC

Linear Slide/Controller Combinations

Model names for linear slide and controller combinations are shown below.

Electromagnetic Brake	Model	Linear Slide Model	Controller Model
Not equipped	EZS3D □-K	EZSM3D□K	ESMC-K
	EZS3E □-K	EZSM3E□K	
Equipped	EZS3D □M-K	EZSM3D□MK	
	EZS3E □M-K	EZSM3E□MK	

● The box (□) in the model name represents the code for stroke length.

Positioning Distance – Positioning Time

Check the (approximate) positioning time from the positioning distance.

As a rough guideline, the positioning time by the linear slide corresponds to the positioning time calculated from the graph, multiplied by the positioning time coefficient corresponding to the applicable stroke.

●EZS3D (Lead: 12 mm)

◇Horizontal Installation

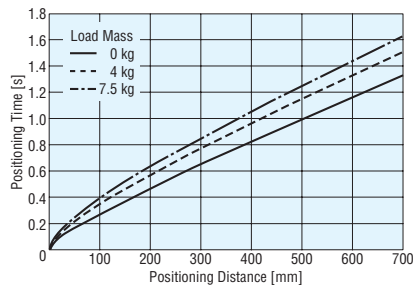

◇Vertical Installation

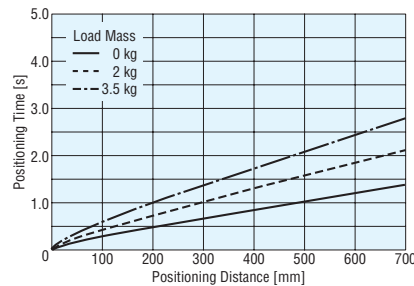

Positioning Time Coefficient

Stroke [mm]	Load Mass					
	Horizontal Installation			Vertical Installation		
	0 kg	4 kg	7.5 kg	0 kg	2 kg	3.5 kg
Stroke ≤ 550	1.0	1.0	1.0	1.0	1.0	1.0
560 ≤ stroke ≤ 600	1.0	1.0	1.0	1.0	1.0	1.0
610 ≤ stroke ≤ 650	1.2	1.1	1.1	1.2	1.0	1.0
660 ≤ stroke ≤ 700	1.4	1.2	1.2	1.3	1.0	1.0

●EZS3E (Lead: 6 mm)

◇Horizontal Installation

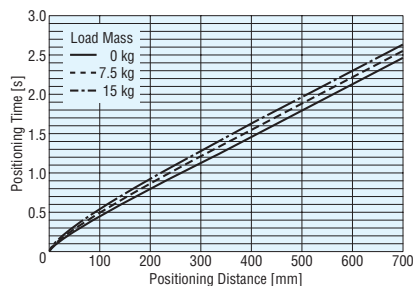

◇Vertical Installation

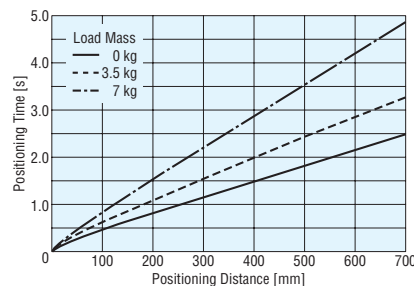

Positioning Time Coefficient

Stroke [mm]	Load Mass					
	Horizontal Installation			Vertical Installation		
	0 kg	7.5 kg	15 kg	0 kg	3.5 kg	7 kg
Stroke ≤ 550	1.0	1.0	1.0	1.0	1.0	1.0
560 ≤ stroke ≤ 600	1.1	1.1	1.1	1.1	1.0	1.0
610 ≤ stroke ≤ 650	1.3	1.3	1.2	1.3	1.0	1.0
660 ≤ stroke ≤ 700	1.4	1.4	1.4	1.4	1.1	1.0

Note:

● The positioning time in the graph does not include the setting time.
Use a settling time of 0.15 s as a reference.

■ Dimensions of Linear Slide (Unit = mm)

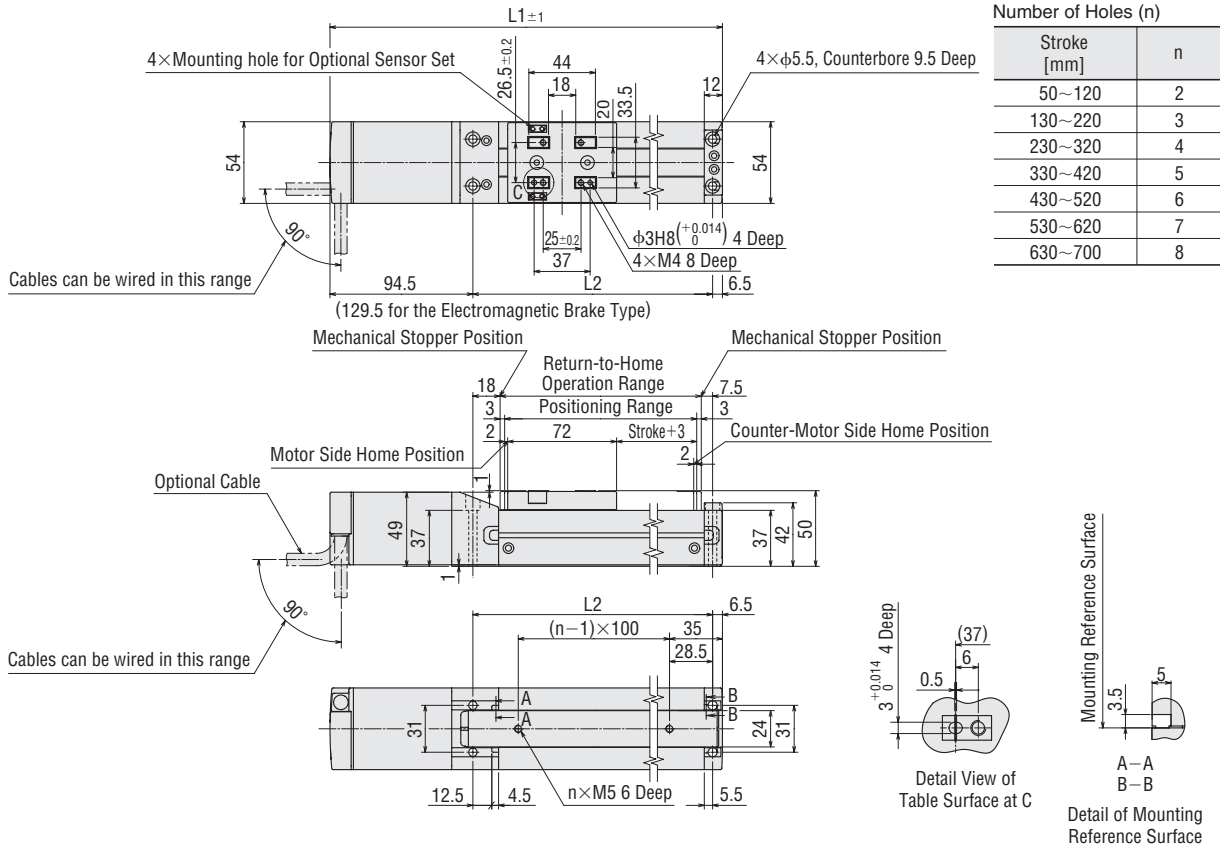

Linear Slide Model: EZSM3D□K, EZSM3E□K (Without Electromagnetic Brake)
EZSM3D□MK, EZSM3E□MK (With Electromagnetic Brake)

	Electromagnetic Brake	Numbers Specifiable in □ in Each Linear Slide Model Name														
		005	010	015	020	025	030	035	040	045	050	055	060	065	070	
Stroke	Not Equipped/Equipped	50	100	150	200	250	300	350	400	450	500	550	600	650	700	
L1	Not Equipped	259.5	309.5	359.5	409.5	459.5	509.5	559.5	609.5	659.5	709.5	759.5	809.5	859.5	909.5	
	Equipped	294.5	344.5	394.5	444.5	494.5	544.5	594.5	644.5	694.5	744.5	794.5	844.5	894.5	944.5	
L2	Not Equipped/Equipped	158.5	208.5	258.5	308.5	358.5	408.5	458.5	508.5	558.5	608.5	658.5	708.5	758.5	808.5	
Mass [kg]	Not Equipped	1.4	1.5	1.7	1.8	2.0	2.1	2.3	2.4	2.6	2.7	2.9	3.0	3.2	3.3	
	Equipped	1.6	1.7	1.9	2.0	2.2	2.3	2.5	2.6	2.8	2.9	3.1	3.2	3.4	3.5	

■ Dimensions for Linear Slide Installation (Unit = mm)

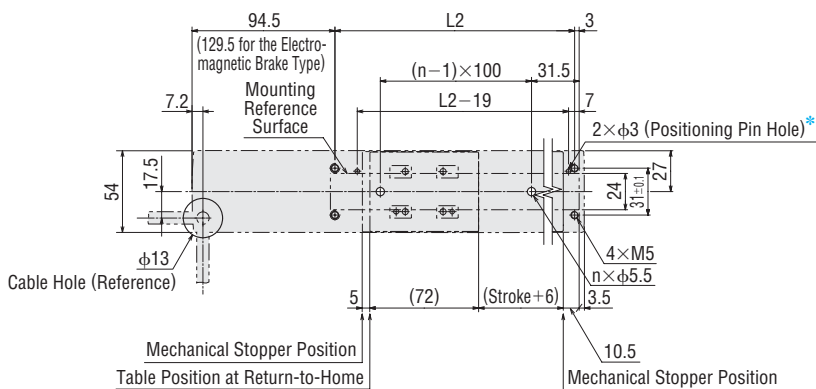

*The reference mounting plane can be set on either side.

The above figure assumes that the linear slide is mounted on its top surface.

EZSII Series Adopting α STEP Motor, Rolled Ball Screw Specification

EZS3: 54 mm (W) × 50 mm (H), Single-Phase 200-230 VAC

Maximum Transportable Mass: Horizontal 15 kg / Vertical 7 kg
Stroke: 50 to 700 mm (in 50-mm increments)

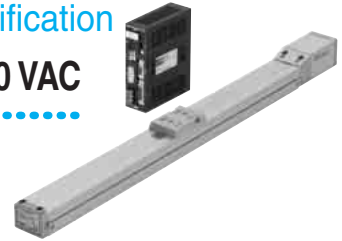

Specifications of Linear Slide (RoHS)



Drive Method	Rolled Ball Screw	Repetitive Positioning Accuracy [mm]	±0.02	Resolution [mm]	0.01	Traveling Parallelism [mm]	0.03*	Maximum Load Moment [N·m]	Mp: 4.2 Mv: 4.0 Mr: 10.5	
Model	Lead [mm]	Transportable Mass [kg]		Maximum Speed (Stroke) [mm/s]					Thrust [N]	Electromagnetic Brake Holding Force [N]
		Horizontal	Vertical	50~500 mm	510~550 mm	560~600 mm	610~650 mm	660~700 mm		
EZS3D□-C	12	~7.5	—	800	650	550	460	400	~43	—
EZS3D□M-C			~3.5							43
EZS3E□-C	6	~15	—	400	320	270	220	200	~86	—
EZS3E□M-C			~7							86

● The box (□) in the model name represents the code for stroke length.

*This applies when the linear slide is installed from the base surface.

Product Number Code

EZS 3 D 050 M - C

① ② ③ ④ ⑤ ⑥

①	Series EZS : EZSII Series
②	Linear Slide Size 3 : Width: 54 mm Height: 50 mm
③	Lead D : 12 mm E : 6 mm
④	Stroke 005 (50 mm) ~ 070 (700 mm)
⑤	Electromagnetic Brake None: Without Electromagnetic Brake M : With Electromagnetic Brake
⑥	Power Supply Input C : Single-Phase 200-230 VAC

Linear Slide/Controller Combinations

Model names for linear slide and controller combinations are shown below.

Electromagnetic Brake	Model	Linear Slide Model	Controller Model
Not equipped	EZS3D □-C	EZSM3D□C	ESMC-C
	EZS3E □-C	EZSM3E□C	
Equipped	EZS3D □M-C	EZSM3D□MC	
	EZS3E □M-C	EZSM3E□MC	

● The box (□) in the model name represents the code for stroke length.

Positioning Distance – Positioning Time

Check the (approximate) positioning time from the positioning distance.

As a rough guideline, the positioning time by the linear slide corresponds to the positioning time calculated from the graph, multiplied by the positioning time coefficient corresponding to the applicable stroke.

● EZS3D (Lead: 12 mm)

◇ Horizontal Installation

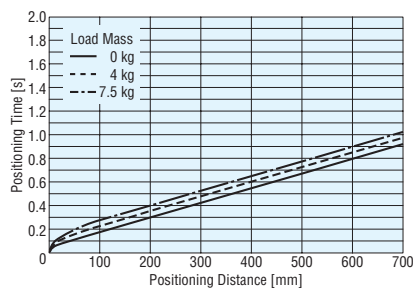

◇ Vertical Installation

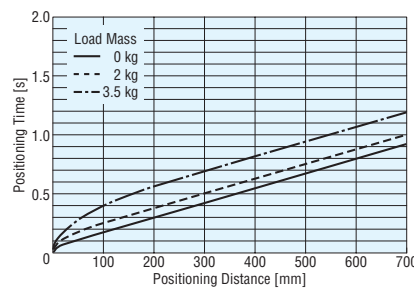

Positioning Time Coefficient

Stroke [mm]	Load Mass					
	Horizontal Installation			Vertical Installation		
	0 kg	4 kg	7.5 kg	0 kg	2 kg	3.5 kg
Stroke ≤ 500	1.0	1.0	1.0	1.0	1.0	1.0
510 ≤ stroke ≤ 550	1.2	1.2	1.2	1.2	1.2	1.1
560 ≤ stroke ≤ 600	1.4	1.4	1.3	1.4	1.3	1.2
610 ≤ stroke ≤ 650	1.7	1.6	1.4	1.7	1.6	1.4
660 ≤ stroke ≤ 700	1.9	1.8	1.6	1.9	1.8	1.6

● EZS3E (Lead: 6 mm)

◇ Horizontal Installation

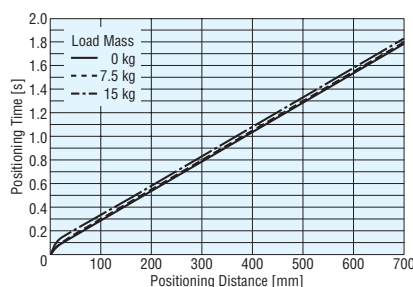

◇ Vertical Installation

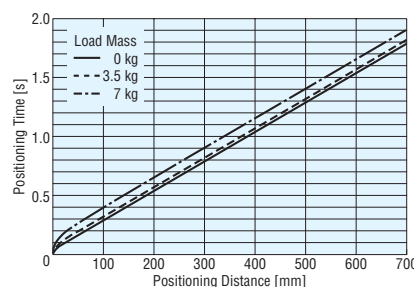

Positioning Time Coefficient

Stroke [mm]	Load Mass					
	Horizontal Installation			Vertical Installation		
	0 kg	7.5 kg	15 kg	0 kg	3.5 kg	7 kg
Stroke ≤ 500	1.0	1.0	1.0	1.0	1.0	1.0
510 ≤ stroke ≤ 550	1.2	1.2	1.2	1.2	1.2	1.2
560 ≤ stroke ≤ 600	1.5	1.4	1.4	1.5	1.4	1.4
610 ≤ stroke ≤ 650	1.8	1.8	1.8	1.8	1.8	1.7
660 ≤ stroke ≤ 700	2.0	1.9	1.9	2.0	1.9	1.9

Note:

● The positioning time in the graph does not include the setting time.
Use a settling time of 0.15 s as a reference.

■ Dimensions of Linear Slide (Unit = mm)

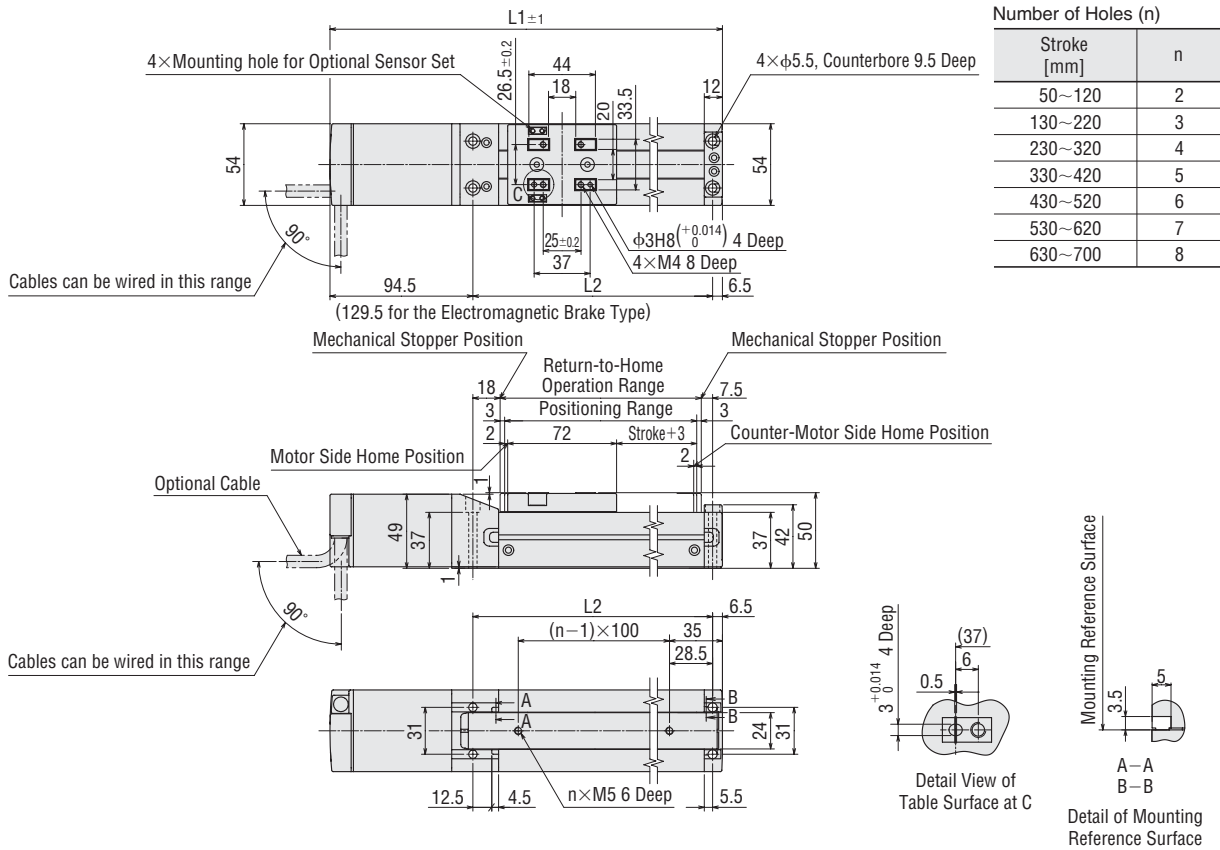

Linear Slide Model: EZSM3D□□, EZSM3E□□ (Without Electromagnetic Brake)
 EZSM3D□□MC, EZSM3E□□MC (With Electromagnetic Brake)

	Electromagnetic Brake	Numbers Specifiable in □ in Each Linear Slide Model Name														
		005	010	015	020	025	030	035	040	045	050	055	060	065	070	
Stroke	Not Equipped/Equipped	50	100	150	200	250	300	350	400	450	500	550	600	650	700	
L1	Not Equipped	259.5	309.5	359.5	409.5	459.5	509.5	559.5	609.5	659.5	709.5	759.5	809.5	859.5	909.5	
	Equipped	294.5	344.5	394.5	444.5	494.5	544.5	594.5	644.5	694.5	744.5	794.5	844.5	894.5	944.5	
L2	Not Equipped/Equipped	158.5	208.5	258.5	308.5	358.5	408.5	458.5	508.5	558.5	608.5	658.5	708.5	758.5	808.5	
Mass [kg]	Not Equipped	1.4	1.5	1.7	1.8	2.0	2.1	2.3	2.4	2.6	2.7	2.9	3.0	3.2	3.3	
	Equipped	1.6	1.7	1.9	2.0	2.2	2.3	2.5	2.6	2.8	2.9	3.1	3.2	3.4	3.5	

■ Dimensions for Linear Slide Installation (Unit = mm)

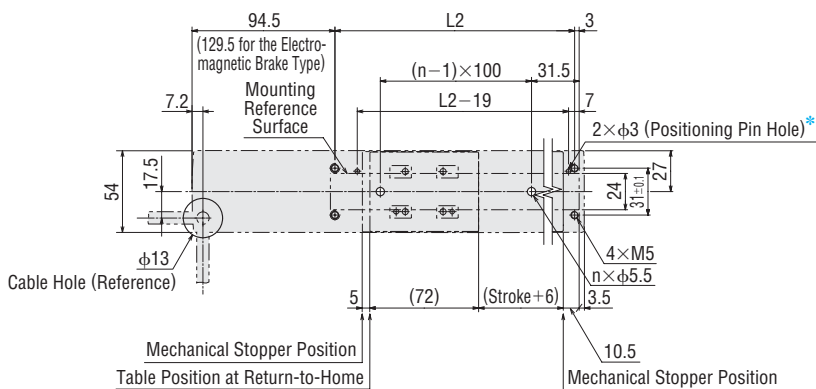

EZSII Series Adopting α STEP Motor, Rolled Ball Screw Specification

EZS4: 74 mm (W) × 50 mm (H), 24 VDC

Maximum Transportable Mass: Horizontal 30 kg / Vertical 14 kg
Stroke: 50 to 700 mm (in 50-mm increments)

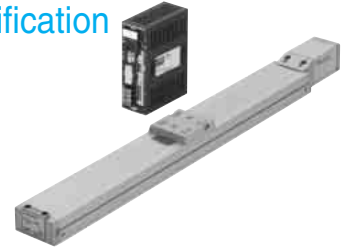

Specifications of Linear Slide (RoHS)



Drive Method	Rolled Ball Screw	Repetitive Positioning Accuracy [mm]	±0.02	Resolution [mm]	0.01	Traveling Parallelism [mm]	0.03*	Maximum Load Moment [N·m]	Mr: 8 Mv: 8 Ms: 27.8
--------------	-------------------	--------------------------------------	-------	-----------------	------	----------------------------	-------	---------------------------	----------------------

Model	Lead [mm]	Transportable Mass [kg]		Maximum Speed (Stroke) [mm/s]				Thrust [N]	Electromagnetic Brake Holding Force [N]
		Horizontal	Vertical	50~550 mm	560~600 mm	610~650 mm	660~700 mm		
EZS4D□-K	12	~15	—	600	550	460	400	~70	—
EZS4D□M-K			~7						70
EZS4E□-K	6	~30	—	300	270	220	200	~140	—
EZS4E□M-K			~14						140

● The box (□) in the model name represents the code for stroke length.

*This applies when the linear slide is installed from the base surface.

Product Number Code

EZS 4 D 050 M - K

① ② ③ ④ ⑤ ⑥

① Series EZS : EZSII Series
② Linear Slide Size 4 : Width: 74 mm Height: 50 mm
③ Lead D : 12 mm E : 6 mm
④ Stroke 050 (50 mm)~ 070 (700 mm)
⑤ Electromagnetic Brake None: Without Electromagnetic Brake M : With Electromagnetic Brake
⑥ Power Supply Input K : 24 VDC

Linear Slide/Controller Combinations

Model names for linear slide and controller combinations are shown below.

Electromagnetic Brake	Model	Linear Slide Model	Controller Model
Not equipped	EZS4D □-K	EZSM4D□K	ESMC-K
	EZS4E □-K	EZSM4E□K	
Equipped	EZS4D □M-K	EZSM4D□MK	
	EZS4E □M-K	EZSM4E□MK	

● The box (□) in the model name represents the code for stroke length.

Positioning Distance – Positioning Time

Check the (approximate) positioning time from the positioning distance.

As a rough guideline, the positioning time by the linear slide corresponds to the positioning time calculated from the graph, multiplied by the positioning time coefficient corresponding to the applicable stroke.

● EZS4D (Lead: 12 mm)

◇ Horizontal Installation

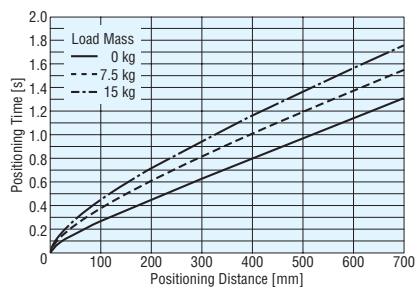

◇ Vertical Installation

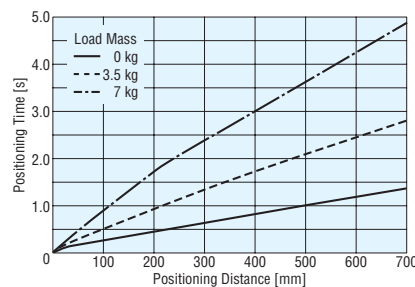

Positioning Time Coefficient

Stroke [mm]	Load Mass					
	Horizontal Installation			Vertical Installation		
	0 kg	7.5 kg	15 kg	0 kg	3.5 kg	7 kg
Stroke ≤ 550	1.0	1.0	1.0	1.0	1.0	1.0
560 ≤ stroke ≤ 600	1.0	1.0	1.0	1.0	1.0	1.0
610 ≤ stroke ≤ 650	1.2	1.1	1.0	1.2	1.0	1.0
660 ≤ stroke ≤ 700	1.4	1.1	1.1	1.3	1.0	1.0

● EZS4E (Lead: 6 mm)

◇ Horizontal Installation

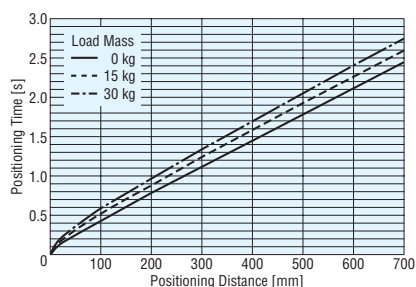

◇ Vertical Installation

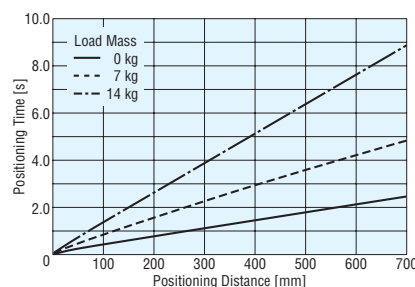

Positioning Time Coefficient

Stroke [mm]	Load Mass					
	Horizontal Installation			Vertical Installation		
	0 kg	15 kg	30 kg	0 kg	7 kg	14 kg
Stroke ≤ 550	1.0	1.0	1.0	1.0	1.0	1.0
560 ≤ stroke ≤ 600	1.1	1.1	1.0	1.1	1.0	1.0
610 ≤ stroke ≤ 650	1.3	1.3	1.2	1.3	1.0	1.0
660 ≤ stroke ≤ 700	1.4	1.4	1.3	1.4	1.0	1.0

Note:

● The positioning time in the graph does not include the setting time.
Use a settling time of 0.15 s as a reference.

■ Dimensions of Linear Slide (Unit = mm)

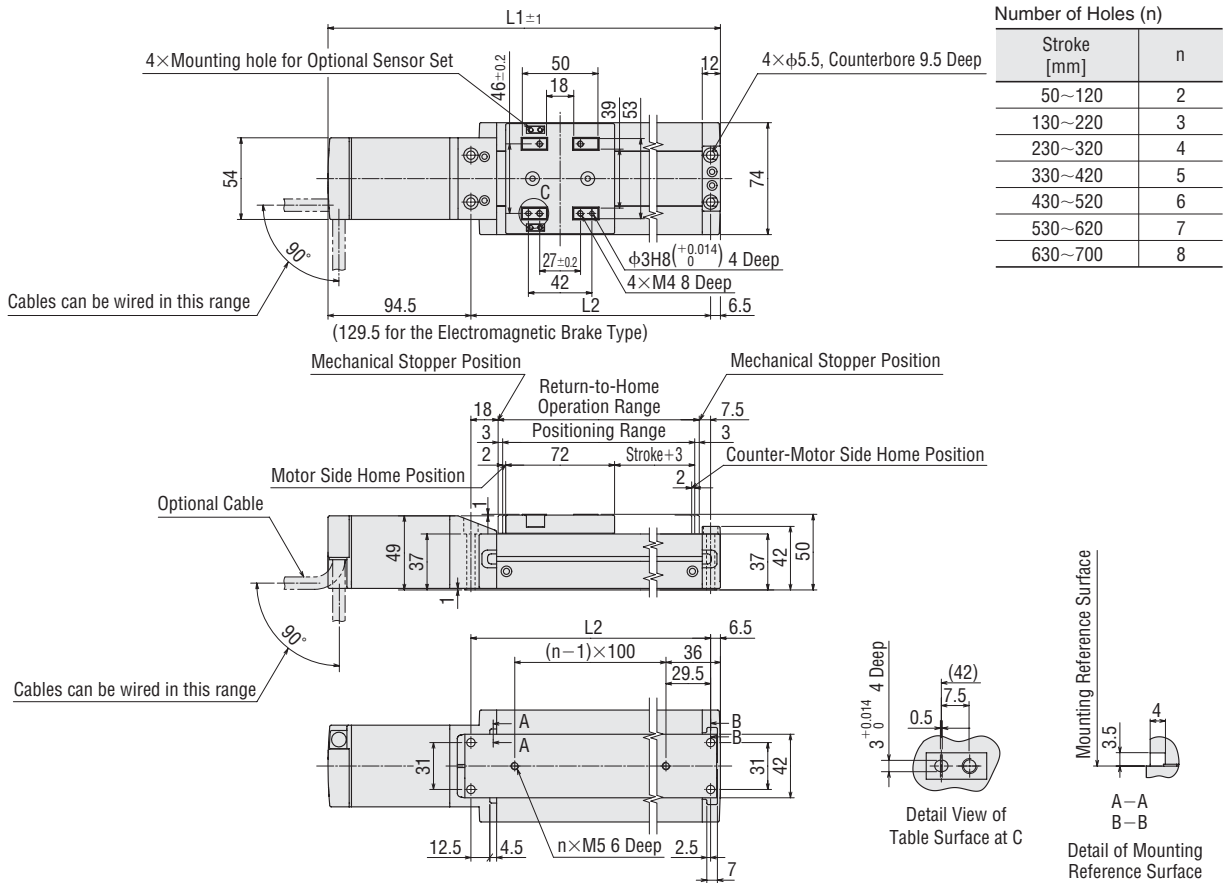

Linear Slide Model: EZSM4D□K, EZSM4E□K (Without Electromagnetic Brake)
 EZSM4D□MK, EZSM4E□MK (With Electromagnetic Brake)

	Electromagnetic Brake	Numbers Specifiable in □ in Each Linear Slide Model Name														
		005	010	015	020	025	030	035	040	045	050	055	060	065	070	
Stroke	Not Equipped/Equipped	50	100	150	200	250	300	350	400	450	500	550	600	650	700	
L1	Not Equipped	259.5	309.5	359.5	409.5	459.5	509.5	559.5	609.5	659.5	709.5	759.5	809.5	859.5	909.5	
	Equipped	294.5	344.5	394.5	444.5	494.5	544.5	594.5	644.5	694.5	744.5	794.5	844.5	894.5	944.5	
L2	Not Equipped/Equipped	158.5	208.5	258.5	308.5	358.5	408.5	458.5	508.5	558.5	608.5	658.5	708.5	758.5	808.5	
	Not Equipped	1.8	2.1	2.3	2.5	2.7	3.0	3.2	3.4	3.7	3.9	4.1	4.3	4.6	4.8	
Mass [kg]	Not Equipped	1.8	2.1	2.3	2.5	2.7	3.0	3.2	3.4	3.7	3.9	4.1	4.3	4.6	4.8	
	Equipped	2.0	2.3	2.5	2.7	2.9	3.2	3.4	3.6	3.9	4.1	4.3	4.5	4.8	5.0	

■ Dimensions for Linear Slide Installation (Unit = mm)

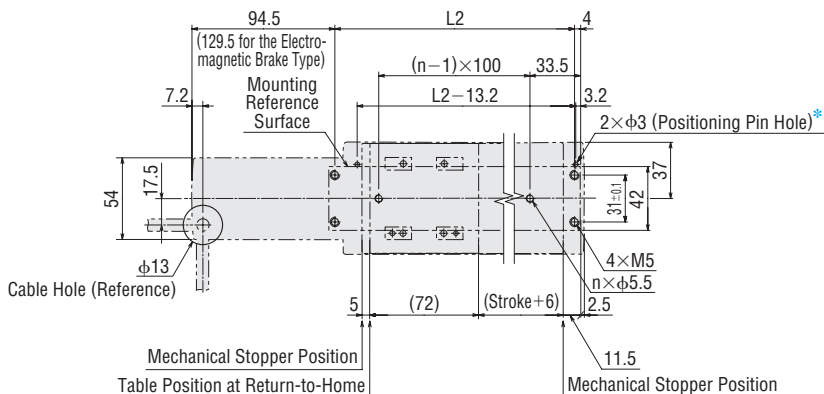

*The reference mounting plane can be set on either side.

The above figure assumes that the linear slide is mounted on its top surface.

EZSII Series Adopting α STEP Motor, Rolled Ball Screw Specification

EZS4: 74 mm (W) × 50 mm (H), Single-Phase 200-230 VAC

Maximum Transportable Mass: Horizontal 30 kg / Vertical 14 kg
Stroke: 50 to 700 mm (in 50-mm increments)

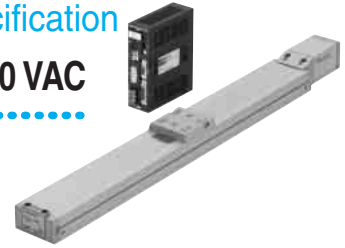

Specifications of Linear Slide (RoHS)



Drive Method	Rolled Ball Screw	Repetitive Positioning Accuracy [mm]	±0.02	Resolution [mm]	0.01	Traveling Parallelism [mm]	0.03*	Maximum Load Moment [N·m]	Mr: 8 Mv: 8 Mr: 27.8	
Model	Lead [mm]	Transportable Mass [kg]		Maximum Speed (Stroke) [mm/s]					Thrust [N]	Electromagnetic Brake Holding Force [N]
		Horizontal	Vertical	50~500 mm	510~550 mm	560~600 mm	610~650 mm	660~700 mm		
EZS4D□-C	12	~15	—	800	650	550	460	400	~70	—
EZS4D□M-C			~7							70
EZS4E□-C	6	~30	—	400	320	270	220	200	~140	—
EZS4E□M-C			~14							140

● The box (□) in the model name represents the code for stroke length.

*This applies when the linear slide is installed from the base surface.

Product Number Code

EZS 4 D 050 M - C

① ② ③ ④ ⑤ ⑥

- ① Series **EZS**: **EZSII** Series
- ② Linear Slide Size **4**: Width: 74 mm Height: 50 mm
- ③ Lead **D**: 12 mm **E**: 6 mm
- ④ Stroke **050** (50 mm)~**070** (700 mm)
- ⑤ Electromagnetic Brake None: Without Electromagnetic Brake
M: With Electromagnetic Brake
- ⑥ Power Supply Input **C**: Single-Phase 200-230 VAC

Linear Slide/Controller Combinations

Model names for linear slide and controller combinations are shown below.

Electromagnetic Brake	Model	Linear Slide Model	Controller Model
Not equipped	EZS4D□-C	EZSM4D□C	ESMC-C
	EZS4E□-C	EZSM4E□C	
Equipped	EZS4D□M-C	EZSM4D□MC	
	EZS4E□M-C	EZSM4E□MC	

● The box (□) in the model name represents the code for stroke length.

Positioning Distance – Positioning Time

Check the (approximate) positioning time from the positioning distance.

As a rough guideline, the positioning time by the linear slide corresponds to the positioning time calculated from the graph, multiplied by the positioning time coefficient corresponding to the applicable stroke.

●EZS4D (Lead: 12 mm)

◇Horizontal Installation

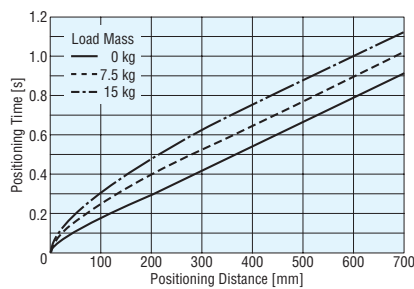

◇Vertical Installation

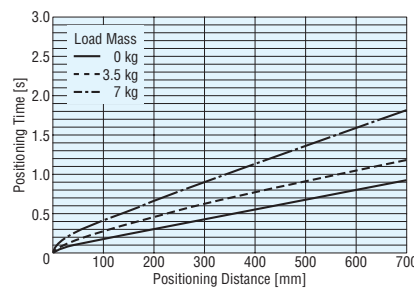

Positioning Time Coefficient

Stroke [mm]	Load Mass					
	Horizontal Installation			Vertical Installation		
	0 kg	7.5 kg	15 kg	0 kg	3.5 kg	7 kg
Stroke ≤ 500	1.0	1.0	1.0	1.0	1.0	1.0
510 ≤ stroke ≤ 550	1.2	1.1	1.1	1.2	1.0	1.0
560 ≤ stroke ≤ 600	1.4	1.3	1.2	1.4	1.1	1.0
610 ≤ stroke ≤ 650	1.7	1.5	1.4	1.7	1.3	1.0
660 ≤ stroke ≤ 700	1.9	1.8	1.6	1.9	1.5	1.0

●EZS4E (Lead: 6 mm)

◇Horizontal Installation

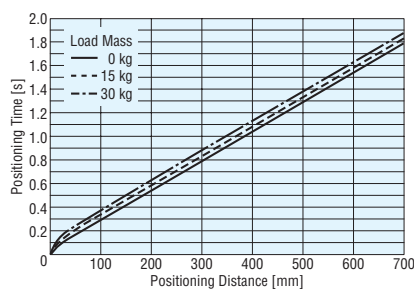

◇Vertical Installation

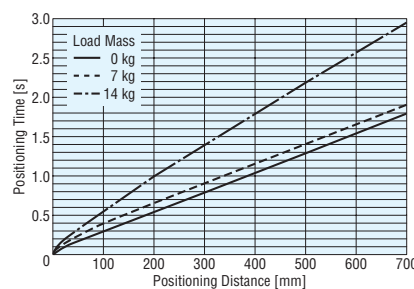

Positioning Time Coefficient

Stroke [mm]	Load Mass					
	Horizontal Installation			Vertical Installation		
	0 kg	15 kg	30 kg	0 kg	7 kg	14 kg
Stroke ≤ 500	1.0	1.0	1.0	1.0	1.0	1.0
510 ≤ stroke ≤ 550	1.2	1.2	1.2	1.2	1.2	1.0
560 ≤ stroke ≤ 600	1.5	1.4	1.4	1.5	1.4	1.0
610 ≤ stroke ≤ 650	1.8	1.7	1.7	1.8	1.7	1.1
660 ≤ stroke ≤ 700	2.0	1.9	1.9	2.0	1.9	1.2

Note:

- The positioning time in the graph does not include the setting time. Use a settling time of 0.15 s as a reference.

■ Dimensions of Linear Slide (Unit = mm)

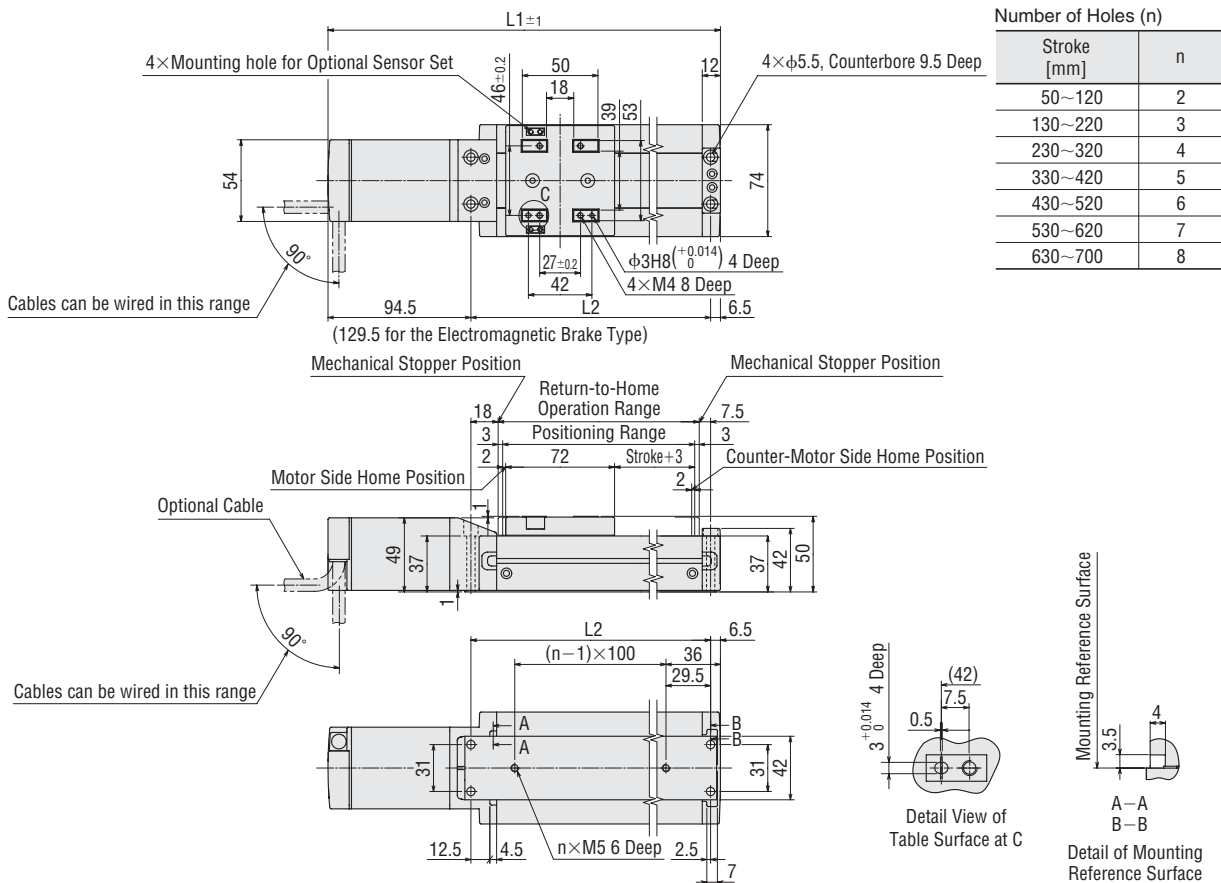

Linear Slide Model: EZSM4D□C, EZSM4E□C (Without Electromagnetic Brake)
 EZSM4D□MC, EZSM4E□MC (With Electromagnetic Brake)

	Electromagnetic Brake	Numbers Specifiable in □ in Each Linear Slide Model Name														
		005	010	015	020	025	030	035	040	045	050	055	060	065	070	
Stroke	Not Equipped/Equipped	50	100	150	200	250	300	350	400	450	500	550	600	650	700	
L1	Not Equipped	259.5	309.5	359.5	409.5	459.5	509.5	559.5	609.5	659.5	709.5	759.5	809.5	859.5	909.5	
	Equipped	294.5	344.5	394.5	444.5	494.5	544.5	594.5	644.5	694.5	744.5	794.5	844.5	894.5	944.5	
L2	Not Equipped/Equipped	158.5	208.5	258.5	308.5	358.5	408.5	458.5	508.5	558.5	608.5	658.5	708.5	758.5	808.5	
	Not Equipped	1.8	2.1	2.3	2.5	2.7	3.0	3.2	3.4	3.7	3.9	4.1	4.3	4.6	4.8	
Mass [kg]	Not Equipped	1.8	2.1	2.3	2.5	2.7	3.0	3.2	3.4	3.7	3.9	4.1	4.3	4.6	4.8	
	Equipped	2.0	2.3	2.5	2.7	2.9	3.2	3.4	3.6	3.9	4.1	4.3	4.5	4.8	5.0	

■ Dimensions for Linear Slide Installation (Unit = mm)

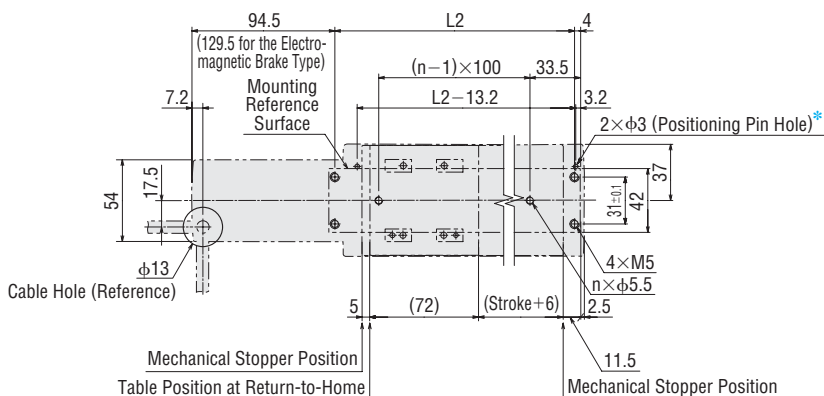

*The reference mounting plane can be set on either side.

The above figure assumes that the linear slide is mounted on its top surface.

EZSII Series Adopting α STEP Motor, Rolled Ball Screw Specification

EZS6: 74 mm (W) × 66.5 mm (H), 24 VDC

Maximum Transportable Mass: Horizontal 60 kg / Vertical 30 kg
Stroke: 50 to 850 mm (in 50-mm increments)

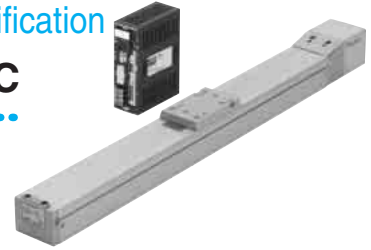

Specifications of Linear Slide (RoHS)



Drive Method	Rolled Ball Screw	Repetitive Positioning Accuracy [mm]	±0.02	Resolution [mm]	0.01	Traveling Parallelism [mm]	0.03*	Maximum Load Moment [N·m]	Mp: 45.7 Mv: 12.5 Mr: 55.6	
Model	Lead [mm]	Transportable Mass [kg]		Maximum Speed (Stroke) [mm/s]					Thrust [N]	Electromagnetic Brake Holding Force [N]
		Horizontal	Vertical	50~650 mm	660~700 mm	710~750 mm	760~800 mm	810~850 mm		
EZS6D□-K	12	~30	—	600	550	470	420	360	~184	—
EZS6D□M-K			~15							184
EZS6E□-K	6	~60	—	300	260	230	200	180	~369	—
EZS6E□M-K			~30							369

● The box (□) in the model name represents the code for stroke length.

*This applies when the linear slide is installed from the base surface.

Product Number Code

EZS 6 D 050 M - K

① ② ③ ④ ⑤ ⑥

①	Series EZS : EZSII Series
②	Linear Slide Size 6 : Width: 74 mm Height: 66.5 mm
③	Lead D : 12 mm E : 6 mm
④	Stroke 050 (50 mm)~ 085 (850 mm)
⑤	Electromagnetic Brake None: Without Electromagnetic Brake M : With Electromagnetic Brake
⑥	Power Supply Input K : 24 VDC

Linear Slide/Controller Combinations

Model names for linear slide and controller combinations are shown below.

Electromagnetic Brake	Model	Linear Slide Model	Controller Model
Not equipped	EZS6D □-K	EZSM6D□K	ESMC-K
	EZS6E □-K	EZSM6E□K	
Equipped	EZS6D □M-K	EZSM6D□MK	
	EZS6E □M-K	EZSM6E□MK	

● The box (□) in the model name represents the code for stroke length.

Positioning Distance – Positioning Time

Check the (approximate) positioning time from the positioning distance.

As a rough guideline, the positioning time by the linear slide corresponds to the positioning time calculated from the graph, multiplied by the positioning time coefficient corresponding to the applicable stroke.

● EZS6D (Lead: 12 mm)

◇ Horizontal Installation

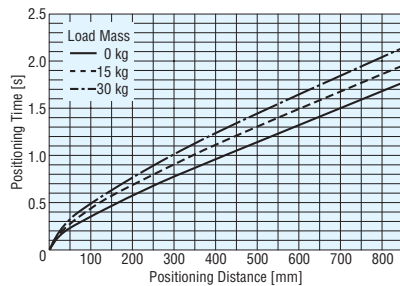

◇ Vertical Installation

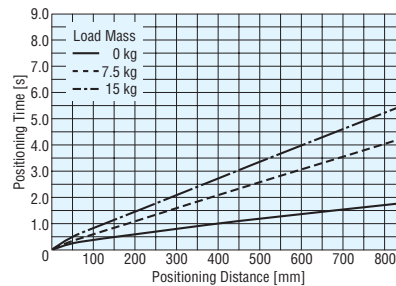

Positioning Time Coefficient

Stroke [mm]	Load Mass					
	Horizontal Installation			Vertical Installation		
	0 kg	15 kg	30 kg	0 kg	7.5 kg	15 kg
Stroke ≤ 650	1.0	1.0	1.0	1.0	1.0	1.0
660 ≤ stroke ≤ 700	1.0	1.0	1.0	1.0	1.0	1.0
710 ≤ stroke ≤ 750	1.1	1.1	1.0	1.1	1.0	1.0
760 ≤ stroke ≤ 800	1.2	1.1	1.1	1.2	1.0	1.0
810 ≤ stroke ≤ 850	1.4	1.3	1.2	1.4	1.0	1.0

● EZS6E (Lead: 6 mm)

◇ Horizontal Installation

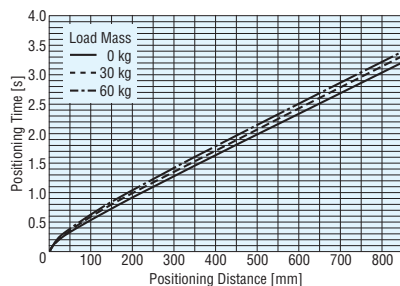

◇ Vertical Installation

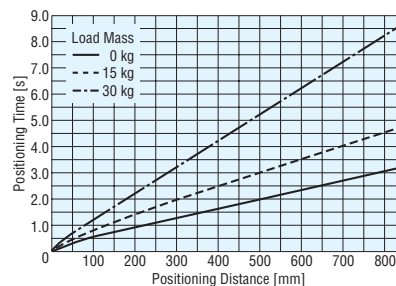

Positioning Time Coefficient

Stroke [mm]	Load Mass					
	Horizontal Installation			Vertical Installation		
	0 kg	30 kg	60 kg	0 kg	15 kg	30 kg
Stroke ≤ 650	1.0	1.0	1.0	1.0	1.0	1.0
660 ≤ stroke ≤ 700	1.1	1.0	1.0	1.5	1.0	1.0
710 ≤ stroke ≤ 750	1.2	1.2	1.1	1.5	1.0	1.0
760 ≤ stroke ≤ 800	1.3	1.3	1.3	1.3	1.0	1.0
810 ≤ stroke ≤ 850	1.5	1.5	1.4	1.5	1.0	1.0

Note:

● The positioning time in the graph does not include the setting time.
Use a settling time of 0.15 s as a reference.

Dimensions of Linear Slide (Unit = mm)

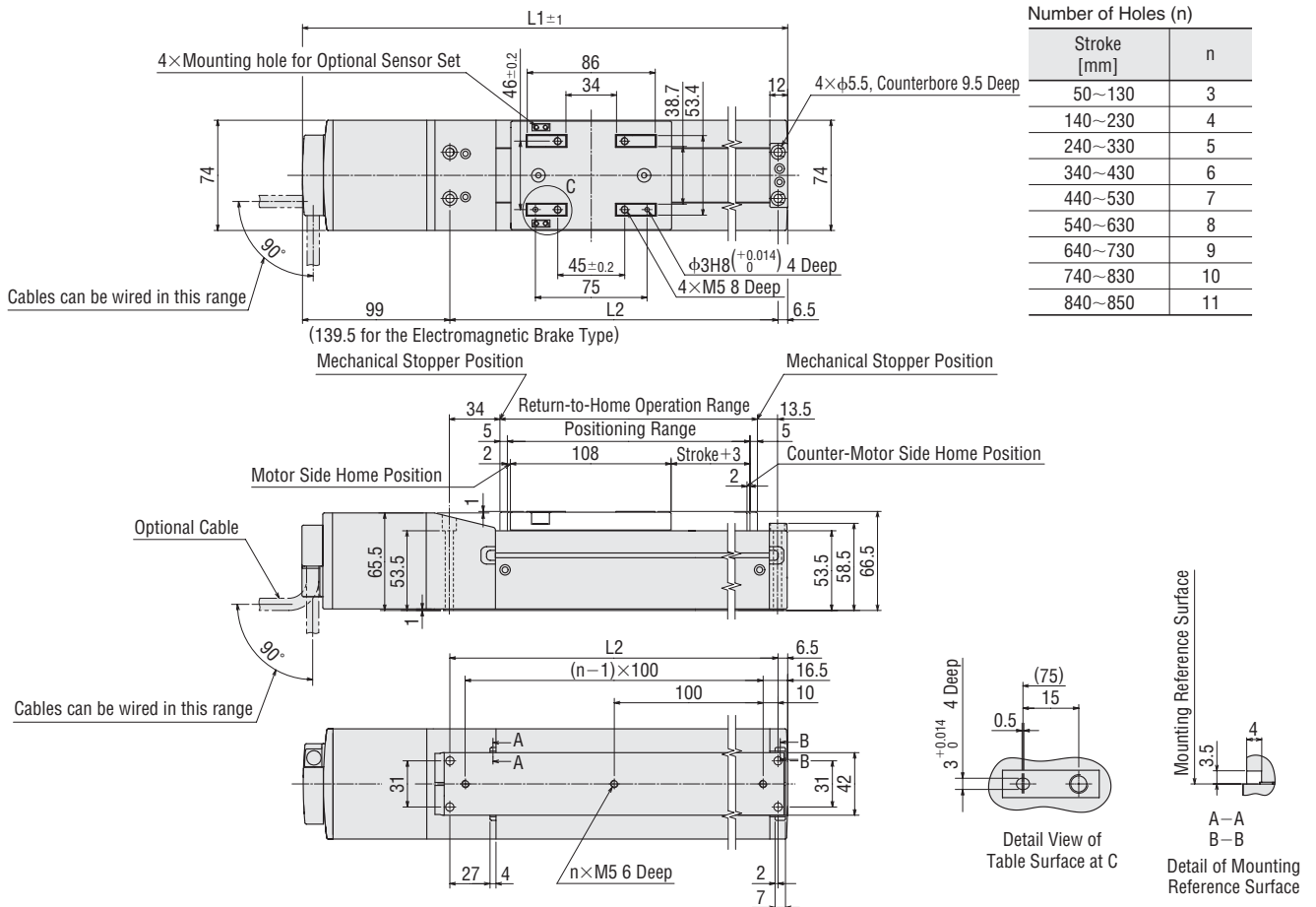

Linear Slide Model: EZSM6D□K, EZSM6E□K (Without Electromagnetic Brake)
EZSM6D□MK, EZSM6E□MK (With Electromagnetic Brake)

	Electromagnetic Brake	Numbers Specifiable in □ in Each Linear Slide Model Name																
		005	010	015	020	025	030	035	040	045	050	055	060	065	070	075	080	085
Stroke	Not Equipped/Equipped	50	100	150	200	250	300	350	400	450	500	550	600	650	700	750	800	850
	Not Equipped	326	376	426	476	526	576	626	676	726	776	826	876	926	976	1026	1076	1126
L1	Equipped	366.5	416.5	466.5	516.5	566.5	616.5	666.5	716.5	766.5	816.5	866.5	916.5	966.5	1016.5	1067	1117	1166.5
	Not Equipped/Equipped	220.5	270.5	320.5	370.5	420.5	470.5	520.5	570.5	620.5	670.5	720.5	770.5	820.5	870.5	920.5	970.5	1020.5
Mass [kg]	Not Equipped	3.4	3.6	3.9	4.1	4.4	4.7	4.9	5.2	5.4	5.7	6.0	6.2	6.5	6.7	7.0	7.3	7.5
	Equipped	3.8	4.0	4.3	4.5	4.8	5.1	5.3	5.6	5.8	6.1	6.4	6.6	6.9	7.1	7.4	7.7	7.9

Dimensions for Linear Slide Installation (Unit = mm)

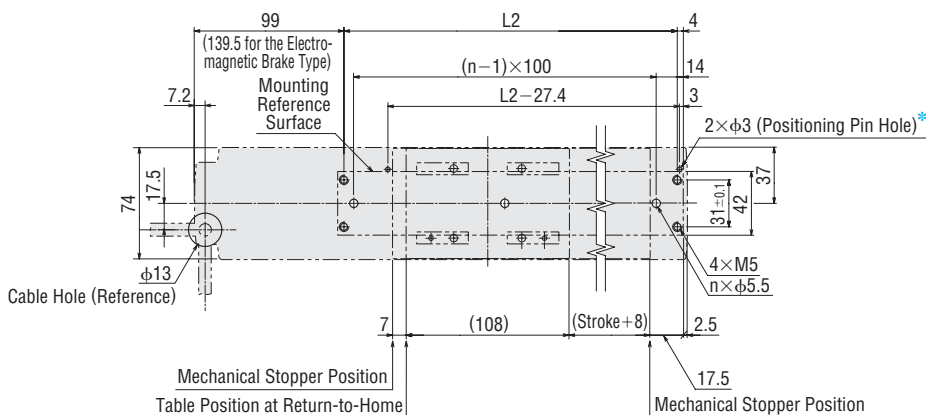

EZSII Series Adopting α STEP Motor, Rolled Ball Screw Specification

EZS6: 74 mm (W) × 66.5 mm (H), Single-Phase 200-230 VAC

Maximum Transportable Mass: Horizontal 60 kg / Vertical 30 kg
Stroke: 50 to 850 mm (in 50-mm increments)

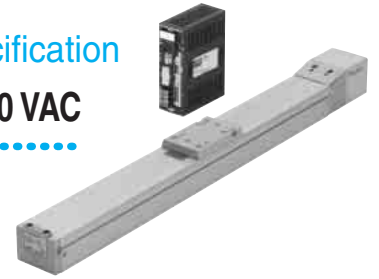

Specifications of Linear Slide (RoHS)



Drive Method	Rolled Ball Screw	Repetitive Positioning Accuracy [mm]	±0.02	Resolution [mm]	0.01	Traveling Parallelism [mm]	0.03*	Maximum Load Moment [N·m]	Mp: 45.7 Mv: 12.5 Mr: 55.6		
Model	Lead [mm]	Transportable Mass [kg]		Maximum Speed (Stroke) [mm/s]						Thrust [N]	Electromagnetic Brake Holding Force [N]
		Horizontal	Vertical	50~550 mm	560~600 mm	610~650 mm	660~700 mm	710~750 mm	760~800 mm		
EZS6D□-C	12	~30	—	800	640	550	470	420	360	~184	—
EZS6D□M-C			~15								184
EZS6E□-C	6	~60	—	400	350	300	260	230	200	~369	—
EZS6E□M-C			~30								369

● The box (□) in the model name represents the code for stroke length.

*This applies when the linear slide is installed from the base surface.

Product Number Code

EZS 6 D 050 M - C

① ② ③ ④ ⑤ ⑥

①	Series EZS : EZSII Series
②	Linear Slide Size 6 : Width: 74 mm Height: 66.5 mm
③	Lead D : 12 mm E : 6 mm
④	Stroke 005 (50 mm)~ 085 (850 mm)
⑤	Electromagnetic Brake None: Without Electromagnetic Brake M : With Electromagnetic Brake
⑥	Power Supply Input C : Single-Phase 200-230 VAC

Linear Slide/Controller Combinations

Model names for linear slide and controller combinations are shown below.

Electromagnetic Brake	Model	Linear Slide Model	Controller Model
Not equipped	EZS6D □-C	EZSM6D□C	ESMC-C
	EZS6E □-C	EZSM6E□C	
Equipped	EZS6D □M-C	EZSM6D□MC	
	EZS6E □M-C	EZSM6E□MC	

● The box (□) in the model name represents the code for stroke length.

Positioning Distance – Positioning Time

Check the (approximate) positioning time from the positioning distance.

As a rough guideline, the positioning time by the linear slide corresponds to the positioning time calculated from the graph, multiplied by the positioning time coefficient corresponding to the applicable stroke.

●EZS6D (Lead: 12 mm)

◇Horizontal Installation

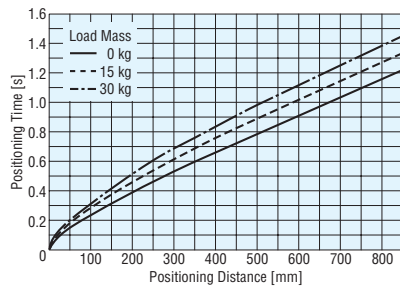

◇Vertical Installation

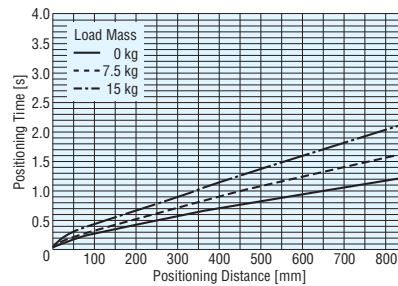

Positioning Time Coefficient

Stroke [mm]	Load Mass					
	Horizontal Installation			Vertical Installation		
	0 kg	15 kg	30 kg	0 kg	7.5 kg	15 kg
Stroke ≤ 600	1.0	1.0	1.0	1.0	1.0	1.0
610 ≤ stroke ≤ 650	1.1	1.1	1.0	1.1	1.0	1.0
660 ≤ stroke ≤ 700	1.3	1.2	1.1	1.3	1.0	1.0
710 ≤ stroke ≤ 750	1.5	1.4	1.3	1.5	1.2	1.0
760 ≤ stroke ≤ 800	1.7	1.5	1.4	1.7	1.3	1.1
810 ≤ stroke ≤ 850	2.0	1.8	1.7	2.4	1.5	1.2

●EZS6E (Lead: 6 mm)

◇Horizontal Installation

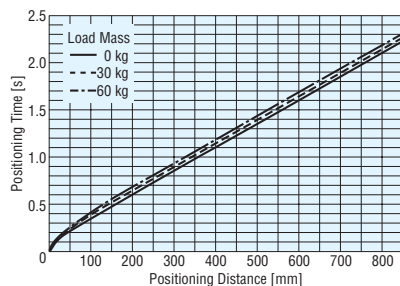

◇Vertical Installation

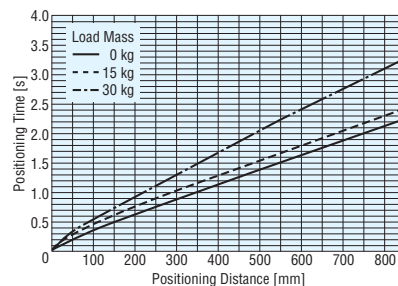

Positioning Time Coefficient

Stroke [mm]	Load Mass					
	Horizontal Installation			Vertical Installation		
	0 kg	30 kg	60 kg	0 kg	15 kg	30 kg
Stroke ≤ 600	1.0	1.0	1.0	1.0	1.0	1.0
610 ≤ stroke ≤ 650	1.1	1.1	1.1	1.1	1.1	1.0
660 ≤ stroke ≤ 700	1.3	1.3	1.3	1.3	1.2	1.0
710 ≤ stroke ≤ 750	1.5	1.5	1.4	1.5	1.4	1.0
760 ≤ stroke ≤ 800	1.7	1.6	1.6	1.7	1.5	1.2
810 ≤ stroke ≤ 850	1.9	1.9	1.9	1.9	1.8	1.3

Note:

● The positioning time in the graph does not include the setting time.
Use a settling time of 0.15 s as a reference.

Dimensions of Linear Slide (Unit = mm)

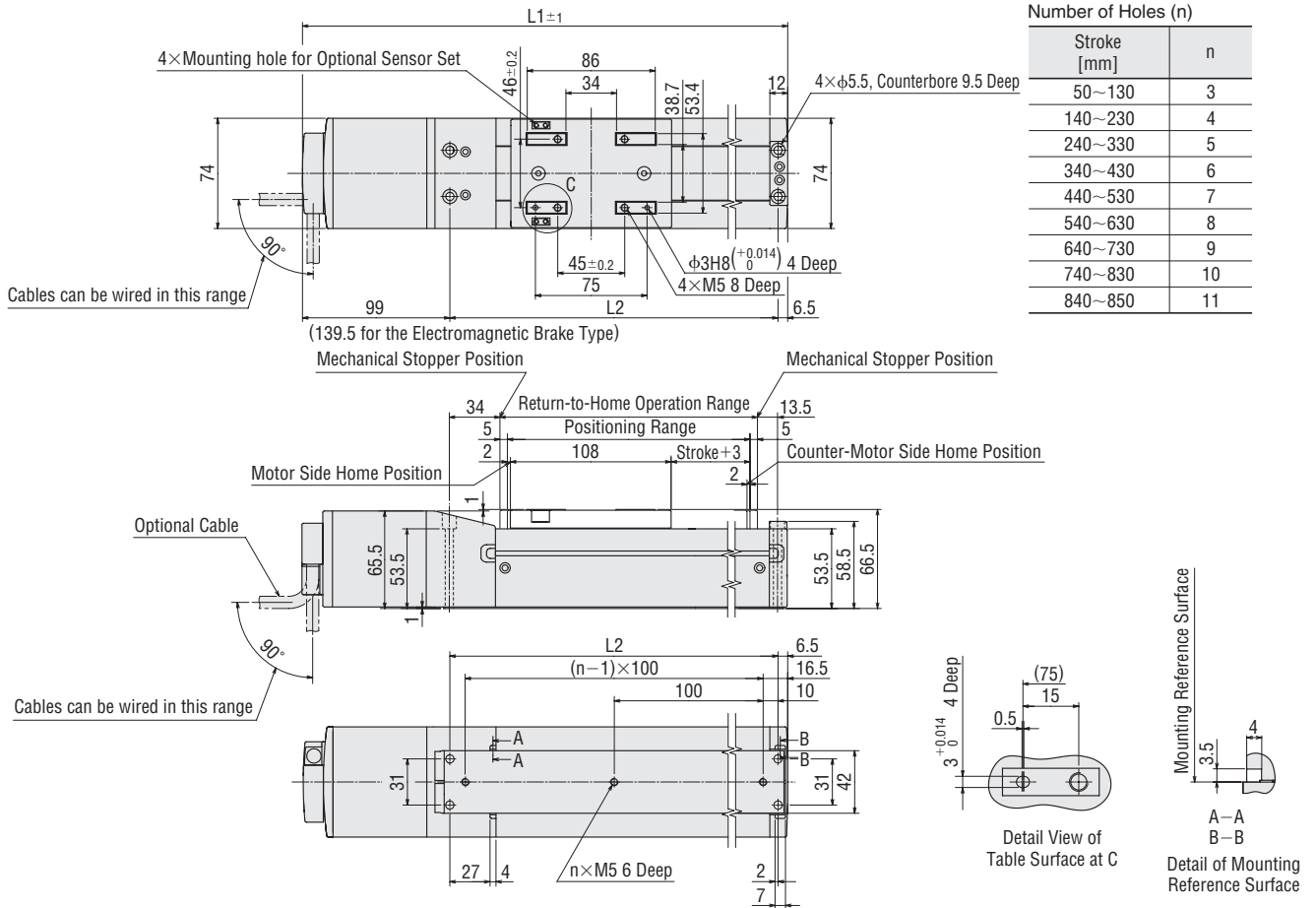

Linear Slide Model: EZSM6D□C, EZSM6E□C (Without Electromagnetic Brake)
EZSM6D□MC, EZSM6E□MC (With Electromagnetic Brake)

	Electromagnetic Brake	Numbers Specifiable in □ in Each Linear Slide Model Name																
		005	010	015	020	025	030	035	040	045	050	055	060	065	070	075	080	085
Stroke	Not Equipped/Equipped	50	100	150	200	250	300	350	400	450	500	550	600	650	700	750	800	850
	Not Equipped	326	376	426	476	526	576	626	676	726	776	826	876	926	976	1026	1076	1126
L1	Equipped	366.5	416.5	466.5	516.5	566.5	616.5	666.5	716.5	766.5	816.5	866.5	916.5	966.5	1016.5	1067	1117	1166.5
	Not Equipped/Equipped	220.5	270.5	320.5	370.5	420.5	470.5	520.5	570.5	620.5	670.5	720.5	770.5	820.5	870.5	920.5	970.5	1020.5
Mass [kg]	Not Equipped	3.4	3.6	3.9	4.1	4.4	4.7	4.9	5.2	5.4	5.7	6.0	6.2	6.5	6.7	7.0	7.3	7.5
	Equipped	3.8	4.0	4.3	4.5	4.8	5.1	5.3	5.6	5.8	6.1	6.4	6.6	6.9	7.1	7.4	7.7	7.9

Dimensions for Linear Slide Installation (Unit = mm)

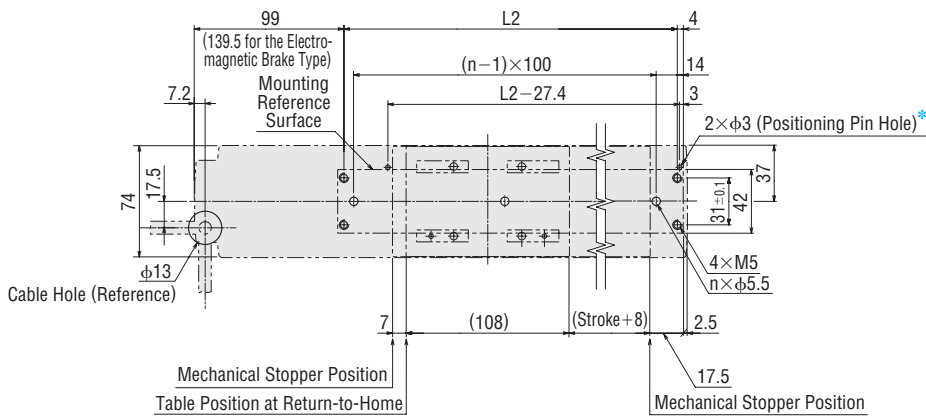

Specifications of Controller

Controller Mode

Item	Controller Model		
	ESMC-K	ESMC-C	
Type	Stored-data type		
Power Supply Input	Control Power	24 VDC±5% 1.0 A [Controller only: 0.5 A (Take into account safety margin of +0.2 A for the teaching pendant, and/or +0.3 A for the electromagnetic brake type.)]	
	Main Power	Voltage	24 VDC±10%
		Frequency	—
		Current	4.0 A*
Positioning Data	Setting Mode	Absolute mode (absolute-position specification), Incremental mode (relative-position specification)	
	Number	63	
	Setting Method	Data is set using the teaching pendant (EZT1) or data editing software (EZED2) (Stored in EEPROM)	
Positioning Control	Mode	Selective positioning Sequential positioning	
	Travel Amount Setting Range	−83886.08~+83886.07 mm (value set in units of 0.01 mm)	
	Starting Speed	0.01~200.00 mm/s (value set in units of 0.01 mm/s)	
	Operating Speed	0.01~800.00 mm/s (value set in units of 0.01 mm/s)	
	Acceleration/Deceleration	0.01~20.00 m/s ² (value set in units of 0.01 m/s ²)	
Control Mode	<ul style="list-style-type: none"> External input mode (EXT): In this mode, operation by external signal, command position, I/O condition and alarm condition can be monitored. Program mode (PRG): In this mode, operation data can be created, changed or cleared. Parameter mode (PAR): In this mode, operation parameters and function setting parameters can be set or changed. Test mode (TST): In this mode, manual operation and I/O check can be performed. 		
Operation Mode	Positioning operation, Return-to-home operation, Linked operation (a maximum of 4 data), Continuous operation		
Input Signal/Input Mode	START, STOP, HOME/PRESET, FREE, M0~M5, REQ, ACL/CK 24 VDC Photocoupler insulation input, Input resistance 4.7 kΩ FWD, RVS 5 VDC Photocoupler insulation input, Input resistance 180 kΩ or 24 VDC Photocoupler insulation input, Input resistance 2.7 kΩ +LS, −LS, HOMELS 24 VDC Photocoupler insulation input, Input resistance 4.7 kΩ		
Output Signal/Output Mode	ALM, END/OUTR, MOVE, AREA/OUT0, OUT1 Photocoupler, Open-collector output (24 VDC, 10 mA or less) ASG1, BSG1 Photocoupler, Open-collector output (24 VDC, 15 mA or less) ASG2, BSG2 Line-driver output		
Protective Function	Excessive position deviation, Overcurrent protection, Overvoltage protection, Overheat protection, Overload, Motor overheat protection, Sensor error, Overspeed, Nonvolatile memory error, etc.		
Indicators (LED)	PWR, ALM	PWR, ALM, CHARGE	
Cooling Method	Natural ventilation		
Mass	0.48 kg	0.75 kg	

Driver Mode

Item	Controller Model		
	ESMC-K	ESMC-C	
Power Supply Input	Control Power	24 VDC±5% 1.0 A [Controller only: 0.5 A (Take into account safety margin of +0.2 A for the teaching pendant, and/or +0.3 A for the electromagnetic brake type.)]	
	Main Power	Voltage	24 VDC±10%
		Frequency	—
		Current	4.0 A*
Maximum Response Frequency	1-pulse input mode, 2-pulse input mode: 80 kHz, Phase difference input mode: 20 kHz		
Operation Mode	Return-to-home operation, Pulse input operation (1-pulse input mode, 2-pulse input mode, Phase difference input mode)		
Input Signal/Input Mode	ACL/CK, FREE, C.OFF, HOME/PRESET, REQ 24 VDC Photocoupler insulation input, Input resistance 4.7 kΩ FP, RP 5 VDC Photocoupler insulation input, Input resistance 180 kΩ or 24 VDC Photocoupler insulation input, Input resistance 2.7 kΩ +LS, −LS, HOMELS 24 VDC Photocoupler insulation input, Input resistance 4.7 kΩ		
Output Signal/Output Mode	MOVE, END/OUTR, ALM, TIM/OUT0, OUT Photocoupler, Open-collector output (24 VDC, 10 mA or less) ASG1, BSG1 Photocoupler, Open-collector output (24 VDC, 15 mA or less) ASG2, BSG2 Line-driver output		
Protective Function	Excessive position deviation, Overcurrent protection, Overvoltage protection, Overheat protection, Overload, Motor overheat protection, Sensor error, Overspeed, Nonvolatile memory error, etc.		
Indicators (LED)	PWR, ALM	PWR, ALM, CHARGE	
Cooling Method	Natural ventilation		
Mass	0.48 kg	0.75 kg	

* The maximum current varies depending on the connected linear slide.

[ESMC-K] EZSM3/EZSM4: 1.7 A EZSM6: 4.0 A

[ESMC-C] EZSM3/EZSM4: 2.1 A EZSM6: 3.0 A

General Specifications of Controller

This is the value after rated operation at normal temperature and normal humidity.

24 VDC

Item	Specification
Insulation Resistance	100 MΩ minimum when measured by a 500 VDC megger between the following places: · FG – Main power supply · FG – I/O Connector
Dielectric Strength	Sufficient to withstand the following for one minute: · FG – Main power supply 0.5 kVAC 50 Hz · FG – I/O Connector 0.5 kVAC 50 Hz
Ambient Temperature	0°C ~ +40°C (nonfreezing)
Ambient Humidity	85% or below (noncondensing)

Note:

- Do not measure insulation resistance or perform the dielectric strength test while the motor and driver are connected.

Single-Phase 200-230 VAC

Item	Specification
Insulation Resistance	100 MΩ minimum when measured by a 500 VDC megger between the following places: · I/O Connector – Main power supply, Motor connector, Battery connector · Control power supply – Main power supply, Motor connector, Battery connector · PE – Main power supply, Motor connector, Battery connector
Dielectric Strength	Sufficient to withstand the following for one minute: · Signal I/O, Control power supply – Main power supply 1.8 kV · Signal I/O, Control power supply – Motor output 1.8 kV · Signal I/O, Control power supply – Battery input 1.8 kV · PE – Main power supply 1.5 kV · PE – Motor output 1.5 kV · PE – Battery input 1.5 kV
Ambient Temperature	0°C ~ +40°C (nonfreezing)
Ambient Humidity	85% or below (noncondensing)

Controller Dimensions (Unit = mm)

24 VDC

Controller Model: ESMC-K

Mass: 0.48 kg

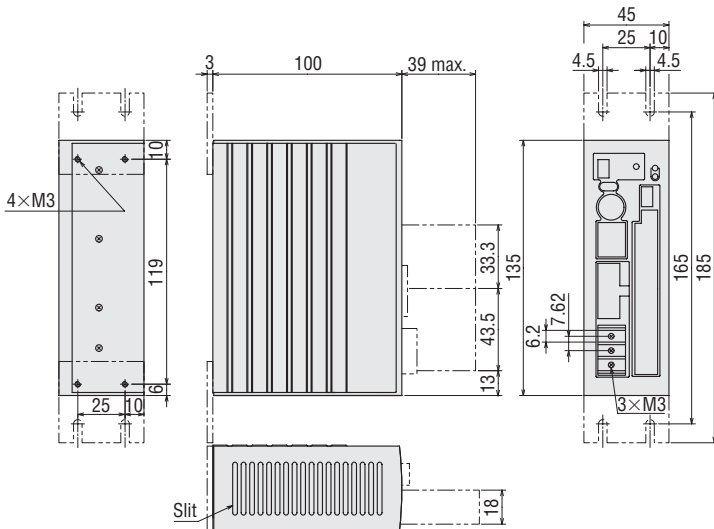

Mounting Bracket (Included) (2 pieces)

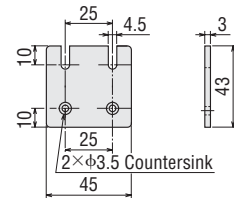

I/O Connector (Included)
 Case: 54331-1361 (MOLEX)
 Connector: 54306-3619 (MOLEX)
 I/O Connector for Sensor (Included)
 Case: 54331-1201 (MOLEX)
 Connector: 54306-2019 (MOLEX)

Single-Phase 200-230 VAC

Controller Model: ESMC-C

Mass: 0.75kg

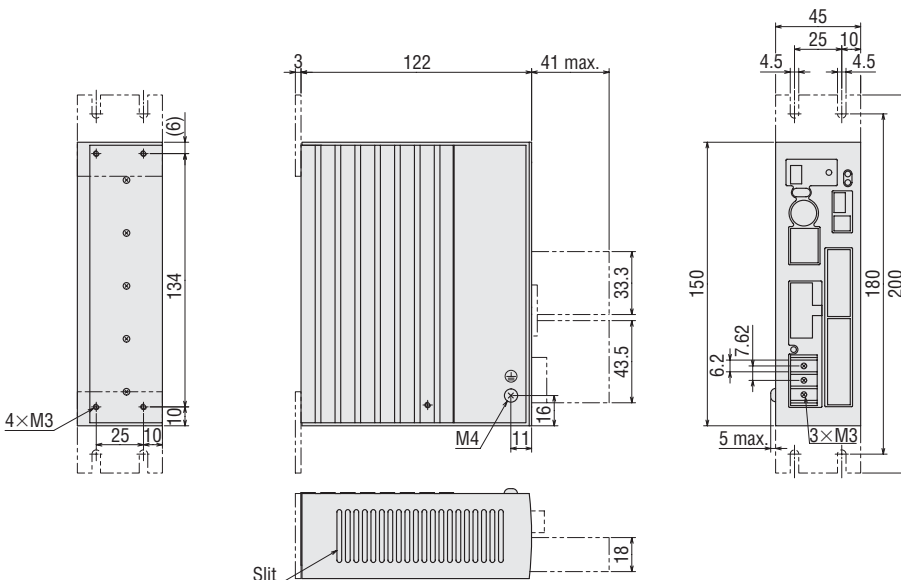

Mounting Bracket (Included) (2 pieces)

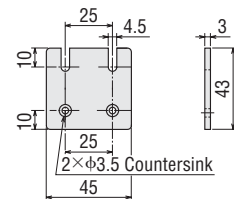

I/O Connector (Included)
 Case: 54331-1361 (MOLEX)
 Connector: 54306-3619 (MOLEX)
 I/O Connector for Sensor (Included)
 Case: 54331-1201 (MOLEX)
 Connector: 54306-2019 (MOLEX)

■ Connection and Operation

● Names and Functions of Controller

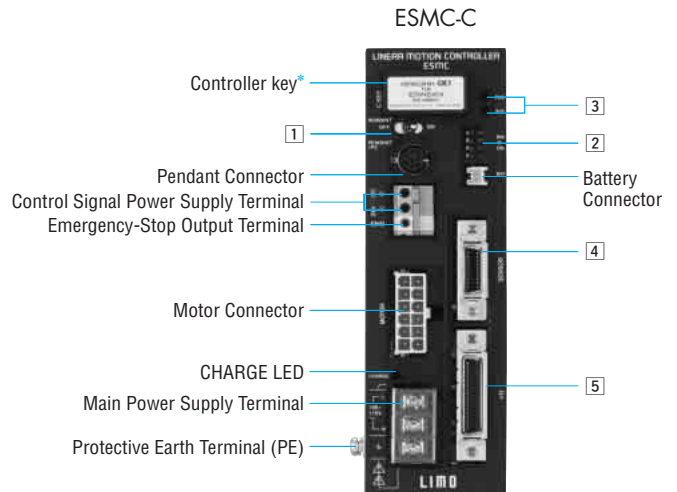
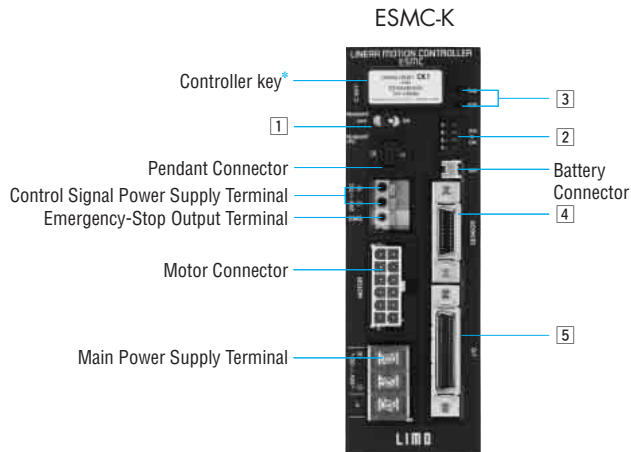

1 Pendant Switch

Indication	Function
PENDANT	Enable/disable the teaching pendant. ON: Enable the teaching pendant OFF: Disable the teaching pendant (The emergency stop button on the teaching pendant is also disabled.)

2 Mode Switch

Indication	Function
4	Invalid (not used)
3	Switch ABS/INC ON: Absolute Type OFF: Incremental Type
2	Set Pulse Input Mode (in driver mode) ON: 1-Pulse Input Mode OFF: 2-Pulse Input Mode
1	Switch Modes ON: Driver Mode OFF: Controller Mode

3 LED Indicator

Indication	Color	Name
PWR	Green	Control power supply indicator
ALM	Red	Alarm indicator

4 Sensor Connector

Indication	Input	Pin Number	Terminal Name	Function
SENSOR	Input	1	IN-COM2	Power supply for sensor
		11		
		19		
		13	+LS	+coordinate limit sensor
		14	-LS	-coordinate limit sensor
		15	HOMELS	Mechanical home sensor

* Make sure the linear slide component name on the controller key matches the component name of the connected linear slide. If the names do not match, the linear slide cannot be operated as specified.

5 I/O Connector

● Controller Mode

Indication	I/O	Terminal Number	Terminal Name	Function	
I/O	Input	18	IN-COM1 ^{*1*}	Power supply input for input signals	
		19	I/O-GND	Power supply GND for I/O	
		1	OUT-COM ^{*3}	Power supply input for output signals	
	Output	2	ALM	Output when an alarm has occurred (contact B)	
		3	MOVE	Output while the motorized linear slide is operating	
		4	END/OUTR ^{*4}	END: Output while the rotor has stopped at a position within $\pm 1.8^\circ$ of the command position at the end of the current position OUTR: Used to read the current position	
		5	AREA/OUTO ^{*4}	AREA: Output when the moving part has entered the specified area or stopped inside the area OUTO: Used to read the current position	
		6	T-UP/OUT1 ^{*4}	T-UP: Output when a push-motion operation has been completed OUT1: Used to read the current position	
		20	ASG1	A-phase pulse output (Open-collector)	
		21	BAG1	B-phase pulse output (Open-collector)	
		22	ASG2	A-phase pulse output (Line driver)	
		23	ASG2		
		24	BSG2	B-phase pulse output (Line driver)	
		25	BSG2		
		Input	7	START	Positioning Start
			8	ACL/CK ^{*4}	ACL: Alarm clear CK: Used to read the current position
			9	FREE	Stop the excitation of the motorized linear slide to release the electromagnetic brake
	10		STOP	Operating stop	
	11		M0	Operating No. selection	
	12		M1		
	13		M2		
	14		M3		
	15		M4		
	16		M5		
	17		HOME/PRESET ^{*5}	HOME: Starts return-to-home operation PRESET: Presets the current position	
	30		REQ	ABS data request	
	31		FWD+	Continuous operation in the + coordinate direction	
	32		FWD-		
	33		P24-FWD		
	34		RVS+	Continuous operation in the - coordinate direction	
	35		RVS-		
	36		P24-RVS		

*1 Connect this signal to 24 VDC if your controller is used in the NPN mode, or connect it to ground if the controller is used in the PNP mode.

*2 Connect this signal even when only output signals are used.

*3 Connect this signal to ground if your controller is used in the NPN mode, or connect it to 24 VDC if the controller is used in the PNP mode.

*4 If the REQ input is ON, these signals switch to the OUTR output, OUTO output, OUT1 output and CK input, respectively. If the REQ input is OFF, they switch the END output, AREA output, T-UP output and ACL input, respectively.

*5 Switch between the HOME and PRESET using the I/O parameter "HOME/PRESET switching"

● Driver Mode

Indication	I/O	Terminal Number	Terminal Name	Function	
I/O	Input	18	IN-COM1 ^{*1*}	Power supply input for input signals	
		19	I/O-GND	Power supply GND for I/O	
		1	OUT-COM ^{*3}	Power supply input for output signals	
	Output	2	ALM	Output when an alarm has occurred (contact B)	
		3	MOVE	Output while the motorized linear slide is operating	
		4	END/OUTR ^{*4}	END: Output while the rotor has stopped at a position within $\pm 1.8^\circ$ of the command position at the end of the current position OUTR: Used to read the current position	
		5	TIM/OUTO ^{*4}	TIM: Output when the excitation sequence is at step 0 OUTO: Used to read the current position	
		6	T-UP/OUT1 ^{*4}	T-UP: Output when a push-motion operation has been completed OUT1: Used to read the current position	
		20	ASG1	A-phase pulse output (Open-collector)	
		21	BAG1	B-phase pulse output (Open-collector)	
		22	ASG2	A-phase pulse output (Line driver)	
		23	ASG2		
		24	BSG2	B-phase pulse output (Line driver)	
		25	BSG2		
		Input	8	ACL/CK ^{*4}	ACL: Alarm clear CK: Used to read the current position
			9	FREE	Stop the excitation of the motorized linear slide to release the electromagnetic brake
			10	C.OFF	Motor current off
	17		HOME/PRESET ^{*5}	HOME: Starts return-to-home operation PRESET: Presets the current position	
	30		REQ	ABS data request	
	31		FP+	Pulse input operation in the + coordinate direction	
	32		FP-		
	33		P24-FP		
	34		RP+	Pulse input operation in the - coordinate direction	
	35		RP-		
	36		P24-RP		

*1 Connect this signal to 24 VDC if your controller is used in the NPN mode, or connect it to ground if the controller is used in the PNP mode.

*2 Connect this signal even when only output signals are used.

*3 Connect this signal to ground if your controller is used in the NPN mode, or connect it to 24 VDC if the controller is used in the PNP mode.

*4 If the REQ input is ON, these signals switch to the OUTR output, OUTO output, OUT1 output and CK input, respectively. If the REQ input is OFF, they switch the END output, TIM output, T-UP output and ACL input, respectively.

*5 Switch between the HOME and PRESET using the I/O parameter "HOME/PRESET switching"

● Connection Diagram

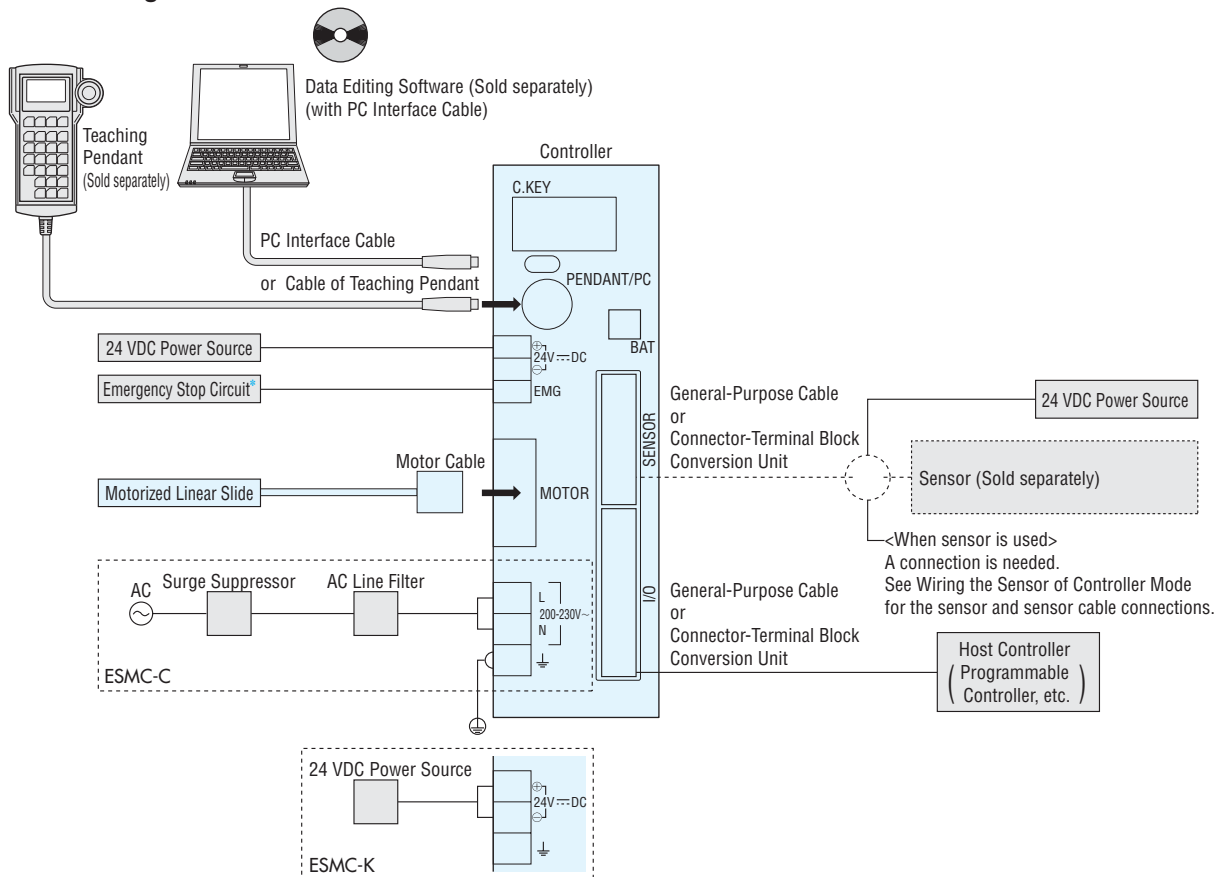

*For the circuit configuration, refer to "Example of connecting power-supply and emergency-stop lines" below.

● Connection Example of Power System and Emergency Stop System

A connection example of controller power system and emergency stop system is given below, which conforms to the EN 954-1 safety standard (Category 1).

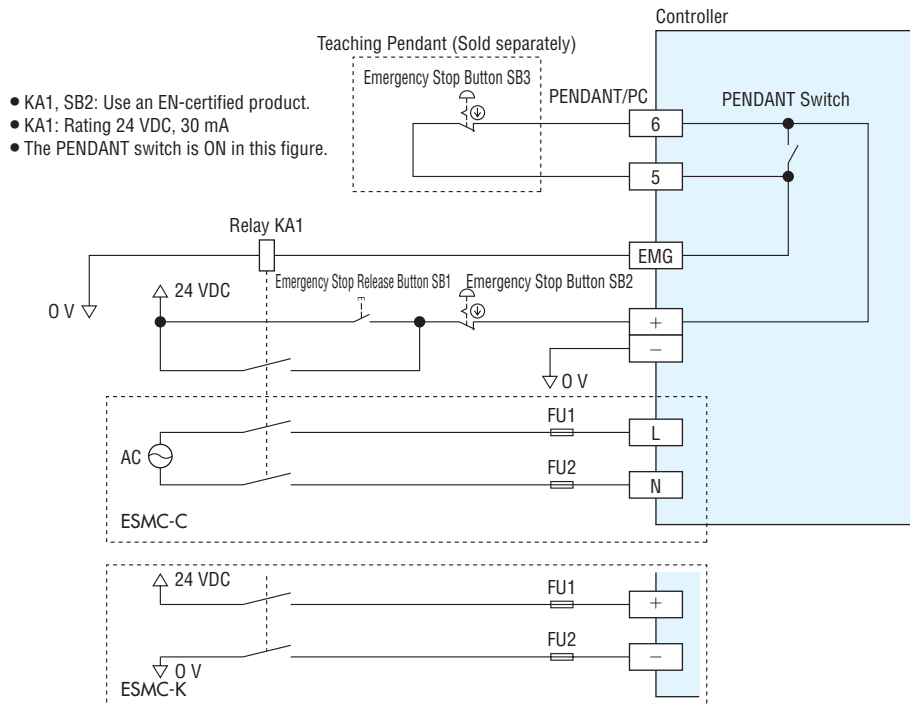

- KA1, SB2: Use an EN-certified product.
- KA1: Rating 24 VDC, 30 mA
- The PENDANT switch is ON in this figure.

◇ Power Source

- Two types of power source, main power and control power, are required. Both power sources must at least have the specified capacity. (See page 32 for Specifications of Controller)
- If the power capacity is insufficient, motor output may drop, which may cause the linear slide to malfunction (due to lack of thrust force).

◇ Notes:

- Wire the control I/O signal lines over as short a distance as possible, using a multiple-core, twisted-pair blanket shield cable [AWG28 (0.08 mm²) or more].
- Be sure to use an optional motor cable and actuator communication cable to wire the linear slide and controller.
- Wire the control I/O signal lines by providing a minimum distance of 30 cm from the power lines (large-current circuits such as the power supply line and motor line). Do not wire the control I/O signal lines with the power lines in the same duct or bundle them together.

◆ Controller Mode
 · Sink Logic (NPN Specification)

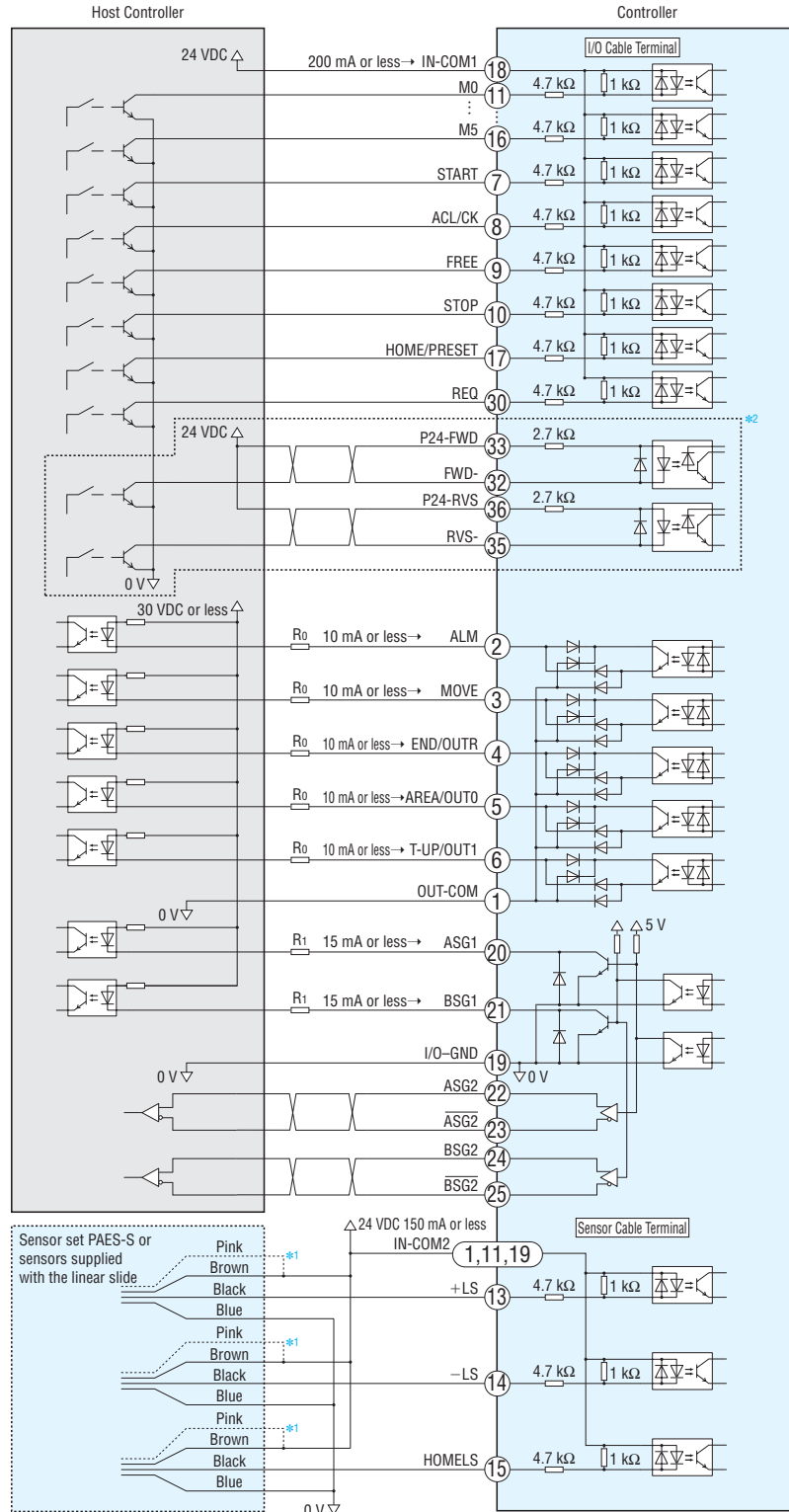

*1 Connect this line if the normal close (NC) logic is used.
 *2 For the wiring of pins 31 to 36, refer to "FWD (FP) and RVS (RP) Signals" on page 40.

◇ Driver Mode

· Source-Logic (PNP) Specification

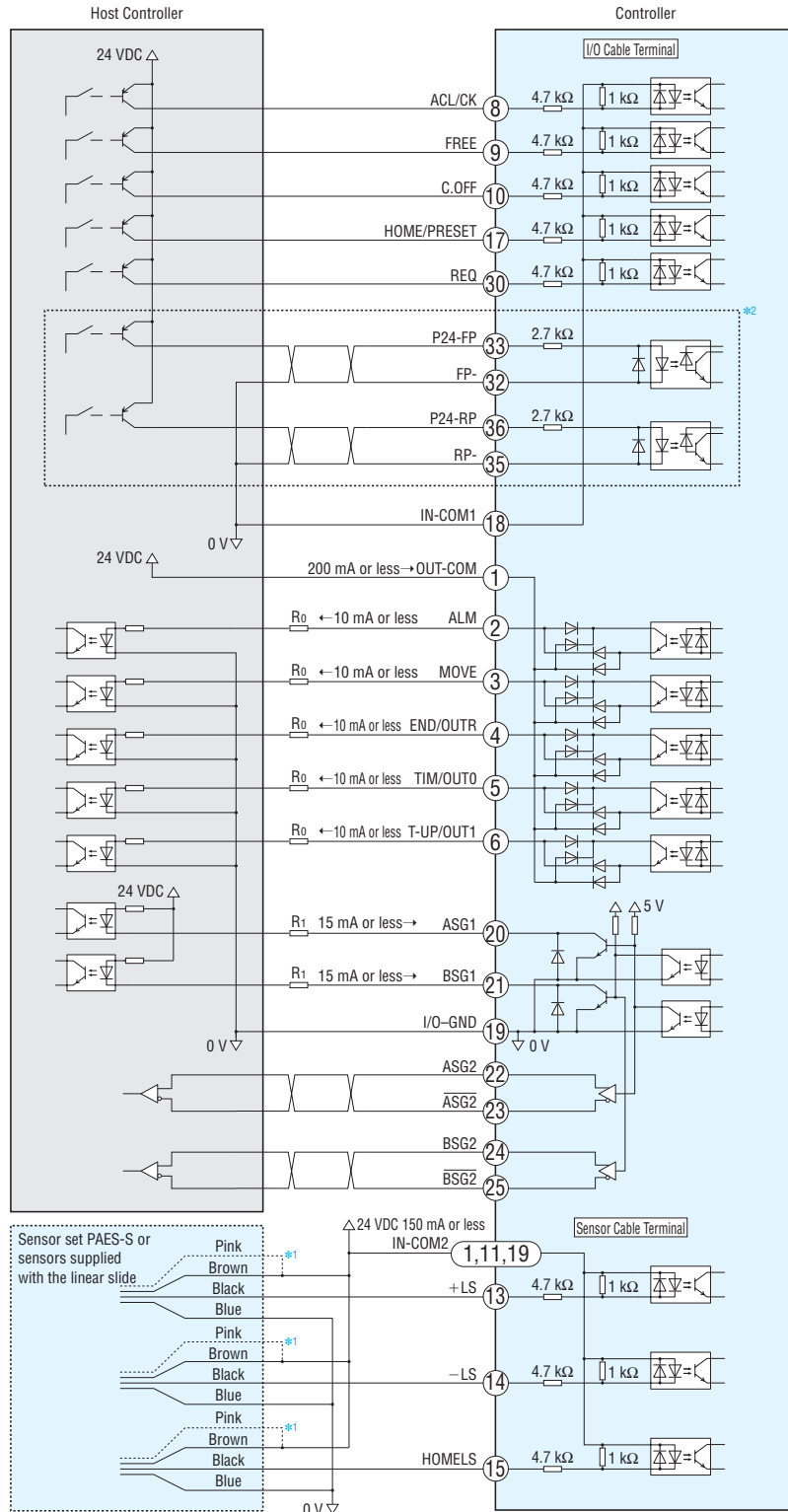

*1 Connect this line if the normal close (NC) logic is used.

*2 For the wiring of pins 31 to 36, refer to "FWD (FP) and RVS (RP) Signals" on page 40.

◇ Driver Mode

· Sink Logic (NPN) Specification

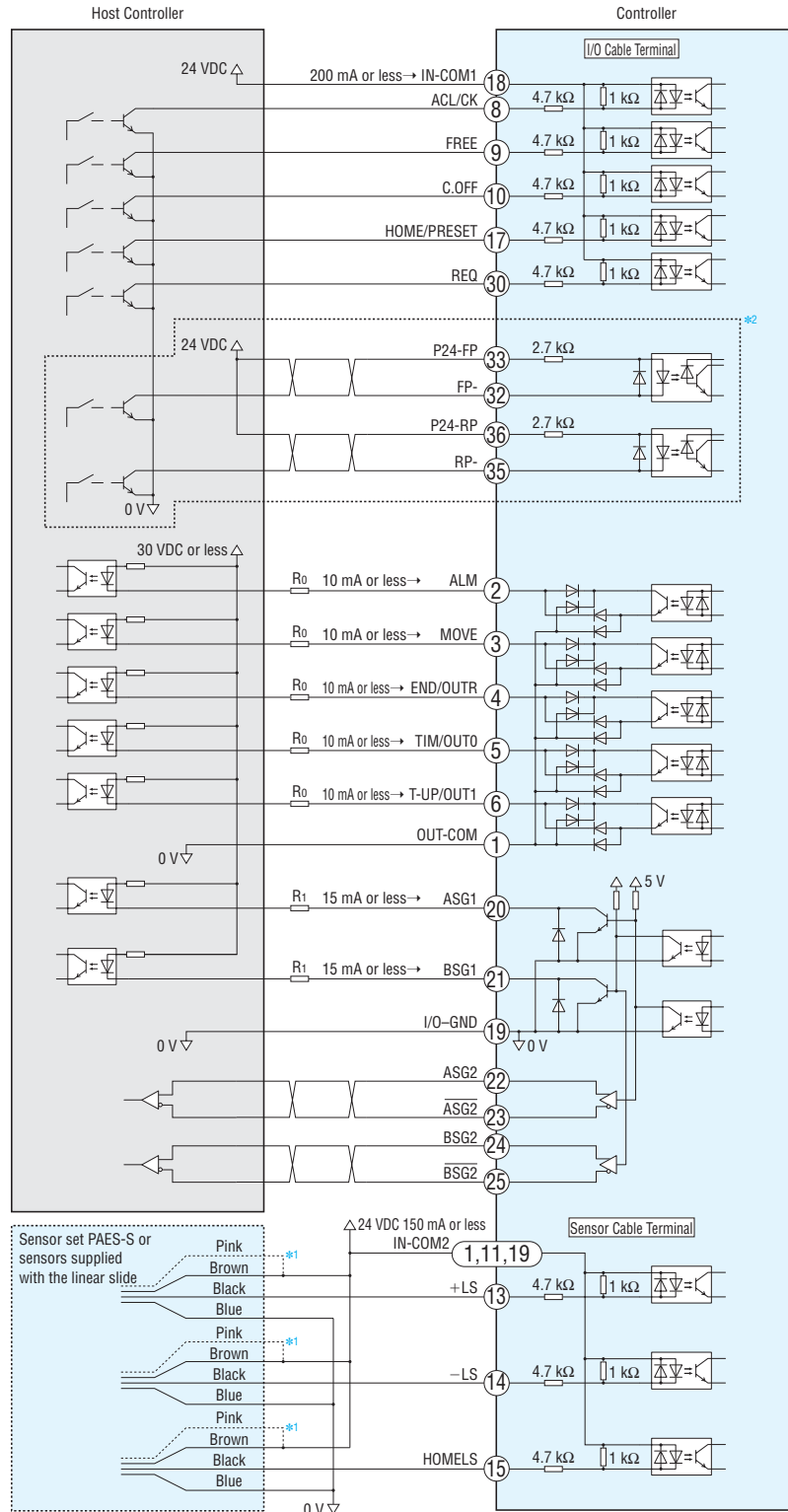

*1 Connect this line if the normally closed (NC) logic is used.
 *2 For the wiring of pins 31 to 36, refer to "FWD (FP) and RVS (RP) Signals" on page 40.

◇ FWD (FP) and RVS (RP) Signals

Connecting to a 5-VDC type controller-Source-logic (PNP) specification

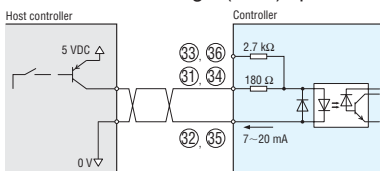

● For connection to a 24-VDC controller, refer to page 37 or 39.

Connecting to a 5-VDC type controller-Sink-logic (NPN) specification

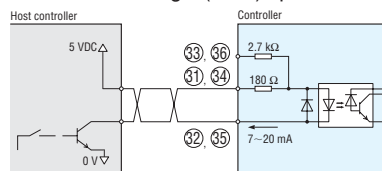

● For connection to a 24-VDC controller, refer to page 38 or 40.

Connecting to a line-driver output circuit

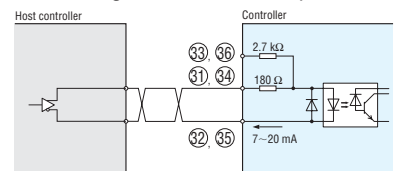

Accessories (Sold separately)

Teaching Pendant

The teaching pendant allows you to set and operate various data on hand, as well as to monitor the set data, current position and I/O status in real time.

Model
EZT1



Dimensions (Unit = mm)

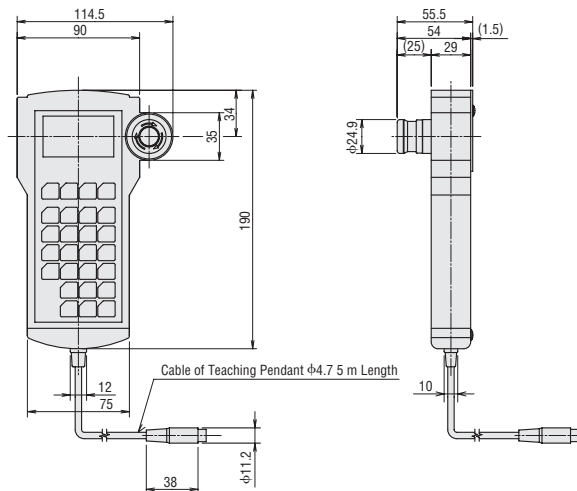

Specifications

Display	LCD with 2-colored back light
Cable Length	5 m
Mass	0.37 kg
Ambient Temperature	0°C~+40°C (nonfreezing)

Data Editing Software (RoHS)

With this software you can set and edit various data on a PC. It comes with a PC interface cable for connecting the controller and PC. The software also provides various monitoring functions.

Model
EZED2

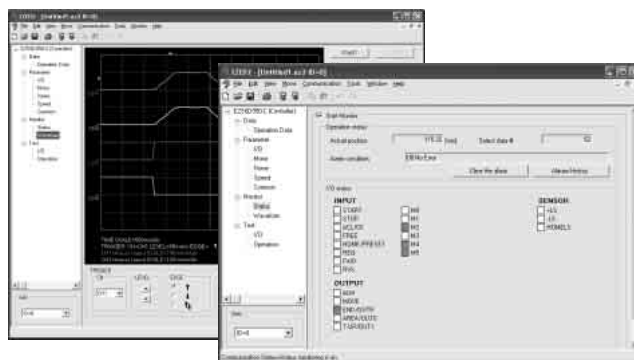

PC Interface Cable

Cable Length	5 m
PC Connector Type	D-sub 9-Pin
Communication Port	One RS-232C Communication Port

Specifications

Operating Environment

Item	Model: EZED2
Operating Software	Microsoft® Windows® 2000 Professional, Service Pack 4 or later (hereinafter referred to as "Windows® 2000") Microsoft® Windows® XP Home Edition, Service Pack 2 or later (hereinafter referred to as "Windows® XP") Microsoft® Windows® XP Professional Edition, Service Pack 2 or later (hereinafter referred to as "Windows® XP") Microsoft® Windows® XP Media Center Edition 2004 Service Pack 2 or later (hereinafter referred to as "Windows® XP") Microsoft® Windows® XP Media Center Edition 2005 Service Pack 2 or later (hereinafter referred to as "Windows® XP") Microsoft® Windows® 98, Service Pack 1 or later* (hereinafter referred to as "Windows® 98") Microsoft® Windows® 98 Second Edition* (hereinafter referred to as "Windows® 98") Microsoft® Windows® Millennium Edition* (hereinafter referred to as "Windows® Me")
Memory	Windows® 2000: 128 MB or more (192 MB or more is recommended.) Windows® XP Home Edition or Professional Edition: 256 MB or more Windows® XP Media Center Edition 2004 or 2005: 320 MB or more Windows® 98: 64 MB or more (128 MB or more is recommended.) Windows® 98 Second Edition: 64 MB or more (128 MB or more is recommended.) Windows® Me: 96 MB or more (160 MB or more is recommended.)
Computer	Pentium® III 500 MHz or more (The OS must be supported.)
Display Resolution	XGA (1024×768) or higher resolution video adapter and monitor
Free Hard Disk Space	Free disk space of 60 MB or more
Serial Port	RS-232C port, 1 channel
Disk Device	CD-ROM drive

*Microsoft® Internet Explorer 5.01 or later is also required.

●Service Pack signifies a service pack provided by Microsoft Corporation.

●Microsoft and Windows are registered trademarks of Microsoft Corporation in the United States and other countries.

●Data editing software operation under English OS environment has been verified.

Teaching Pendant (EZT1)/Data Editing

Software (EZED2) Function Comparison Table

Functions	Item	
	Teaching Pendant (EZT1)	Data Editing Software (EZED2)
Cable Length	5 m	5 m*1
Display	LCD 17 characters × 4 lines	PC screen
Emergency Stop Switch	○	×
Operation Data Setting	○	○
Parameter Setting	○	○
Teaching Function (Direct/Remote)	○	○
Operation Data Monitoring	○	○
I/O Monitoring	○	○
Waveform Monitoring	×	○
Test Operation	○	○
Data Copy	×	○
Printing Function	×	○*2

*1 PC interface cable (supplied) is used.

*2 The printing function is not available on computers running Windows® 98/Me.

Motor Cable RoHS

A set of dedicated cables is used to connect the linear slide with the controller. Use flexible cables in applications where the cables will flex repeatedly. (For both the electromagnetic brake type and non-electromagnetic brake type.)

Note:

- The types of applicable cables are different depending on the power input of the product used.



Product Line

◇ 24 VDC, Single-Phase 200-230 VAC

[Standard Cable (Without Electromagnetic Brake/
With Electromagnetic Brake)]

Length (L)	Model
1 m	CC010ES-2
2 m	CC020ES-2
3 m	CC030ES-2
5 m	CC050ES-2
7 m	CC070ES-2
10 m	CC100ES-2
15 m	CC150ES-2
20 m	CC200ES-2

*Keep the cable length to 10 m or below for 24-VDC linear slides.

[Flexible Cable (Without Electromagnetic Brake/
With Electromagnetic Brake)]

Length (L)	Model
1 m	CC010ESR-2
2 m	CC020ESR-2
3 m	CC030ESR-2
5 m	CC050ESR-2
7 m	CC070ESR-2
10 m	CC100ESR-2
15 m	CC150ESR-2
20 m	CC200ESR-2

*Keep the cable length to 10 m or below for 24-VDC linear slides.

Dimensions (Unit = mm)

CC□ES-2/CC□ESR-2

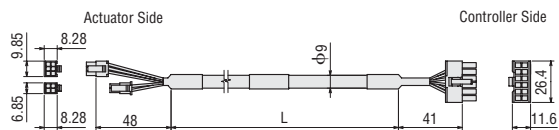

General-Purpose Cables RoHS

These cables are used for connection between the **EZ limo** controller and the host controller, or **EZ limo** controller and the sensors.

A half-pitch connector allowing one-touch connection to the controller is attached at one end of the flat cable.



Product Line

Model	Length (L)	Applications
CC36D1-1	1 m	For connection between the EZ limo controller and the host controller.
CC36D2-1	2 m	
CC20D1-1	1 m	For connection between the EZ limo controller and the sensors.
CC20D2-1	2 m	

Dimensions (Unit = mm)

CC36D1-1, CC36D2-1

Conductor: AWG28 (0.08mm²)

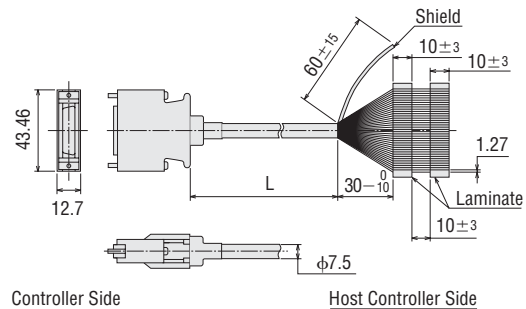

CC20D1-1, CC20D2-1

Conductor: AWG28 (0.08mm²)

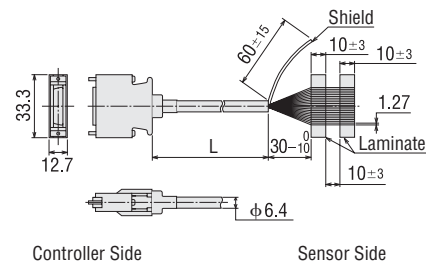

Connector-Terminal Block Conversion Unit (RoHS)

A conversion unit that connects a driver to a host controller or sensors using a terminal block.

- With a signal name plate for easy, one-glance identification of driver signal names.
- DIN-rail mountable
- Cable length: 1 m

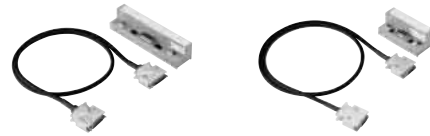

Product Line

Model	Length (L)	Applications
CC36T1	1 m	For connection between the EZ limo controller and the host controller.
CC20T1	1 m	For connection between the EZ limo controller and the sensors.

Dimensions (Unit = mm)

CC36T1

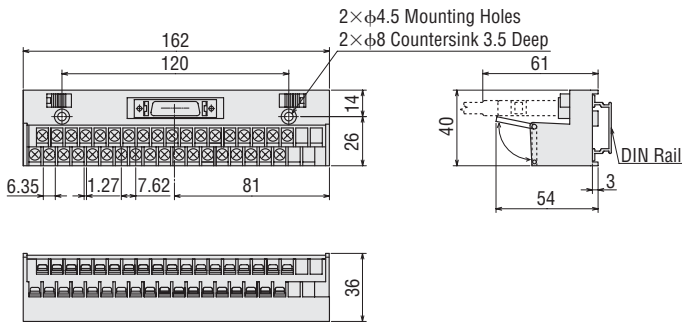

Terminal Block Pin No.

19	20	21	22	23	24	25	26	27	28	29	30	31	32	33	34	35	36
1	2	3	4	5	6	7	8	9	10	11	12	13	14	15	16	17	18

CC20T1

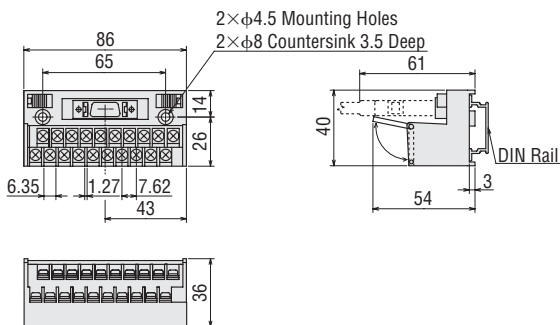

Terminal Block Pin No.

11	12	13	14	15	16	17	18	19	20
1	2	3	4	5	6	7	8	9	10

Recommended Crimp Terminals

- Terminal screw size: M3
- Tightening torque: 1.2 N·m
- Applicable minimum lead wire: AWG22 (0.3 mm²)

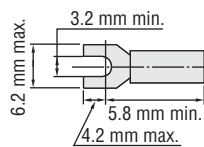

■ Sensor Set (RoHS)

These sensors can be used in the controller mode or driver mode. The sensor set consists of three sets of a sensor, a sensor mounting bracket and a cable with connector, and one shield plate. The screws needed for installation are also provided.

Model
PAES-S

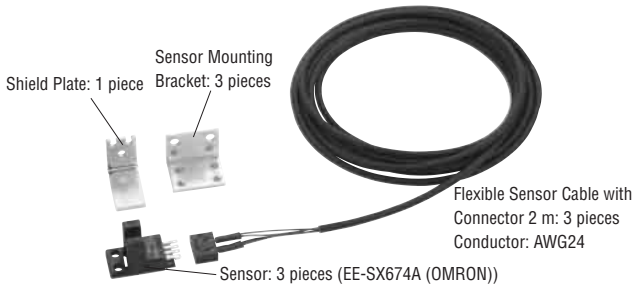

● Specifications

Item	Model: EE-SX674A (OMRON)
Power Supply	5 to 24 VDC $\pm 10\%$, ripple (P-P) 10% or less
Current Consumption	35 mA or less
Control Output	NPN open-collector output, 5 to 24 VDC, 100 mA or less Residual voltage 0.8 V or less (at load current of 100 mA)
Indicator Lamp	Detection display (red)
Sensor Logic	Normal open/Normal close (switchable, depending on connection)

● Connection Example (Controller mode)

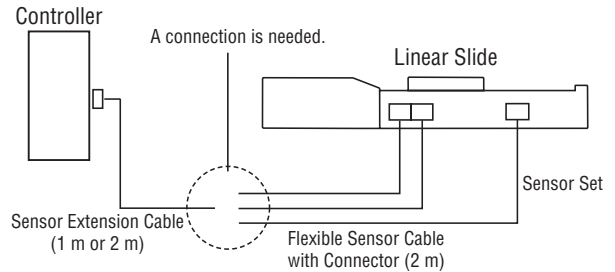

● Dimensions of Recommended Sensor Installation Positions (Unit = mm)

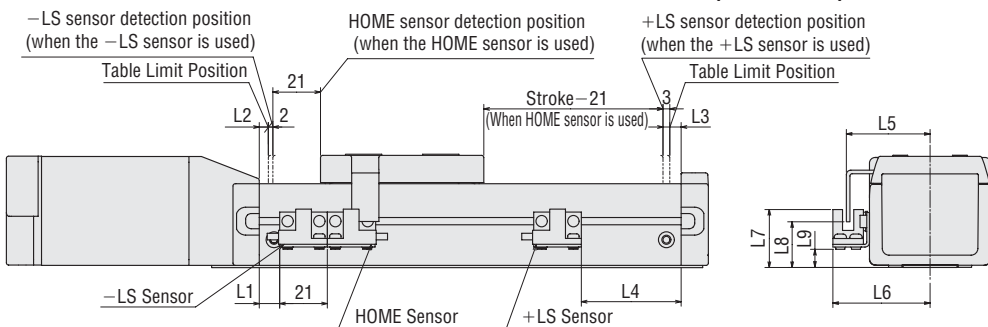

Linear Slide Size	L1	L2	L3	L4	L5	L6	L7	L8	L9
EZS3	9	4	5	44	37.3	43.3	25.8	20.4	8.1
EZS4	9	4	5	44	47.3	53.3	25.8	20.4	8.1
EZS6	13.5	8	13	87.5	47.3	53.3	42.3	36.9	24.6

Note:

- If the stroke is 60 mm or below, all three sensors cannot be installed.

■ Mounting Bracket (RoHS)

This mounting bracket allows easy installation of a pair of linear slides.
Various types of brackets are available to support combinations of X-Y and X-Z axes.

● For further information on the mounting bracket, please contact the nearest Oriental Motor office.

X-Y Configuration

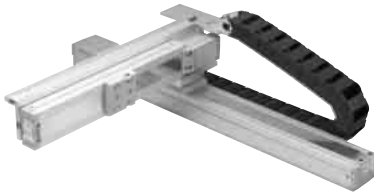

X-Z Configuration



Cable Holder

This cable holder protects and guides cables in dual or three-axis configurations. It can be easily installed on a **EZS II** Series mounting bracket using the supplied brackets.

Applicable Products		Applicable Cable Holder	
Applicable Products	Stroke [mm]	Length (L) [mm]	Model
EZS II Series	50~70	396	PACH65-11
	80~120	468	PACH65-13
	130~170	504	PACH65-14
	180~220	540	PACH65-15
	230~270	612	PACH65-17
	280~320	648	PACH65-18
	330~370	720	PACH65-20
	380~420	756	PACH65-21
	430~470	792	PACH65-22
	480~520	864	PACH65-24
	530~570	900	PACH65-25
	580~620	972	PACH65-27
	630~670	1008	PACH65-28
	680~720	1044	PACH65-29
730~770	1116	PACH65-31	
780~820	1152	PACH65-32	
830~850	1224	PACH65-34	



Dimensions (Unit = mm)

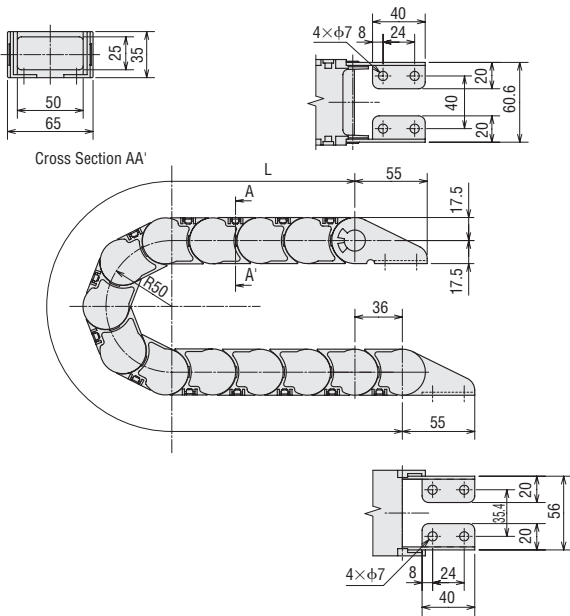

Model	L (mm)
PACH65-11	396
PACH65-13	468
PACH65-14	504
PACH65-15	540
PACH65-17	612
PACH65-18	648
PACH65-20	720
PACH65-21	756
PACH65-22	792
PACH65-24	864
PACH65-25	900
PACH65-27	972
PACH65-28	1008
PACH65-29	1044
PACH65-31	1116
PACH65-32	1152
PACH65-34	1224

This product is manufactured at a plant certified with the international standards **ISO 9001** (for quality assurance) and **ISO 14001** (for systems of environmental management).

Specifications are subject to change without notice.
This catalogue was published in November, 2006.

Orientalmotor

ORIENTAL MOTOR (EUROPA) GmbH

www.orientalmotor.de

European Headquarters and Düsseldorf Office

Schießstraße 74
40549 Düsseldorf, Germany
Tel: 0211-5206700 Fax: 0211-52067099

Munich Office

Liebigstraße 14
85757 Karlsfeld, Germany
Tel: 08131-59880 Fax: 08131-598888

Hamburg Office

Meckelfelder Weg 2
21079 Hamburg, Germany
Tel: 040-76910443 Fax: 040-76910445

Stuttgart Office

Tel: 07335-924853 Fax: 07335-924854

ORIENTAL MOTOR (UK) LTD.

www.oriental-motor.co.uk

Unit 5, Faraday Office Park,
Rankine Road, Basingstoke,
Hampshire RG24 8AH U.K.
Tel: 01256-347090 Fax: 01256-347099

ORIENTAL MOTOR (FRANCE) SARL

www.orientalmotor.fr

France Headquarters

32, Avenue de l'île Saint Martin
92737 Nanterre Cedex, France
Tel: 01 47 86 97 50 Fax: 01 47 82 45 16

Lyon Office

10, Allée des Sorbiers
69673 Bron Cedex, France
Tel: 04 78 41 15 02 Fax: 04 78 41 15 90

ORIENTAL MOTOR ITALIA s.r.l.

www.orientalmotor.it

Italy Headquarters

Via A. De Gasperi, 85
20017 Mazzo di Rho (MI), Italy
Tel: 02-93906346 Fax: 02-93906348

Bologna Office

Via mori, 6
40054 Prunaro di Budrio (BO), Italy
Tel: 051-6931249 Fax: 051-6929266

ORIENTAL MOTOR CO., LTD.

www.orientalmotor.co.jp

Headquarters

16-17, Ueno 6-chome
Taito-ku, Tokyo 110-8536, Japan
Tel: (03)3835-0684 Fax: (03)3835-1890

For more information please contact:



This printed material uses recycled paper and soy inks. This combination is environmentally friendly.

Printed in Japan 06Y 4K 29750K