

# Solutions for Food & Beverage Processing

Food & Beverage



MARKETS &  
APPLICATIONS





# Food & Beverage



## Grain Handling & Milling

Page 4 to 9



## Food Baking

Page 10 to 15



## Fruit & Beverage Processing

Page 16 to 21

## The widest range of solutions for Food & Beverage processing and machinery

Within the Food & Beverage industry, Bonfiglioli offers a diverse range of solutions for all types of applications. We have decades of experience in developing customized solutions for the most challenging applications around the world and incomparable expertise in typical Food & Beverage processing applications.

Some of the biggest product lines and most advanced applications in the world are powered by at least one Bonfiglioli solution, final drive, gearbox, gearmotor or inverter.

Bonfiglioli also offers specific products for hygienic, explosion-proof and enhanced protection, developed to deliver the reliability and durability typically demanded by the Food & Beverage sector.

### Bonfiglioli also provides solutions for:



FISH & MEAT PROCESSING



POULTRY PROCESSING



DAIRY PROCESSING



PACKAGING

Bonfiglioli also provides solutions for:



PACKAGING PROCESSES



SUGAR CANE MILL PLANTS

[www.bonfiglioli.com](http://www.bonfiglioli.com)

### Products for all types of food processing equipment:

- Drying and cooking machines
- Extrusion machines (Food and Pet Food)
- Freezing and chilling lines (spiral freezers, tunnel freezers, carton freezers, ...)
- Grinding and sorting machines
- Grain logistic systems
- Grinding and flaking machines
- Homogenizing machines
- Milling machines
- Mixing / Stirring machines
- Presses
- Rendering systems
- Conveyors

# Grain Handling & Milling

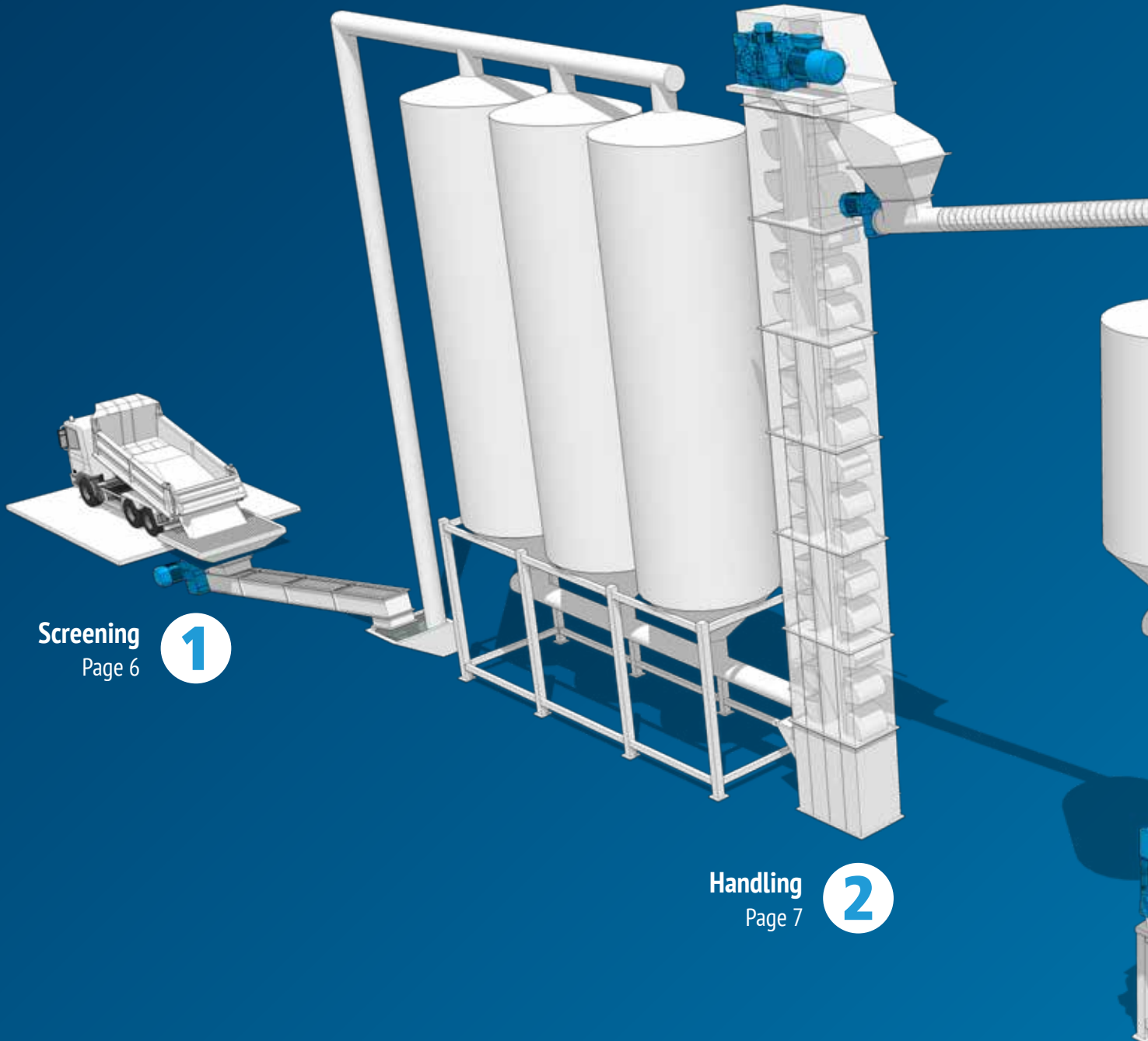

Screening  
Page 6

1

Handling  
Page 7

2

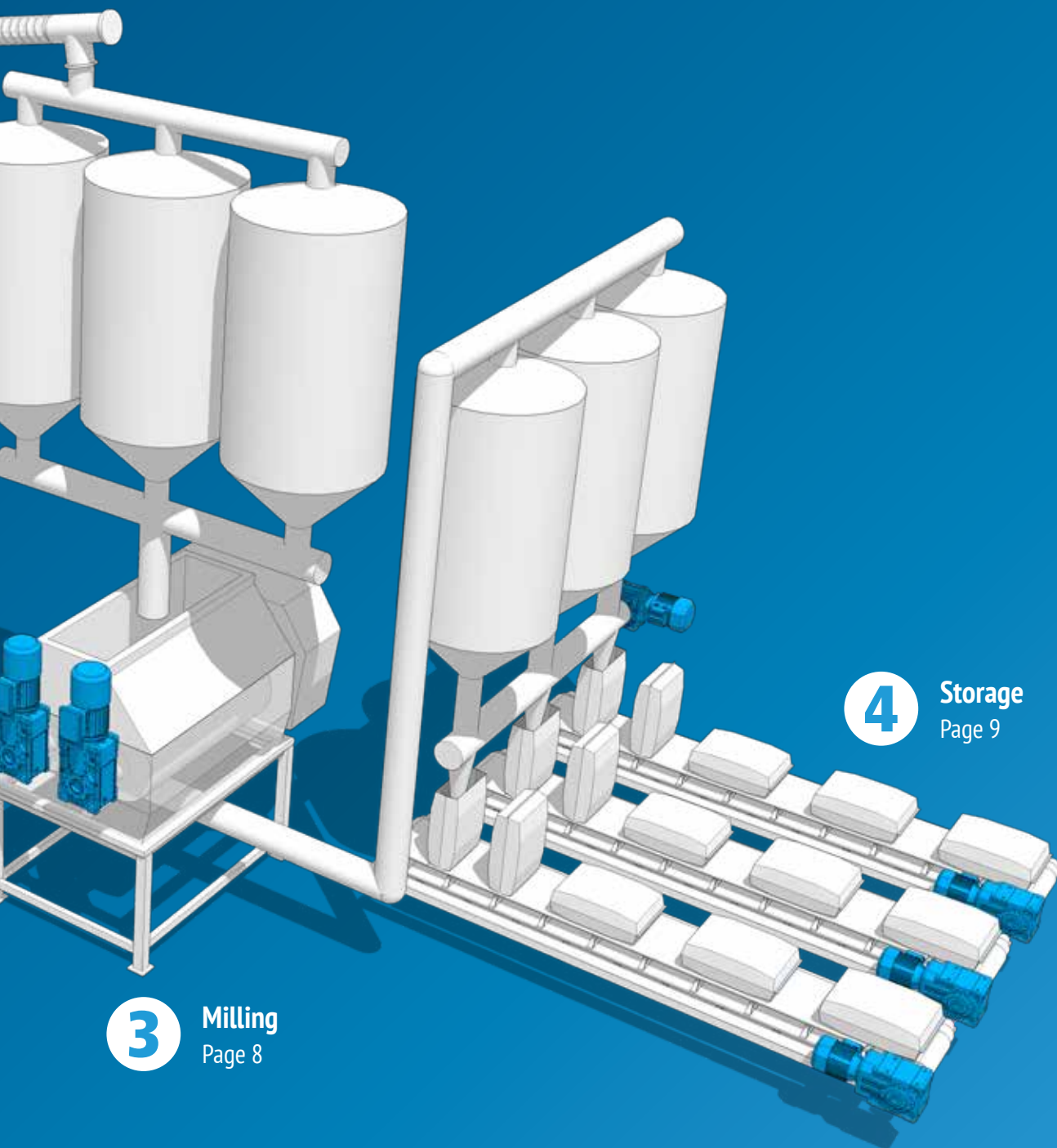

**3** Milling  
Page 8

**4** Storage  
Page 9

# Grain Handling & Milling

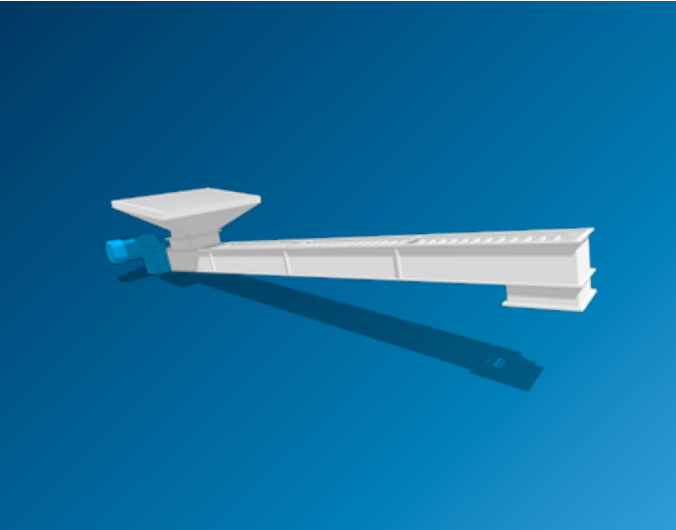

## Screening Drag conveyor

1

Because this high-volume application is stressed continuously, we offer versatile, highly resistant, energy-efficient products that enhance production. Moreover, our gearboxes are ATEX certified, guaranteeing the highest level of protection for our customers.

### F Series |

#### Shaft mounted gearbox and geared motor

##### Benefits

- Easy installation
- Quiet operation
- High torque capabilities

##### Features

- ATEX-compliant gearboxes (according to Directive 2014/34/EU)
- Keyed hollow shaft with two bore options per size, or hollow shaft with shrink (metric and imperial dims)
- Backstop device
- Surface protection class C3, C4 and C5 (according to standard UNI EN ISO 12944-2)
- High and premium efficiency motors (IE2, IE3)
- Anti-condensation heaters and tropicalized windings
- Energy efficiency approval by DOE (USA Department of Energy) and NRCAN (Natural Resources Canada)





## Handling

### Bucket elevators

2

Bonfiglioli's extensive expertise in this application ensures our customers a range of solutions tailored to their needs. Gearmotors with integrated base plates to simplify installation, auxiliary drives to ease machine maintenance, backstop devices to increase application safety, and elastic couplings to smooth out start/stop procedures are only a few of the benefits that Bonfiglioli products provide to customers.

## HDO Series

Heavy duty gearbox and geared motor with

## A Series

Helical bevel geared motors auxiliary drive

### Benefits

- Integrated solution for auxiliary and main drives
- High power capacity
- One-stop-shop for a complete drive solution
- Extended lifetime & reliability

### Features

- Self engaging auxiliary drive for machine maintenance operations
- Backstop and overrun clutch device
- ATEX compliant gearbox according to Directive 2014/34/EU
- Torque up to 210 000 Nm
- Oil level and temperature sensors, torque arm and coupling integrated self-cooling system and coupling
- Integrated forced oil lubrication option
- Surface protection class C3, C4 and C5 (according to standard UNI EN ISO 12944-2)
- Brake motors
- AC or DC brake type
- Micro-switch (control of brake operation)
- Anti-condensation heaters and tropicalized windings
- Forced ventilation with independent cooling



## Active Cube Series

### Premium inverter

### Benefits

- IP54 option
- Smooth start
- Torque control
- Motor temperature monitoring

### Features

- Series optionally extendable for field bus communication and encoder evaluation
- Plug-in power terminals (up to 3kW)
- Plug-in and programmable control terminals
- DC link connection
- Integrated brake chopper
- Positioning function via field bus (Motion Control compatible to CiA DS402)
- Integrated VPLC
- Master/slave function with electronic gear
- Power failure control
- Integrated safe torque off STO (SIL 3 / PL e) function
- Output frequency 0...599 Hz, higher frequencies on request
- Diagnosis and setup via optional keypad or PC software



# Grain Handling & Milling

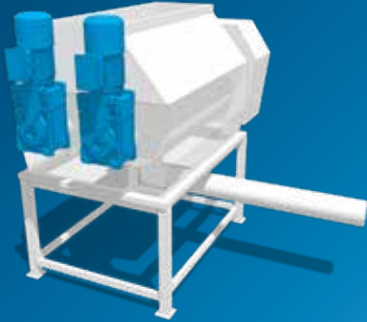

## Milling

### Crushers, flaking & milling machines

3

Bonfiglioli solutions for flaking and milling ensure smooth operation to optimize the grinding of wheat into flour. For speed control, Bonfiglioli provides a complete drive solution from the gearmotor to the inverter. Bonfiglioli drives can safely operate in dusty milling environments, and their easy maintenance reduces downtime.

## HDO Series

### Heavy duty gearbox and geared motor (Bevel-Helical)

#### Benefits

- One-stop-shop for complete drive solutions
- Highly transmissible power
- Extensive customization
- Quiet operations
- External cooling-system free

#### Features

- Strengthened E-motor input flange with integrated with self cooling system and coupling
- Torque range up to 210 000 Nm
- ATEX-compliant gearbox according to Directive 2014/34/EU
- Integrated forced lubrication
- Taconite seals
- Protective hollow shaft cover
- High rigidity and stiffness gear case
- Strengthened E-motor flange with integrated self-cooling and coupling
- Oil level and temperature sensors
- Surface protection class C3, C4 and C5 (according to standard UNI EN ISO 12944-2)
- High and premium efficiency motors (IE2, IE3)
- Thermal protection (bi-Metallic, PTC or KTY)
- Protective canopy
- Rotor balancing class A (standard) or B (available on request)



## Agile Series

### Smart inverter

#### Benefits

- Smooth start
- Feed roll control
- Low energy consumption

#### Features

- Series optionally extendable for field bus communication
- Sensorless control of synchronous and asynchronous motors
- Modbus and Systembus onboard
- DC link connection
- Integrated brake chopper
- Power failure control
- Programmable PI Controller
- Integrated VPLC
- Master/slave function with electronic gear
- Integrated safe torque off STO (SIL 2 / PL d) function
- Energy Saving function
- Intelligent current limits
- Output frequency 0...599 Hz, higher frequencies on request
- Diagnosis and setup via integrated keypad and integrated Service interface for PC connection





## Storage

### Bagging machines & conveyors

4

Our start-to-finish conveying solutions ensure precise, reliable processes for both bagging machines and conveyors. By meeting the dynamics and control requirements of bagging machines and providing space optimization for conveyors, Bonfiglioli gearmotors can fulfill almost any customer need.

## A Series | Bevel-helical geared motors

### Benefits

- Compact layout
- Flexible mounting
- Modular design

### Features

- ATEX-compliant gearbox (according to Directive 2014/34/EU)
- Keyed hollow shaft (metric and imperial dims)
- Taconite seals option for larger sizes
- Surface protection class C3, C4 and C5 (according to standard UNI EN ISO 12944-2)
- High and premium efficiency motors (IE2, IE3)
- Protection rating up to IP56
- Wide range of feedback devices (incremental and absolute encoders)
- Wide range of connectors



## Active Series Standard AC drive

### Benefits

- Speed control
- Smooth start

### Features

- Motor temperature monitoring
- Main software features:
  - Auto start-up and commissioning
  - Auto start after power failure



# Food Baking

**1** Raw material handling  
Page 12

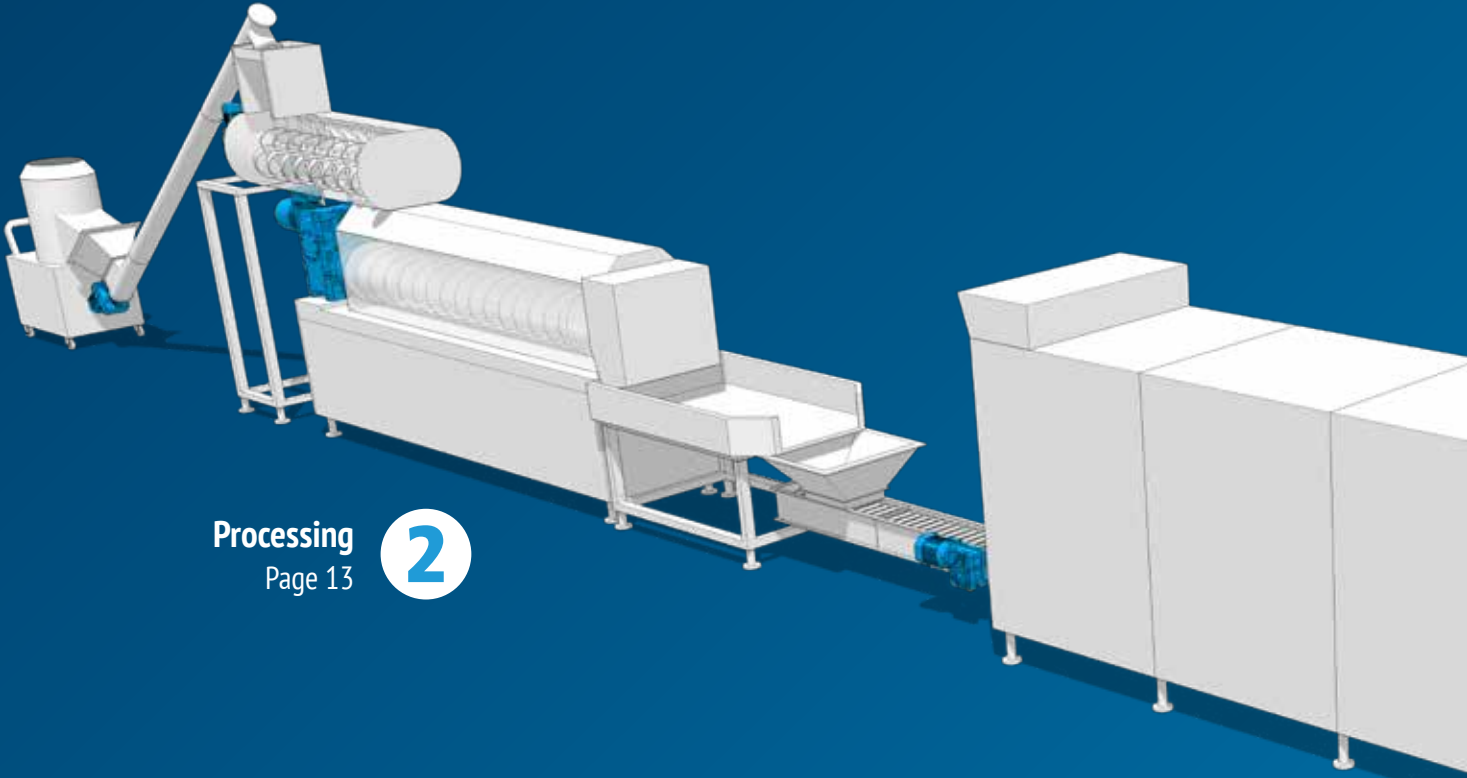

Processing **2**  
Page 13

Drying & cooking line **3**  
Page 14



## 4 Chilling, freezing line

Page 15

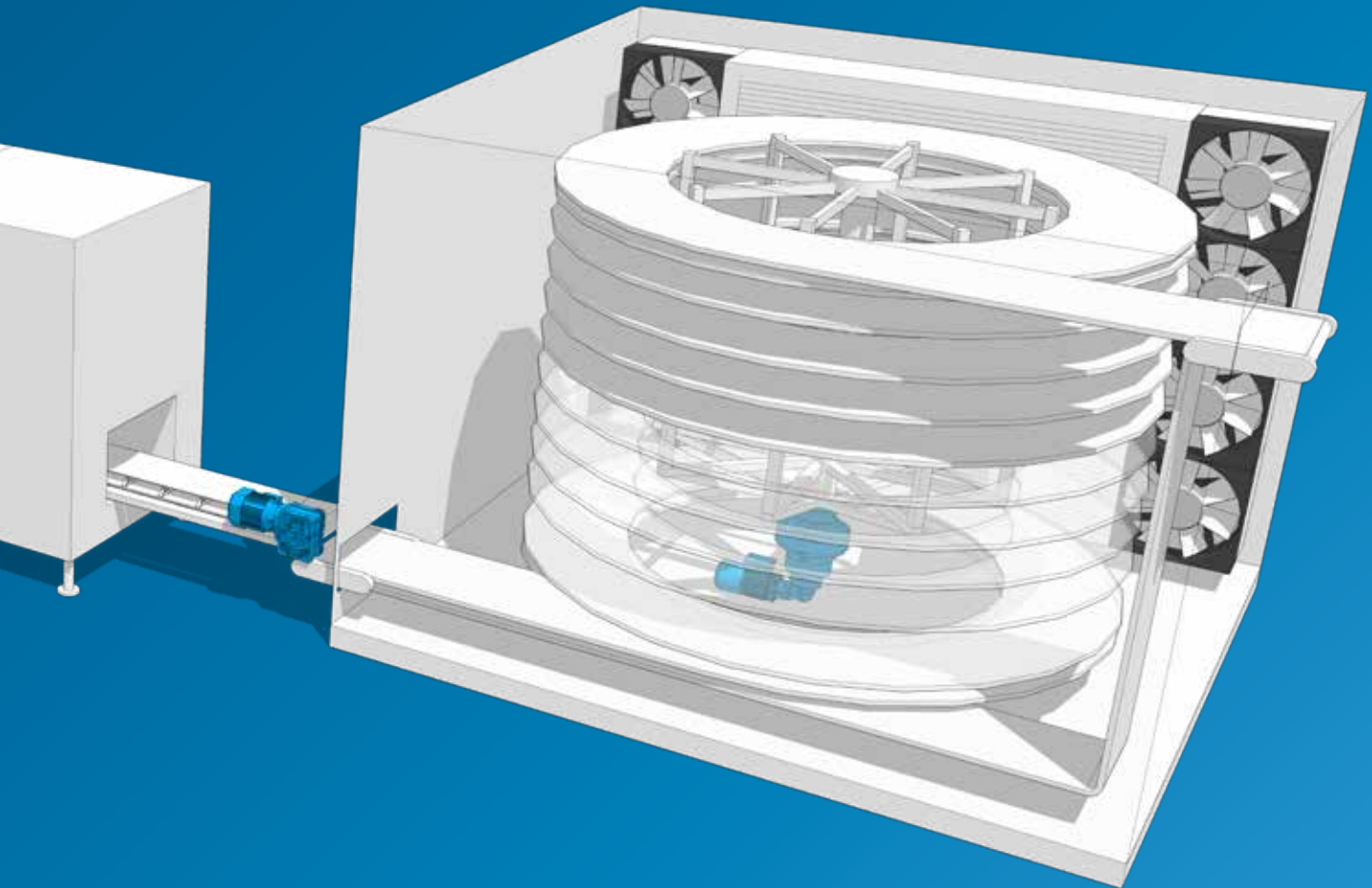

PACKAGING PROCESS SOLUTIONS >

Visit [www.bonfiglioli.com](http://www.bonfiglioli.com) for more information.

# Food Baking

## Raw material handling

### Feed system, conveyor, mixer

1

Raw material handling is the first phase of the baking process. The machines must ensure continuous operation to prevent interruption of the subsequent baking process. Bonfiglioli's raw material handling solutions meet this requirement by combining robustness, flexible assembly and cost effectiveness.

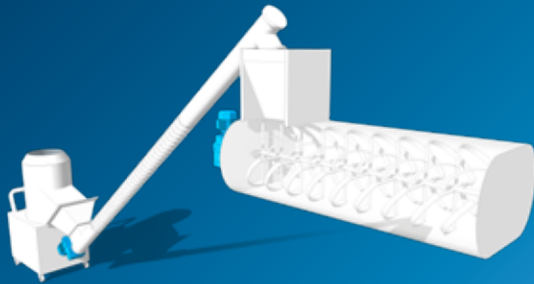

## F Series

### Shaft mounted gearbox and geared motor

#### Benefits

- Easy installation
- Quiet operation
- High torque capabilities

#### Features

- Keyed hollow shaft with two bore options per size, or hollow shaft with shrink disc fitting (metric and imperial dims)
- Backstop device
- Surface protection class C3, C4 and C5 (according to standard UNI EN ISO 12944-2)
- High and premium efficiency motors (IE2, IE3)
- Protection rating up to IP56
- Thermal protection (bi-metallic, PTC or KTY)
- Anti-condensation heaters and tropicalized windings



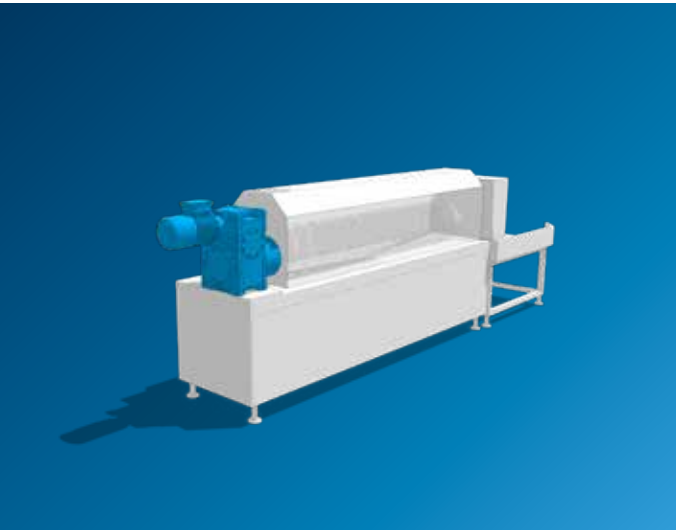

## Processing

### Extruder, shaping machines

2

Mixing and extruding are the two fundamental stages of this particular sub-process. Bonfiglioli solutions for mixers are designed to ensure the optimal homogenization, to best meet the needs of our customers. Furthermore, Bonfiglioli's experience in extruders and molding machines ensures efficiency and reliability, helping yield uniform, quality products at all stages of the process.

## HDPE Series

### Heavy duty gearbox and geared motor

#### Benefits

- Reliable and specific design solution for single-screw extrusion machines
- Easy machine integration thanks to universal mounting gearbox case
- Customized extruder screw interface dimensions

#### Features

- Specific heavy duty thrust bearing sourced exclusively from primary brands
- Robust nodular cast iron gear case suitable for high load capability
- Wide range of cooling system options (external & internal)
- Lubrication shared between gearbox casing and screw box
- High and premium efficiency motors (IE2, IE3)
- Protection rating up to IP56
- Thermal protection (bi-metallic, PTC or KTY)
- Anti-condensation heaters and tropicalized windings



## Active Cube Series

### Premium inverter

#### Benefits

- Soft start
- Positioning mode

#### Features

- Series optionally extendable for field bus communication and encoder evaluation
- Plug-in power terminals (up to 3kW)
- Plug-in and programmable control terminals
- DC link connection
- Integrated brake chopper
- Positioning function via field bus (Motion Control compatible to CiA DS402)
- Integrated VPLC
- Master/slave function with electronic gear
- Power failure control
- Integrated safe torque off STO (SIL 3 / PL e) function
- Output frequency 0...599 Hz, higher frequencies on request
- Diagnosis and setup via optional keypad or PC software



# Food Baking

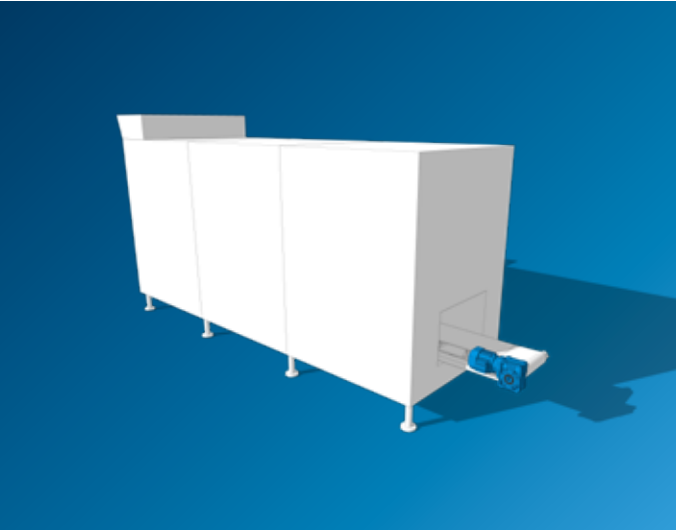

## Drying & cooking line

### Oven, dryer, fryer

3

Bonfiglioli solutions support customers in taking their products from start to finish. Cooking and drying phases require high-quality, heat-resistant solutions specifically designed for the food & beverage industry.

Our broad portfolio enables us to supply specific products for drying and cooking lines. Advanced protection gearmotors will satisfy customers' main requirements.

## W/EP Series

### Worm gearbox and geared motor with enhanced protection

#### Benefits

- Cost-effective
- Uncompromising quality
- Specially designed for food & beverage industries

#### Features

- Epoxy coating (NSF & FDA approved for incidental food contact)
- AISI 316 stainless steel output shaft and stainless steel fasteners
- H1 food grade lubricant
- High and premium efficiency motors (IE2, IE3)
- Protection rating up to IP56
- Thermal protection (bi-metallic, PTC or KTY)
- Anti-condensation heaters and tropicalized windings
- Insulation class F (standard) or H (available on request)
- Surface protection class C5 (according to standard UNI EN ISO 12944-2)





## Chilling, freezing line Spiral freezer

4

Compact and efficient, our solutions allow food manufacturers to freeze their products quickly, with no interruption to the manufacturing process. Bonfiglioli products allow spiral freezers to operate continuously and maximize processing uptime through high manufacturing standards. Most importantly, our gearmotors can safely operate in the extremely low temperatures necessary in the freezing process, and can durably withstand the demanding cleaning procedures.

### 300M Series

#### Planetary gearbox and geared motor

##### Benefits

- High shock load resistance
- Compact design
- One-stop-shop for complete drive solutions
- Reliable and customized solution for extreme low temperature working condition
- Wash down capability

##### Features

- 5-stage planetary bevel geared motors
- Special lubricant and oil seals for low temperature
- Water defender system for oil seals and bearings
- Shot blasting and hot zinc spraying surface treatment
- High and premium efficiency motors (IE2, IE3)
- Protection rating up to IP56
- Thermal protection (bi-metallic, PTC or KTY)
- Anti-condensation heaters
- Total quality inspection certificate



### Active Cube and/or Agile Series Smart inverter

##### Benefits

- Better control of air cooling system
- Energy efficiency

##### Features

- Wide power range from 0.25 to 400 kW
- Coated PCBs
- Integrated PLC function with graphic development environment
- Torque limitation



# Fruit & Beverage Processing

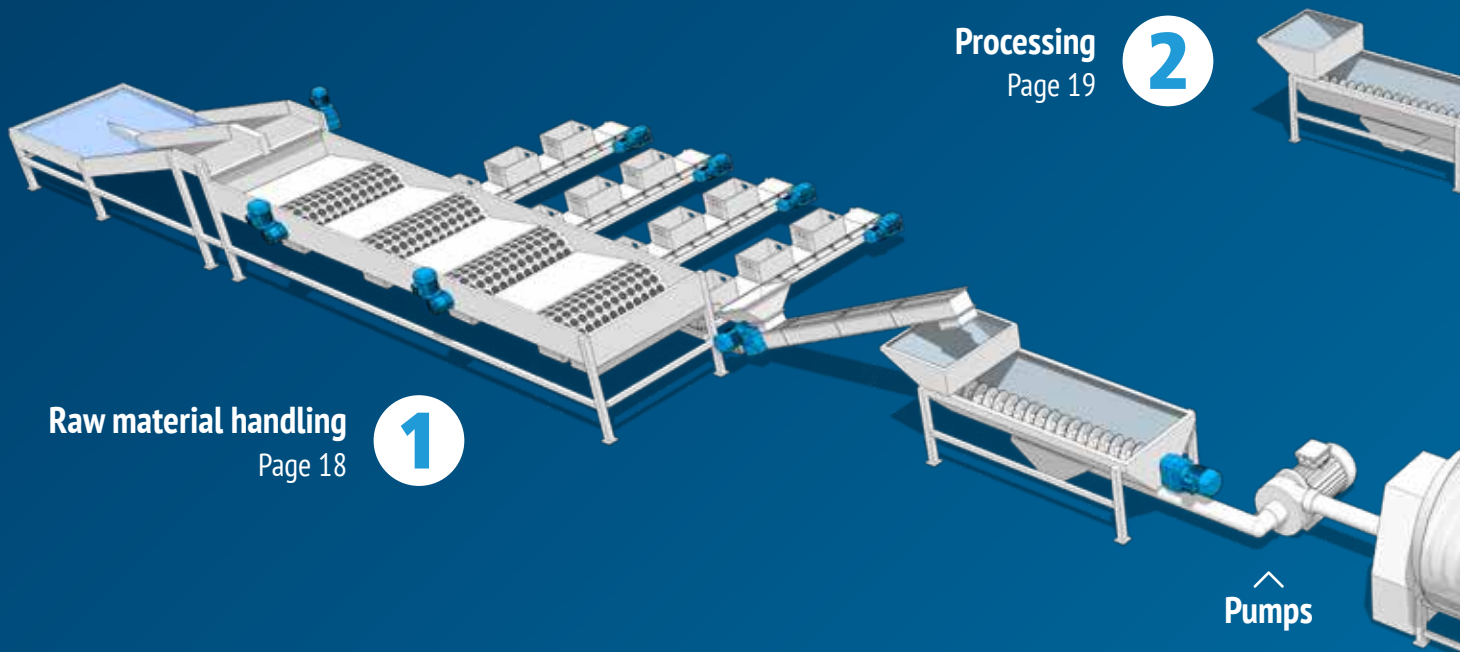

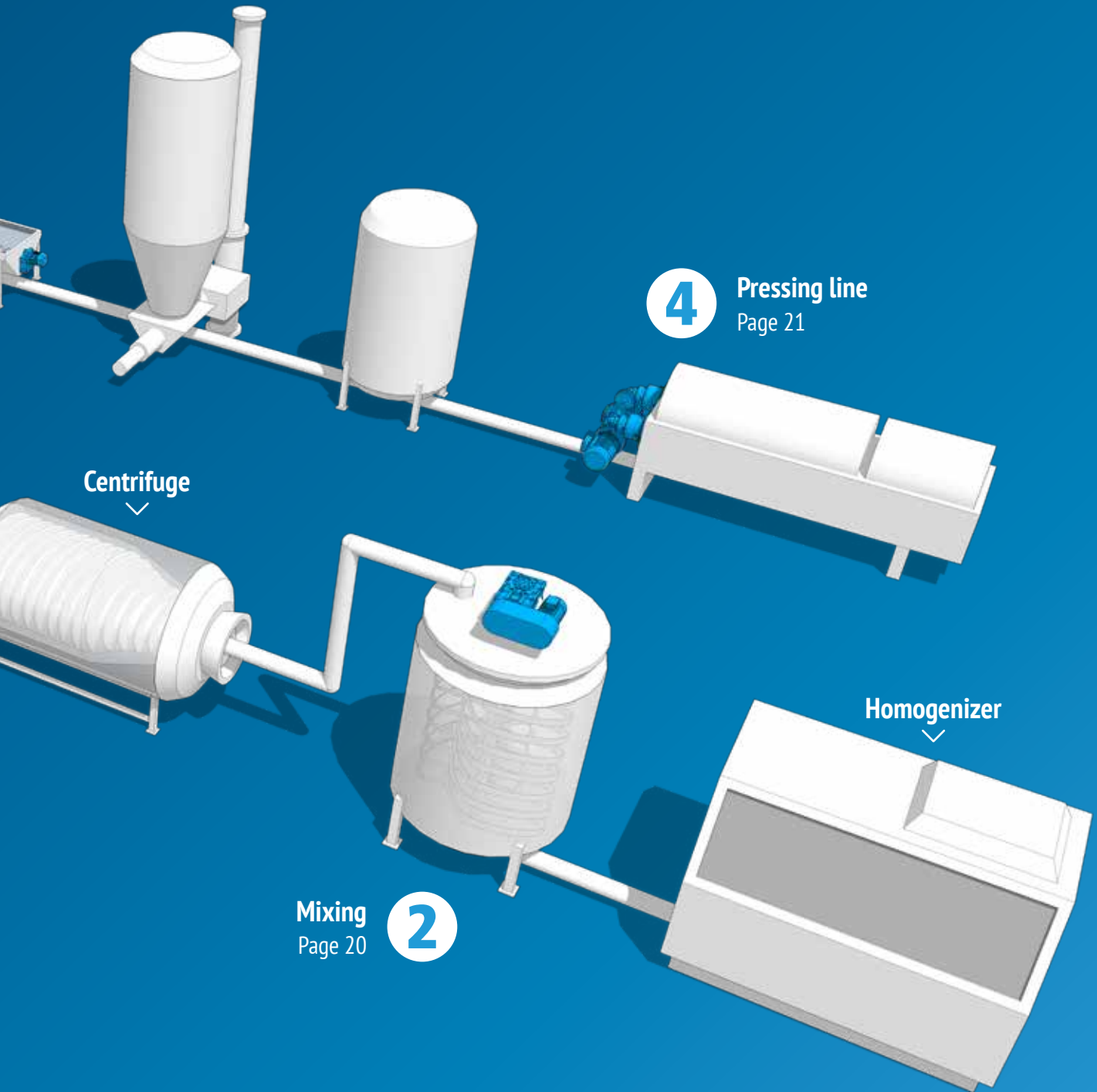

# Fruit & Beverage Processing

## Raw material handling

1

Feeding, washing and sorting systems, conveyors

Feeding, washing and sorting processes require reliable, robust products designed for conveyor systems. Regardless of the type of machine used for this first handling phase, Bonfiglioli can provide solutions that perfectly meet our customers' need for dynamics, space and efficiency.

Our customers can also rely on a product line specifically conceived for applications involving frequent washing procedures and humid environments.

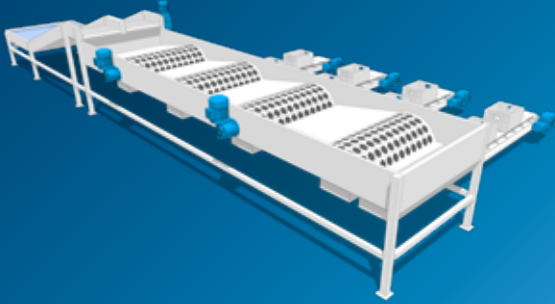

## VF/EP Series

Worm gearbox and geared motors with enhanced protection

### Benefits

- Price effective
- Uncompromising quality
- Various mounting options, shaft configurations and motor

### Features

- Epoxy coating (NSF & FDA approved for incidental food contact)
- AISI 316 stainless steel output shaft and stainless steel fasteners
- H1 food grade lubricant
- High and premium efficiency motors (IE2, IE3)
- Rain canopy to protect motor from water
- Tropicalized windings
- Front and rear end-shield condensation drain
- Surface protection class C5 (according to standard UNI EN ISO 12944-2)





## Processing Crushers

2

The crushing phase is crucial to any fruit and beverage process. We supply gearmotors specifically designed to allow crushing systems smooth, efficient and continuous operation.

### C Series

#### Helical in-line gearbox and geared motor

##### Benefits

- Excellent torque density
- Ultra-compact design
- Very wide speed range

##### Features

- Extensive choice of bolt-on output flanges
- Special seals set for applications in harsh environments
- Surface protection class C3, C4 and C5 (according to standard UNI EN ISO 12944-2)
- High and premium efficiency motors (IE2, IE3)
- Motor shaft extension
- Tropicalized windings



### Agile Series Smart inverter

##### Benefits

- Smooth start
- Variable "cut position" for smaller particles
- Energy saving function: current consumption redirection during start phase

##### Features

- Series optionally extendable for field bus communication
- Sensorless control of synchronous and asynchronous motors
- Modbus and Systembus onboard
- DC link connection
- Integrated brake chopper
- Power failure control
- Programmable PI Controller
- Integrated VPLC
- Master/slave function with electronic gear
- Integrated safe torque off STO (SIL 2 / PL d) function
- Energy Saving function
- Intelligent current limits
- Output frequency 0...599 Hz, higher frequencies on request
- Diagnosis and setup via integrated keypad and integrated Service interface for PC connection



# Fruit & Beverage Processing



## Mixing

### Mixer, kneader

3

Bonfiglioli solutions are suitable for both liquid and solid mixing. Mixing applications involve a tough work cycle. To ensure process continuity, the drive's reliability must be extremely high. To achieve this, solutions from Bonfiglioli feature special seals, surface protection and bearings. The seals prevent contamination and protect the gearmotors from aggressive agents, while the surface protection and bearings extend the gearmotor's life.

## HD Series

### Heavy duty gearbox

#### Benefits

- Solution co-engineered with customer
- Enhanced oil leak protection
- High radial & axial load on output shaft
- Extended reliability and lifetime
- Quiet operation
- High torque capability

#### Features

- Reinforced bearing and extended span on output shaft
- Integrated forced oil lubrication
- Back stop device option
- Drywell option
- High and premium efficiency motors (IE2, IE3)
- Insulation class F (standard) or H (available on request)
- Thermal protection (bi-metallic, PTC or KTY)



## Active Cube Series

### Premium inverter

#### Benefits

- Smooth start
- Torque control
- Motor temperature monitoring

#### Features

- Series optionally extendable for field bus communication and encoder evaluation
- Plug-in power terminals (up to 3kW)
- Plug-in and programmable control terminals
- DC link connection
- Integrated brake chopper
- Positioning function via field bus (Motion Control compatible to CiA DS402)
- Integrated VPLC
- Master/slave function with electronic gear
- Power failure control
- Integrated safe torque off STO (SIL 3 / PL e) function
- Output frequency 0...599 Hz, higher frequencies on request
- Diagnosis and setup via optional keypad or PC software



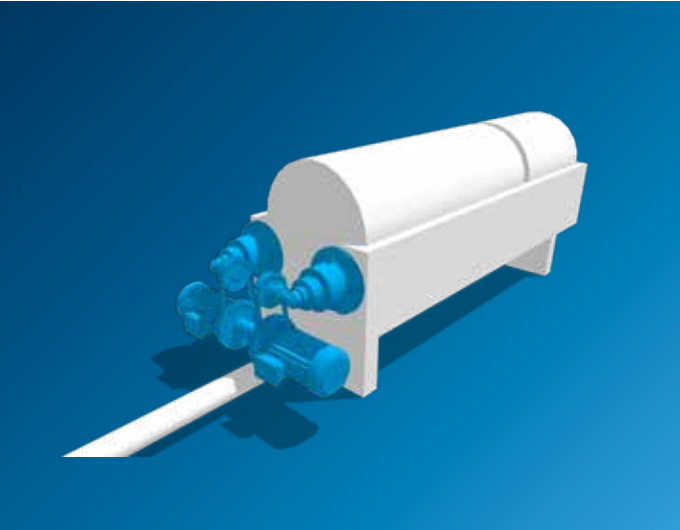

## Pressing line

### Extraction, squeezing

4

During pressing, material must be slowly compressed to remove excess water. One key aspect of this application is therefore the pressing speed. Bonfiglioli products' modularity allows customers to find the right extraction speed for all their applications.

## 300M Series

### Planetary gearbox and geared motor

#### Benefits

- High shock load capability
- Modular design
- Flexible drive layout and mounting

#### Features

- In-line or right angle layout solution
- Shock load up to 2,000,000 Nm
- Surface protection class C3, C4 and C5 (according to standard UNI EN ISO 12944-2)
- High and premium efficiency motors (IE2, IE3)
- Protection rating up to IP56
- Thermal protection (bi-metallic, PTC or KTY)
- Tropicalized windings



# Complete solutions for Power Transmission & Automation

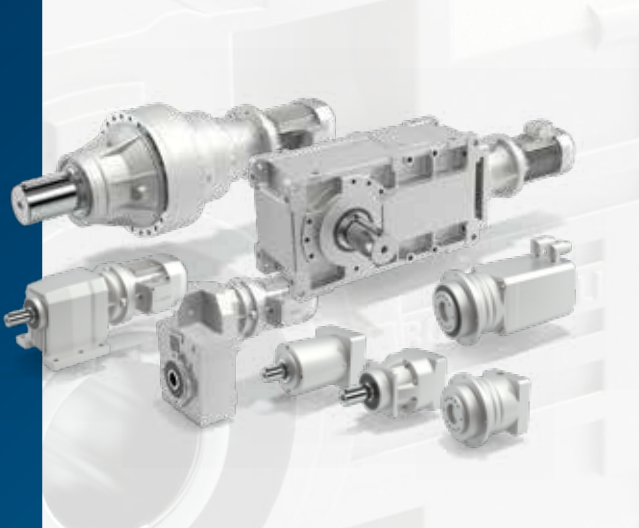

## Gearboxes & Geared motors

- **Heavy duty parallel/right angle shaft geared motors**  
**HDP/HDO Series**  
Torque range: 13 to 7,100 Nm  
Gear ratios: 7 to 10,000
- **Planetary geared motors** | **300 Series**  
Torque range: 1,250 to 1,287,000 Nm  
Gear ratios: 3.4 to 5,234

- **Worm geared motors** | **W/VF Series**  
Torque range: 13 to 7,100 Nm  
Gear ratios: 7 to 10,000
- **Helical geared motors** | **C Series**  
Torque range: 45 to 12,000 Nm  
Gear ratios: 2.6 to 1,481
- **Bevel-helical geared motors** | **A Series**  
Torque range: 100 to 14,000 Nm  
Gear ratios: 5.4 to 1,715
- **Shaft-mounted geared motors** | **F Series**  
Torque range: 140 to 14,000 Nm  
Gear ratios: 6.4 to 2,099

- **Precision planetary servo geared motors**  
**TQ, TQK, TQF, TR, MP, LC, LCK, SL, KR Series**  
Torque range: up to 1,000 Nm  
Gear ratios: up to 1,000  
Backlash: lower than 2 and 17 arcmin

## Motors

- **Asynchronous IEC Motor** | **BN, BE, BX Series**  
**Asynchronous Compact Motors** | **MN, ME, MX Series**  
A complete range of AC motors, meeting worldwide MEPS (e.g. IE3)  
Power range: 0.06 to 355 kW  
Poles: from 2 to 8 and multiple poles

IE3

- **Asynchronous motors** | **BN, BE, BX, M, ME, MX Series**  
A complete range of AC motors, meeting worldwide MEPS (e.g. IE3)  
Power range: 0.06 to 355 kW  
Poles: from 2 to 8 and multiple poles

IE3

- **Synchronous motors** | **BMD Series**  
Stall torque: 0.85 to 60 Nm  
Rated speed: from 1,600 to 6,000 min<sup>-1</sup>  
Power supply: 230, 400 VAC

- **Synchronous reluctance motor** | **BSR Series**  
Two different versions for different needs: High efficiency IE4 and high output  
Power range: 0.37 to 18.5 kW

IE3

- **Synchronous motors** | **BMD, BCR Series**  
Stall torque **BMD**: 0.85 to 60 Nm  
Stall torque **BCR**: 0.2 to 115 Nm  
Rated speed **BMD**: from 1,600 to 6,000 min<sup>-1</sup>  
Rated speed **BCR**: from 2000 to 4500 min<sup>-1</sup>  
Power supply: 230, 400 VAC
- **Synchronous motors with integrated drives** | **iBMD Series**  
Stall Torque: 2.7 to 36 Nm  
Rated speed: 3,000 min<sup>-1</sup>  
Power supply: 560 VDC



## Inverters

- **Cabinet solution | Active Cube 8 IP 54**

**Power range:** 200 up to 1,200 kW  
**Voltage:** 400 V, 525V, 690V

- **Premium inverter | Active Cube Series**

**ACU210:** 0,25 - 9,2 kW / 1- or 3-phase | **ACU410\*:** 0,25 - 400 kW / 3-phase  
**ACU510\*:** 160 - 400 kW / 3-phase | **ACU610\*:** 160 - 400 kW / 3-phase

- **Premium inverter | Active Cube Series**

**ACU210:** 0,25 - 9,2 kW / 1- or 3-phase | **ACU410\*:** 0,25 - 400 kW / 3-phase  
**ACU510\*:** 160 - 400 kW / 3-phase | **ACU610\*:** 160 - 400 kW / 3-phase

- **Smart inverter | Agile Series**

**200V:** 1-phase 0.12 up to 3 kW / 3-phase 0.25 up to 7.5 kW  
**400V:** 0.25 up to 11 kW

- **Compact inverter | S2U Series**

**S2U230S--(F) IP66:** 0.2 - 2.2 kW / 1-phase

- **Servo inverter | ANG Series**

**ANG210:** 0.25 - 9.2 kW / 1- or 3-phase | **ANG410\*:** 0.25 - 400 kW / 3-phase  
**ANG510\*:** 160 - 400 kW / 3-phase | **ANG610\*:** 160 - 400 kW / 3-phase

- **Premium inverter | Active Cube Series**

**ACU210:** 0,25 - 9,2 kW / 1- or 3-phase | **ACU410\*:** 0,25 - 400 kW / 3-phase  
**ACU510\*:** 160 - 400 kW / 3-phase | **ACU610\*:** 160 - 400 kW / 3-phase

- **Smart inverter | Agile Series**

**202V:** 0.12 - 3 kW / 1-phase | 0.25 - 7.5 kW / 3-phase  
**402V:** 0.25 - 11 kW / 3-phase

\* up to 1200 kW with parallel connection



## HMI

- **Human Machine Interfaces | BMI Series**

3 Display sizes 3.5", 7", 10.1"  
 True flat front panel in IP65  
 High resolution 480x272 up to 1,024x600 pixels

- **Human Machine Interfaces | BMI Series**

3 Display sizes 3.5", 7", 10.1"  
 True flat front panel in IP65  
 High resolution 480x272 up to 1,024x600 pixels

- **Human Machine Interfaces | BMI Series**

3 Display sizes 3.5", 7", 10.1"  
 True flat front panel in IP65  
 High resolution 480x272 up to 1,024x600 pixels

# Research & Development



Bonfiglioli's global research and development create breakthrough solutions that integrate the most advanced mechanical, electrical and hydraulic technologies. They meet the most demanding application requirements and support our customers' growth.

More than 200 employees around the world are involved in the group's research and development.



DESIGN YOUR  
SOLUTIONS



CO-  
ENGINEERING

## We support our customers' projects from beginning to end.

At Bonfiglioli, we believe that product development relies on passion, efficient processes, and the ability to understand our customers' needs accurately.

First, our team identify the customer's needs after in-depth analysis drawn from our specific application expertise.

Through dedicated calculation tools, we can simulate the transmission's capabilities and performance allowing reducing development time.

The alignment phase allows us then to adapt our proposal according to key factors of performance, installation and maintenance.



### The test centers at Bonfiglioli

Bonfiglioli's test laboratories develop, certify and perform production follow-up for the solutions designed and manufactured in our plants across the world.

Our specialists are true partners to the R&D, technical and quality departments. They help validate each Bonfiglioli product from the smallest critical component to the overall solution.

The test centers regularly conduct additional tests to ensure gearbox durability and confirm the specifications declared during the official approval stage.



# Quality, Health & Safety



Our team is wholly dedicated to continuous improvement in the quality, safety and environmental sphere, throughout the entire value chain, from the smallest supplier to the end client.

Bonfiglioli management systems are certified ISO 9001: 2015, ISO 14001: 2015 and OHSAS 18001: 2007, while our products are covered by 7 international certifications. Responsibility, excellence and continuous improvement are the basic elements that make us the favored partner of our clients and suppliers.



SYSTEM  
CERTIFICATION



PRODUCTS  
CERTIFICATION

## Quality

Bonfiglioli is committed to achieving the highest ethical and quality standards. These standards are documented in the Bonfiglioli Quality Management System.

Our products are intended to generate value for our customers. We are committed to designing, manufacturing and supplying effective products and services that set a benchmark for quality in the industry.

Based on defined procedures and instructions, the Bonfiglioli Quality Management System has been established not only to ensure the ongoing quality of our products and processes, but also to guarantee continuous improvement.

Bonfiglioli has also implemented a Quality Policy which sets customer focus as a primary goal. The Quality Policy is used to set and deploy goals and objectives at every level of the organization. The fulfilment of these objectives is measured on a regular basis with appropriate performance indicators.



## Health & Safety: Sustainability starts with safety

Prevention of accidents and incidents is a key element of our company's sustainable strategy and an integral part of each one of our business processes. The successful management of risks is essential for protecting our employees and assets and thereby contribute therefore strengthening.



# Global Presence



Bonfiglioli is a market force with a presence spanning 22 countries on 5 continents. Our organization makes the most of geographic proximity to offer complete solutions combining efficiency and competence.



3700  
EMPLOYEES



21  
BRANCHES



14  
PLANTS



550  
DISTRIBUTORS



80  
COUNTRIES

## We Are a Global Company

Thanks to an international network of sales branches and closely interconnecting production plants, we can guarantee the same high standards of Bonfiglioli quality anywhere at any given time. Aware that our direct presence in local markets is the key to long-lasting success, our family includes 21 sales branches, 14 production plants and more than 500 distributors around the world.

**Our organization is always close by, offering complete and efficient solutions and supporting our customers with dedicated services, such as co-engineering or after-sales assistance.**



# Bonfiglioli Worldwide Locations

## Australia

### **Bonfiglioli Transmission (Aust.) Pty Ltd**

2, Cox Place Glendenning NSW 2761  
Locked Bag 1000 Plumpton NSW 2761  
Tel. +61 2 8811 8000

## Brazil

### **Bonfiglioli Redutores do Brasil Ltda**

Travessa Cláudio Armando 171 - Bloco 3 - CEP 09861-730  
Bairro Assunção - São Bernardo do Campo - São Paulo  
Tel. +55 11 4344 2322

## China

### **Bonfiglioli Drives (Shanghai) Co. Ltd.**

#68, Hui-Lian Road, QingPu District,  
201707 Shanghai  
Tel. +86 21 6700 2000

## France

### **Bonfiglioli Transmission s.a.**

14 Rue Eugène Pottier  
Zone Industrielle de Moimont II - 95670 Marly la Ville  
Tel. +33 1 34474510

## Germany

### **Bonfiglioli Deutschland GmbH**

Sperberweg 12 - 41468 Neuss  
Tel. +49 0 2131 2988 0

### **Bonfiglioli Vectron GmbH**

Europark Fichtenhain B6 - 47807 Krefeld  
Tel. +49 0 2151 8396 0

### **O&K Antriebstechnik GmbH**

Ruhrallee 8-12 - 45525 Hattingen  
Tel. +49 0 2324 2050 1

## India

### **Bonfiglioli Transmission Pvt Ltd**

Plot No. AC7-AC11, SIDCO Industrial Estate,  
Thirumudivakkam - 600 044 Chennai  
Tel. +91 44 2478 1035

### **Industrial**

Survey No. 528, Porambakkam High Road,  
Mannur Village, Sriperambudur Taluk - 602 105 Chennai  
Tel. +91 44 6710 3800  
Plot No. A-95, Phase IV, MIDC Chakan, Village Nighoje  
Pune, Maharashtra - 410 501

## Italy

### **Bonfiglioli Riduttori S.p.A.**

#### **Headquarters**

Via Giovanni XXIII, 7/A - 40012 Lippo di Calderara di Reno  
Tel. +39 051 647 3111

#### **Mobile, Wind**

Via Enrico Mattei, 12 Z.I. Villa Selva - 47100 Forlì  
Tel. +39 0543 789111

#### **Industrial**

Via Bazzane, 33/A - 40012 Calderara di Reno  
Tel. +39 051 6473111  
Via Trinità, 1 - 41058 Vignola  
Tel. +39 059 768511

### **Bonfiglioli Italia S.p.A**

Via Sandro Pertini lotto 7b - 20080 Carpiano  
Tel. +39 02 985081

### **Bonfiglioli Mechatronic Research S.p.A**

Via F. Zeni 8 - 38068 Rovereto  
Tel. +39 0464 443435/36

## New Zealand

### **Bonfiglioli Transmission (Aust.) Pty Ltd**

88 Hastie Avenue, Mangere Bridge, 2022 Auckland  
PO Box 11795, Ellerslie  
Tel. +64 09 634 6441

## Singapore

### **Bonfiglioli South East Asia Pte Ltd**

24 Pioneer Crescent #02-08  
West Park Bizcentral - Singapore, 628557  
Tel. +65 6268 9869

## Slovakia

### **Bonfiglioli Slovakia s.r.o.**

Robotnícka 2129  
Považská Bystrica, 01701 Slovakia  
Tel. +421 42 430 75 64

## South Africa

### **Bonfiglioli South Africa Pty Ltd**

55 Galaxy Avenue, Linbro Business Park - Sandton  
Tel. +27 11 608 2030

## Spain

### **Tecnotrans Bonfiglioli s.a**

Pol. Ind. Zona Franca, Sector C, Calle F, nº 6  
08040 Barcelona  
Tel. +34 93 447 84 00

## Turkey

### **Bonfiglioli Turkey Jsc**

Atatürk Organize Sanayi Bölgesi, 10007 Sk. No. 30  
Atatürk Organize Sanayi Bölgesi, 35620 Çiğli - Izmir  
Tel. +90 0 232 328 22 77

## United Kingdom

### **Bonfiglioli UK Ltd.**

1 Calver Quay, Winwick  
Warrington - WA2 8UD  
Tel. +44 1925 825667

## USA

### **Bonfiglioli USA Inc.**

3541 Hargrave Drive  
Hebron, Kentucky 41048  
Tel. +1 859 334 3333

## Vietnam

### **Bonfiglioli Vietnam Ltd**

Lot C-9D-CN My Phuoc Industrial Park 3  
Ben Cat - Binh Duong Province  
Tel. +84 650 3577411



We have a relentless commitment to excellence, innovation and sustainability. Our team creates, distributes and services world-class power transmission and drive solutions to keep the world in motion.

#### **HEADQUARTERS**

Bonfiglioli Riduttori S.p.A.  
Via Giovanni XXIII, 7/A  
40012 Lippo di Calderara di Reno  
Bologna (Italy)  
[www.bonfiglioli.com](http://www.bonfiglioli.com)

