

# Product Range

O&K Antriebstechnik



MOBILITY & WIND  
INDUSTRIES





# O&K Antriebstechnik



## Travel drives

- F series
- FP series
- FK series
- FR series

## Slew drives

- S series

## Cutter drives

- FA series

## Winch drives

- FW series

## Other drives

- FTU series
- Jack-Up series

## The widest range of final drives on the market

With over 140 years of history, O&K Antriebstechnik is a centre of engineering excellence, recognized worldwide for high quality products for applications in the mining, construction and marine & offshore industries.

Acquired by Bonfiglioli Group in 2016, this leading brand develops, manufactures and offers a full range of final drives such as slew drives, travel drives, winch drives and cutter drives.

The origins of the company date back to the founders, Benno Orenstein and Arthur Koppel, who at the end of the 19th century began – in the middle of the Ruhr – to develop railway systems for foundries and mines. Gradually, O&K became the benchmark for heavy-duty machines and the best-known brand in the world for the design and manufacture of excavators and mining shovels.

Today, O&K is recognized for its solid expertise, its capacity to adapt the design of its products depending on customers' requirements and the high technological standards of development.

O&K Antriebstechnik provides solutions for:

 CONSTRUCTION

 MARINE & OFFSHORE

 MINING



# Travel drives



## F Series

### Small final drives

The F Series is perfectly suited to any crawler and milling machine. Thanks to compact, rugged design, high torque and load capabilities, these solutions are the best possible option for these machines. All units are available with a fail-safe parking brake and for most cartridge type fixed or variable systems. Different disengagement systems are available on demand for all the sizes.



HYDRAULIC SOLUTIONS

### Gear ratios

- 19 ... 305

### Standard features

- Compact structure
- High performance
- 3-7 Planetary wheels per stage
- Notchless ground tooth root
- Different ratios
- Integrated disc-brake

### Special executions on request

- Mechanical disconnect device
- Low and high temperature version

### Torque (kNm)



*Stated torques are peak values for short duration.*

## Overall dimensions and technical data

Type	Ratio <sup>2</sup>	Capacity of Bearing		Weight <sup>4</sup>	Multi-disk brake			
		C-dynamic	Co-static		Locking torque	Release pressure min.	Hydraulic motor plug in fixed	Plug-in variable
	i	kN	kN	kg	Nm	bar	ccm	ccm
F13A	93 (41) <sup>1</sup> -108-122-140-178-229	132	255	50	200	17	28-30-32	28-45
FD20	81-90-101-137-171-228	194/194	325/315	72	300	16	28-30-32	28-45
F30	61 (19) <sup>1</sup> -66 (32) <sup>1</sup> -81-90-101-114-121-137-171-228-305	132/194	255/325	94	300 (255; 400) <sup>3</sup>	16 (16; 22) <sup>3</sup>	28-30-32-40-45-56-60-63	28-45-55-60

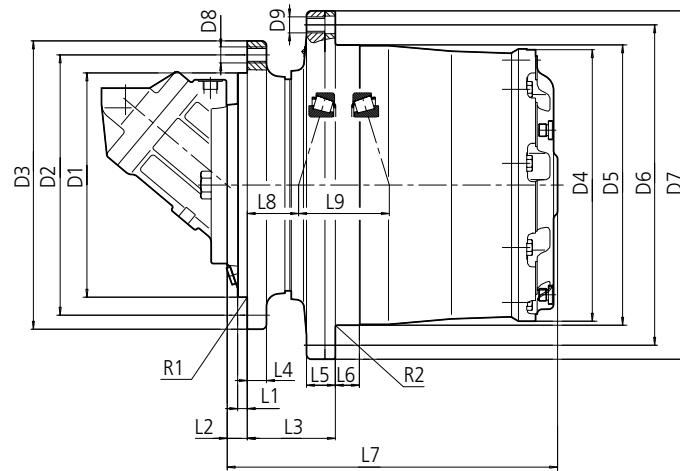

Type	L1	L2	L3	L4	L5	L6	L7	L8	L9	R1	R2	D1	D2	D3	D4	D5	D6	D7	D8	D9	Qty. D8/D9
F13A	10	30	72	13.5	15	16	255	28	79	0.6	0.6	190	230	256	216	220	260	290	M16x2	M16x2	12/8
FD20	10	41	75	15	28	25	300	15.3	86.3	2.5	2.5	240	275	304	250	270	305	335	M16x2	M16x2	18/18
F30	13	25/22	75	15	29	25	323/320	28.5	89	2.5	2.5	240	275	304	269	270	305	335	M16x2	M16x2	18/18

1) 2-stage

2) Other ratios on demand

3) Optional brake torques

4) Without Hydraulic motor

# Travel drives



## F Series Medium final drives

The F Series is perfectly suited to any crawler and milling machine. Thanks to compact, rugged design, high torque and load capabilities, these solutions are the best possible option for these machines. All units are available with a fail-safe parking brake and for most cartridge type fixed or variable systems. Different disengagement systems are available on demand for all the sizes.



HYDRAULIC SOLUTIONS

### Gear ratios

- 16 ... 226

### Standard features

- Compact structure
- High performance
- 3-7 Planetary wheels per stage
- Notchless ground tooth root
- Different ratios
- Integrated disc-brake

### Special executions on request

- Mechanical disconnect device
- Low and high temperature version

### Torque (kNm)

F40	40
F40A	40
F55	55
F55A	55
F55B	55
F80	80
F80XR	80
F100	100
F100XR	100

*Stated torques are peak values for short duration.*

## Overall dimensions and technical data

Type	Ratio <sup>2</sup>	Capacity of Bearing		Weight <sup>4</sup>	Park Brake		Hydraulic Motor	
		C-dynamic	Co-static		Locking torque	Release pressure min.	Plug-in fixed	Plug-in variable
	i	kN	kN	kg	Nm	bar	ccm	ccm
F40	61 (19) <sup>1</sup> -66 (22) <sup>1</sup> -81 (32) <sup>1</sup> -85-101-110-117-124-142-181	224	405	115	420	18	40-45-56-60-63	55-60
F40A		224	405	123	420	18	80-90	80
F55	63 (16) <sup>1</sup> -68 (19) <sup>1</sup> -87 (22) <sup>1</sup> -94 (32) <sup>1</sup> -103-117-124-137-148-185	224	405	165	420 (390; 500) <sup>3</sup>	15 (15; 21) <sup>3</sup>	80-90	80
F55A		224	405	177	420 (390; 500) <sup>3</sup>	15 (15; 21) <sup>3</sup>	40-45-56-60-63	55-60
F55B		224	405	181	420 (390; 500) <sup>3</sup>	15 (15; 21) <sup>3</sup>	-	107-110
F80	61 (19) <sup>1</sup> -81 (32) <sup>1</sup> -101-114-121-137-147-171-187-206	300	570	230	600 (375; 550; 1000) <sup>3</sup>	18 (18; 19; 28) <sup>3</sup>	80-90-107-110-125-160-180	80-107-110-160
F80XR		300	570	240	600	18	80-90-107-110-160-180	
F100	77 (21) <sup>1</sup> -84 (22) <sup>1</sup> -95 (32) <sup>1</sup> -121-142-175-192-226	498	1,010	330	600 (900) <sup>3</sup>	15 (13) <sup>3</sup>	107-125-160-180	107-110-160
F100XR		498	1,010	341	600	15		

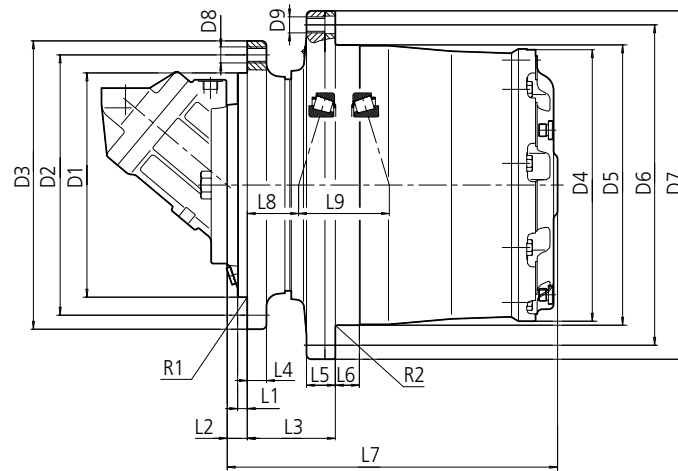

Type	L1	L2	L3	L4	L5	L6	L7	L8	L9	R1	R2	D1	D2	D3	D4	D5	D6	D7	D8	D9	Qty. D8/D9
F40	16	16	91	21	34	26	338	38	100	2.5	2.5	240	285	320	294	295	335	370	M20x1.5	M20x1.5	20/20
F40A	13	35	91	21	34	26	357	38	100	2.5	2.5	270	310	345	294	295	335	370	M20x1.5	M20x1.5	16/20
F55	12	25	110	24	36	30	413	64	113	1	2.5	280	325	360	340	350	400	435	M20x1.5	M20x1.5	24/20
F55A	20	30	91	24	36	30	399	45	113	4	2.5	240	285	320	340	350	40	435	M20x1.5	M20x1.5	20/20
F55B	12	37	110	24	36	30	425	64	113	1	2.5	290	335	370	340	350	400	435	M20x1.5	M20x1.5	20/20
F80	20	35	90	22	37	24	415	34	123	4	2.5	330	370	410	374	400	450	490	M24x2	M24x2	20/20
F80XR	20	35	90	22	37	23	414.5	68.5	123	4	2.5	330	370	410	374	400	450	490	M20x1.5	M20x1.5	20/20
F100	35/37	35/37	165	28	53	43	461/463	32	139	10 (12)/60	5	390	460	500	407	408	460	500	M24x2	M24x2	30/24
F100XR	22	35	148	29	53	30	463	32	139	2.5	2.5	380	430	480	407	430	480	500	M24x3	M24x3	20/20

1) 2-stage

2) Other ratios on demand

3) Optional brake torques

4) Without Hydraulic motor

# Travel drives



## F Series

### Large final drives

The F Series is perfectly suited to any crawler and milling machine. Thanks to compact, rugged design, high torque and load capabilities, these solutions are the best possible option for these machines. All units are available with a fail-safe parking brake and for most cartridge type fixed or variable systems. Different disengagement systems are available on demand for all the sizes.



HYDRAULIC SOLUTIONS

### Gear ratios

- 14 ... 1784

### Standard features

- Compact structure
- High performance
- 3-7 Planetary wheels per stage
- Notchless ground tooth root
- Different ratios
- Integrated disc-brake
- Different hydraulic motors

### Special executions on request

- Mechanical disconnect device
- Low and high temperature version

### Torque (kNm)

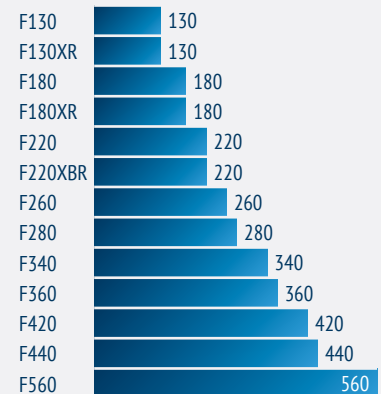

*Stated torques are peak values for short duration.*



## Overall dimensions and technical data | F130 ... F180XR

Type	Ratio <sup>2</sup>	Version <sup>4</sup>	Capacity of Bearing		Weight <sup>5</sup>	Park Brake		Hydraulic Motor	
			C-dynamic	Co-static		Locking torque	Release pressure min.	Plug-in fixed	Plug-in variable
	i		kN	kN	kg	Nm	bar	ccm	ccm
F130	69 (14) <sup>1</sup> -81 (18) <sup>1</sup> -85 (21) <sup>3</sup> -95 (26) <sup>3</sup> -115-159-167-180-206	ST	523	980	452	750	19	107-125-160-180	107-160
F130XR	81-85-115-159-167-180-206	ST	-	-	465	750	19		
F180	206-281-(412) <sup>6</sup> -(618) <sup>6</sup> -(824) <sup>6</sup>	ST	787	1,650	636	1375 (800) <sup>3</sup>	35 (35) <sup>3</sup>	160-180	160
		CC	787	1,650	636	1375 (800) <sup>3</sup>	35 (35) <sup>3</sup>	180	-
F180XR		ST	787	1,650	636	1375 (800) <sup>3</sup>	35 (35) <sup>3</sup>	160-180	-

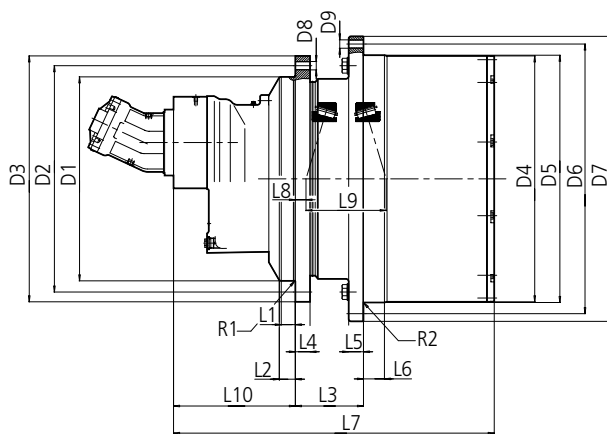

Standard input version - ST

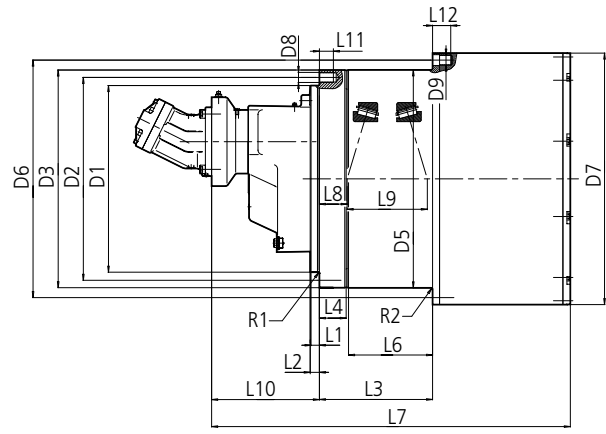

Crawler crane version - CC

Type		L1	L2	L3	L4	L5	L6	L7	L8	L9	L10	L11	L12	R1	R2	D1	D2	D3	D4	D5	D6	D7	D8	D9	Qty. D8/D9
F130	ST	45	45	190	35	58	45	530	50.5	147	-	-	-	25	4	390	500	550	449	450	500	550	M24x2	M24x2	32/32
F130XR	ST	20	70	165	35	58	45	532	25	147	-	-	-	1.2	1.2	420	460	500	449	460	500	540	M24x3	M18x1.5	24/36
F180	ST	30	30	168	40	56	21.5	534.5	50.3	141.4	-	-	-	4	3	450	510	560	528	535	600	650	M24x2	M27x2	30/30
	CC	25	30	171	80	-	86	564.5	80.3	141.4	-	35	81.5	4	5	340	400	444	-	445	495	528	M33x1.5	M27x2	24/30
F180XR	ST	30	30	168	40	56	21.5	534.5	50.3	141.4	-	-	-	4	3	450	510	560	528	535	600	650	M24x2	M24x2	30/30

1) 2-stage on demand  
2) Other ratios on demand

3) Optional brake torques  
4) ST= Standard CC= Crawler Crane

5) Without hydraulic motor  
6) In combination with input bevel drive

# Travel drives

## Overall dimensions and technical data | F220 ... F280

Type	Ratio <sup>2</sup>	Version <sup>4</sup>	Capacity of Bearing		Weight <sup>5</sup>	Park Brake		Hydraulic Motor	
			C-dynamic	Co-static		Locking torque	Release pressure min.	Plug-in fixed	Plug-in variable
	i		kN	kN	kg	Nm	bar	ccm	ccm
F220	97 (298) <sup>6</sup> -119 (372) <sup>6</sup> -120 (572) <sup>6</sup> -190 (744) <sup>6</sup> -248 (805) <sup>6</sup> -290-345	ST	765	1,660	740	1,200	15	107-180	160-200-215-250-280
		CC	750	1,560	895	1,000	15	107-180	160
F220XBR	97-119-190-248-290-345	ST	-	-	800	1,200	15	107-180	160-200-215-250-280
F260	69-97-168-245-345-(670) <sup>6</sup> -(1115) <sup>6</sup> -(1784) <sup>6</sup>	ST	750	1,560	865	1,000	15	-	355-250
		CC	750	1,560	895	1,000	15	-	160
F280	201	ST	1,180	2,600	1,037	1,650	15	-	250

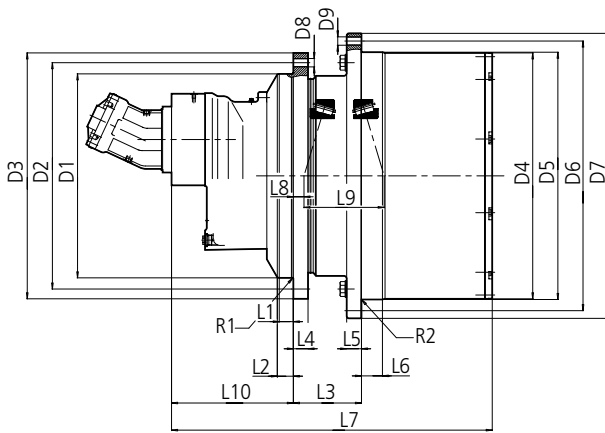

Standard input version - ST

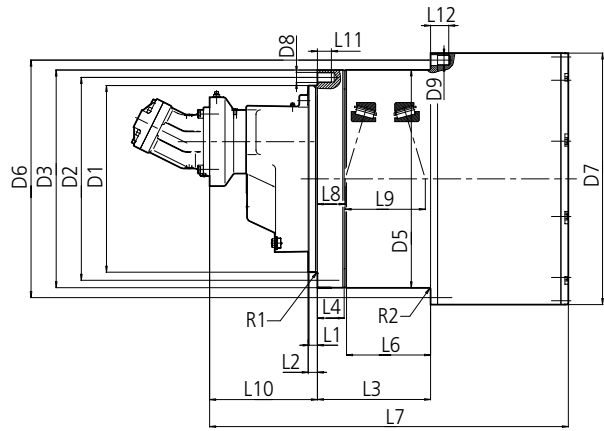

Crawler crane version - CC

Type		L1	L2	L3	L4	L5	L6	L7	L8	L9	L10	L11	L12	R1	R2	D1	D2	D3	D4	D5	D6	D7	D8	D9	Qty. D8/D9
F220	ST	18	52	166.5	40	61	35	580.5	16	187.5	-	-	-	35°/16/16	4	460	600	650	540	542	600	650	M24x2	M24x2	38/38
	CC	21	25	165.5	54	-	106.5	631.5	42	189.5	-	54	75	-	4	428	474	521	-	523	570	608	M30x2	M24x1.5	30/36
F220XBR	ST	52	52	170	40	40	50	580.5	16	187.5	-	-	-	2.5	-	460	600	650	538	610	680	735	M30x3.5	M30x3.5	30/24
F260	ST	21	45	170	40	48	60	579	18.5	189.5	-	-	-	2	-	460	520	570	608	610	680	735	M30x2	33	24/24
	CC	21	25	165.5	54	-	106.5	631.5	42	189.5	-	54	75	-	4	428	474	521	-	523	570	608	M30x2	M24x1.5	30/36
F280	ST	52	125	125	40	65	45	627	89.3	180.4	-	-	-	18°/50/5	4	530	630	685	608	610	685	740	M30x3.5	M30x3.5	28/28

1) 2-stage on demand  
2) Other ratios on demand

3) Optional brake torques  
4) ST= Standard CC= Crawler Crane

5) Without hydraulic motor  
6) In combination with input bevel drive

## Overall dimensions and technical data | F340 ... F560

Type	Ratio <sup>2</sup>	Version <sup>4</sup>	Capacity of Bearing		Weight <sup>5</sup>	Park Brake		Hydraulic Motor	
			C-dynamic	Co-static		Locking torque	Release pressure min.	Plug-in fixed	Plug-in variable
	i		kN	kN	kg	Nm	bar	ccm	ccm
F340	257	ST	1,040	2,450	976	1,700	12	-	-
F360	94 (385) <sup>6</sup> -128 (446) <sup>6</sup> -161 (670) <sup>6</sup> -168 (848) <sup>6</sup> -186 (1115) <sup>6</sup> -223 (1784) <sup>6</sup> -242-257-283-490	ST	1,040	2,450	1,080	1,700	12	355	355
F420	259	ST	1,120	2,555	1,500	1,000	18	-	(2x) 160
F440	352-555-637-(445) <sup>6</sup> -(528) <sup>6</sup> -(705) <sup>6</sup>	CC	1,040	2,450	1,300	1700 (1000)*	15 (7.8)*	-	250-160
F560	357-739-(887) <sup>6</sup>	CC	1,040	2,450	2,000	900	13	-	160

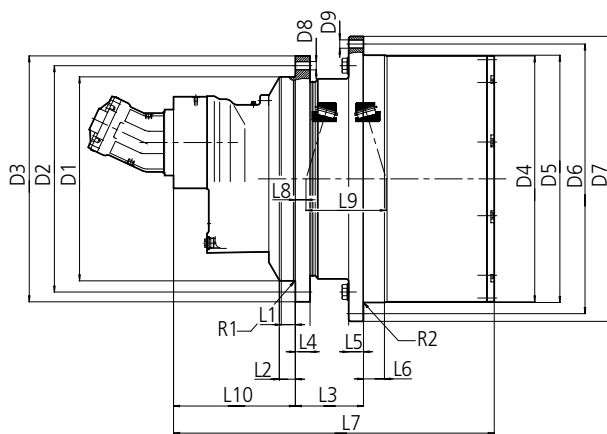

Standard input version - ST

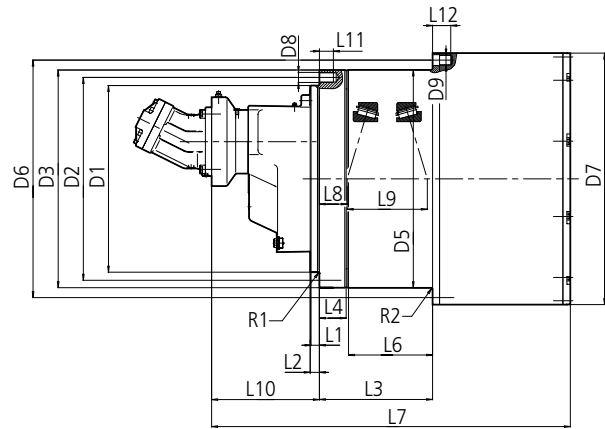

Crawler crane version - CC

Type	L1	L2	L3	L4	L5	L6	L7	L8	L9	L10	L11	L12	R1	R2	D1	D2	D3	D4	D5	D6	D7	D8	D9	Qty. D8/D9
F340	100	100	130	40	60	80	697,5	75	214,8	-	-	-	18°/100/16	10	580	680	735	649,5	650	720	775	M30x3,5	M30x3,5	30/30
F360	100	100	130	40	60	80	658	25	215	-	-	-	18°/100/16	10	580	680	735	649	650	720	775	M30x3,5	M30x3,5	30/30
F420	60	132	130	40	60	80	1026	43,5	210,7	-	-	-	10	10	660	744	795	670	674	744	795	M30x2	M30x2	42/42
F440	40	43	255	40	25	25	820	80	213	-	40	70	4	4	450	515	569	669	570	620	670	M36x3	M30x3	30/30
F560	40	43	255	45	45	120	831,5	80	213	-	45	70	4	4	450	515	569	763	570	620	670	M36x1,5	M30x1,5	29/42

\* Park brake integrated in hydraulic motor

- 1) 2-stage on demand
- 2) Other ratios on demand

3) Optional brake torques

4) ST= Standard CC= Crawler Crane

5) Without hydraulic motor

6) In combination with input bevel drive

# Travel drives



## F Series

### XLarge final drives

The F Series is perfectly suited to any crawler and milling machine. Thanks to compact, rugged design, high torque and load capabilities, these solutions are the best possible option for these machines. All units are available with a fail-safe parking brake and for most cartridge type fixed or variable systems. Different disengagement systems are available on demand for all the sizes.



HYDRAULIC SOLUTIONS

### Gear ratios

- 249 ... 989

### Standard features

- Compact structure
- High performance
- 3-7 Planetary wheels per stage
- Notchless ground tooth root
- Different ratios
- Integrated disc-brake
- Suitable for various hydraulic motors

### Special executions on request

- Mechanical disconnect device
- Low and high temperature version

### Torque (kNm)

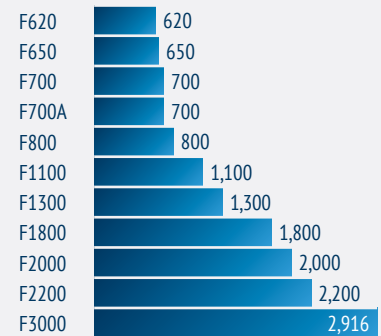

*Stated torques are peak values for short duration.*

## Overall dimensions and technical data | F620 ... F700A

Type	Ratio <sup>1</sup>	Version <sup>2</sup>	Capacity of Bearing		Weight <sup>3</sup>	Park Brake		Hydraulic Motor	
			C-dynamic	Co-static		Locking torque	Release pressure min.	Plug-in fixed	Plug-in variable
	i		kN	kN	kg	Nm	bar	ccm	ccm
F620	249-293-328-462	ST	1,320	3,150	2,897	1,200	28	(2x) 250-(1x) 500	(2x) 250-(2x) 280-(1x) 500
		CC	1,320	3,150	2,897	1,200	28	(2x) 200-(2x) 160	(2x) 160
F650	682	CC	1,040	2,450	1,660	1,150	17	-	(2x) 215
F700	377	CC	1,320	3,150	3,350	1,200	28	(2x) 250	(2x) 250-(2x) 280
F700A	648	CC	1,320	3,150	3,350	1,200	28	-	(2x) 160

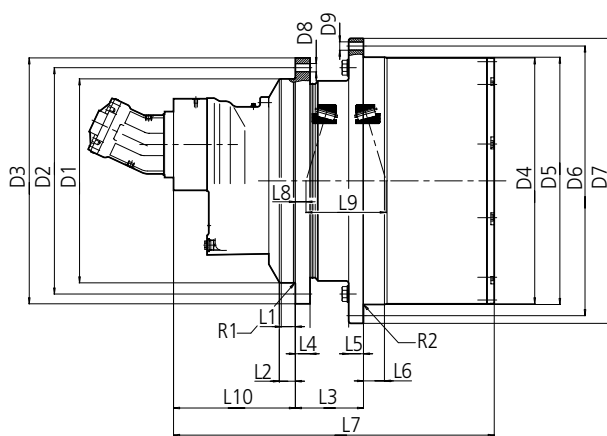

Standard input version - ST

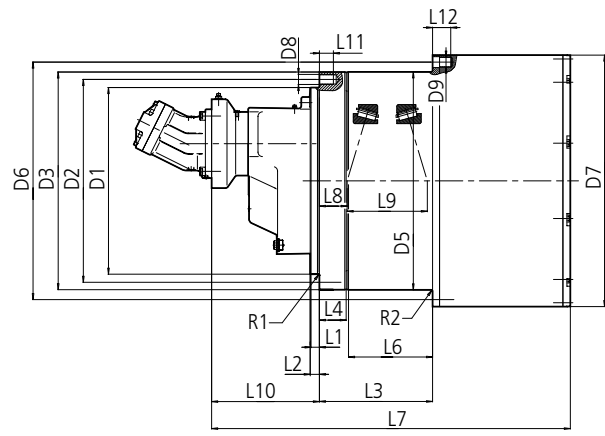

Crawler crane version - CC

Type		L1	L2	L3	L4	L5	L6	L7	L8	L9	L10	L11	L12	R1	R2	D1	D2	D3	D4	D5	D6	D7	D8	D9	Qty. D8/D9
F620	ST	50	57.5	245	52.5	53	75	1232	38	287	341	-	-	4	-	730	810	880	880	885	965	1020	M30x2	M30x2	41/48
	CC	30	33	405	96	-	306	1159	99	287	352.8	50	65	4	5	668	726	779	-	782	830	880	M36x1.5	M30x1.5	30/45
F650	CC	40	43	255	89	-	117	846.5	133	213	-	45	70	4	4	450	515	563	-	570	620	763	M36x1.5	M30x1.5	29/42
F700	CC	30	33	405	96	-	306	1283.5	99	287	352.8	50	65	4	5	668	726	779	-	780	850	900	M36x1.5	M36x1.5	30/45
F700A	CC	30	33	405	96	-	306	1372.5	99	287	474.8	50	65	4	5	668	726	779	-	780	850	900	M36x1.5	M36x1.5	30/45

\*Park brake integrated in hydraulic motor

1) Other ratios on demand

2) ST= Standard CC= Crawler Crane

3) Without hydraulic motor

# Travel drives

## Overall dimensions and technical data | F800 ... F1800

Type	Ratio <sup>1</sup>	Version <sup>2</sup>	Capacity of Bearing		Weight <sup>3</sup>	Park Brake		Hydraulic Motor	
			C-dynamic	Co-static		Locking torque	Release pressure min.	Plug-in fixed	Plug-in variable
	i		kN	kN	kg	Nm	bar	ccm	ccm
F800	283-298	ST	2,485	5,941	3,764	1,000*	7.8*	(2x) 250	(2x) 250-(2x) 280
F1100	406	ST	3,900	7,650	7,220	1,750	20	(2x) 250	(2x) 250-(2x) 280
F1300	461	ST	3,900	7,650	7,400	1,750	20	(2x) 250	-
F1800	656-744	ST	3,900	7,650	7,500	1,200	28	-	(2x) 250-(2x) 280
		CC	3,900	7,650	9,000	1,200	28	(2x) 250	(2x) 250-(2x) 280

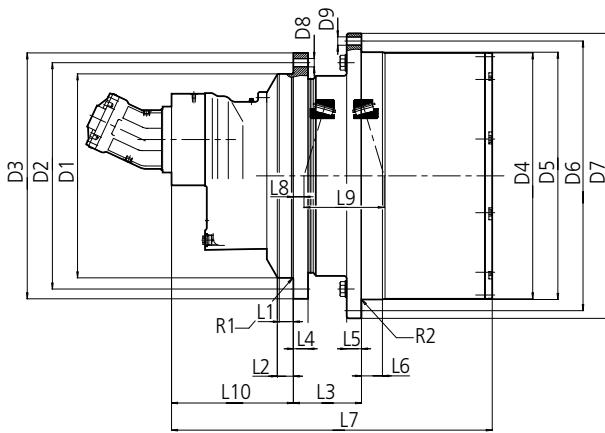

Standard input version - ST

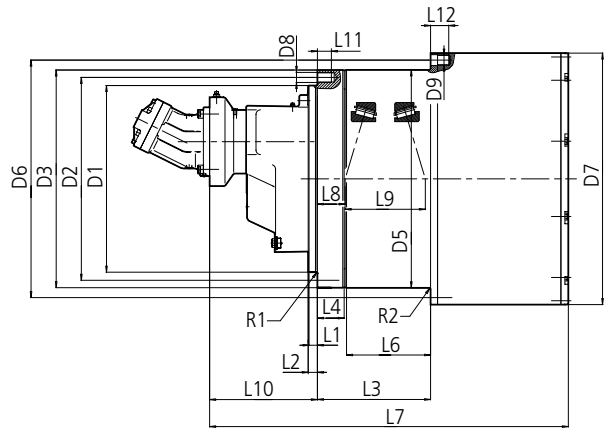

Crawler crane version - CC

Type		L1	L2	L3	L4	L5	L6	L7	L8	L9	L10	L11	L12	R1	R2	D1	D2	D3	D4	D5	D6	D7	D8	D9	Qty. D8/D9
F800	ST	20	25	229	60	58	170	1315	161/163	257/253	713	-	-	6	8	830	980	1050	916	920	976	1055	M30x2	M30x2	48/48
F1100	ST	57	60	503	74	-	-	1483	176	368	713	-	-	10	6	1110	1230	1310	1116	-	1170	1226	M36x4	M30x3.5	48/52
F1300	ST	57	60	503	74	-	-	1623	176	368	395.5	-	-	10	6	1110	1230	1310	1116	1100	1170	1226	M36x4	M30x3.5	48/52
F1800	ST	54	60	310	74	107	191.5	1839.5	176	368	615.5	-	-	10	10	1110	1230	1310	1224	1250	1350	1430	M36x1.5	M42x2	48/40
	CC	55	60	478	158	-	239	1785.5	171	375	602.5	50	90	4	6	785	851	923	-	935	1016	1224	M42x2	M42x2	40/40

\* Park brake integrated in hydraulic motor

1) Other ratios on demand

2) ST= Standard CC= Crawler Crane

3) Without hydraulic motor

## Overall dimensions and technical data | F2000 ... F3000

Type	Ratio <sup>1</sup>	Version <sup>2</sup>	Capacity of Bearing		Weight <sup>3</sup>	Park Brake		Hydraulic Motor	
			C-dynamic	Co-static		Locking torque	Release pressure min.	Plug-in fixed	Plug-in variable
	i		kN	kN	kg	Nm	bar	ccm	ccm
F2000	516 - 989	ST	5,100	11,600	10,700	2,300	22	-	(2x) 250 - (2x) 355
		CC	3,900	7,650	9,000	1,200	28	-	(2x) 355
F2200	552-989	ST	5,100	11,600	10,736	2,300	22	(2x) 355	(2x) 355
		CC	3,900	7,650	9,000	1,200	28	(2x) 250	(2x) 250-(2x) 280
F3000	699	ST	6,110	11,900	11,500	1,700	12	-	(2x) 250-(2x) 280

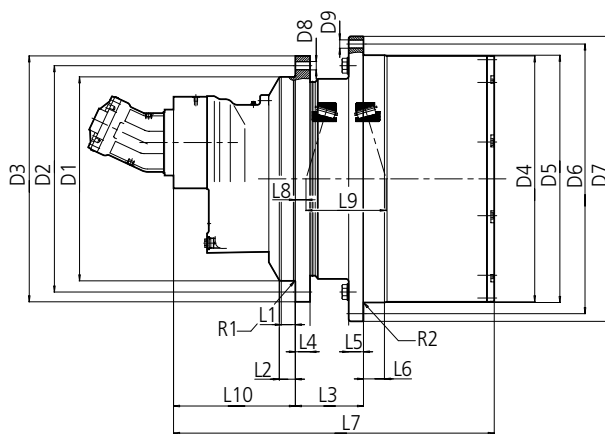

Standard input version - ST

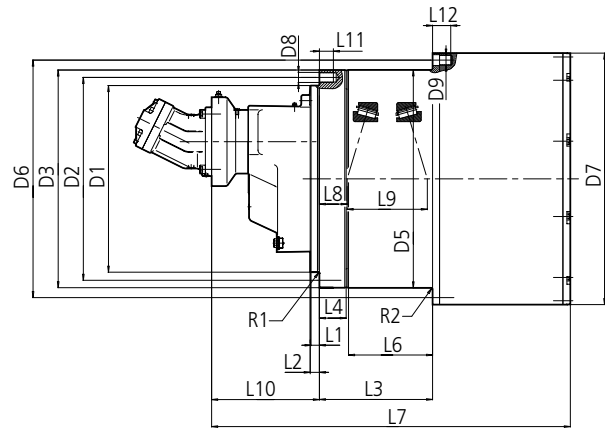

Crawler crane version - CC

Type		L1	L2	L3	L4	L5	L6	L7	L8	L9	L10	L11	L12	R1	R2	D1	D2	D3	D4	D5	D6	D7	D8	D9	Qty. D8/D9
F2000	ST	70	70	343	80	100	80	1846	217	376	591	-	-	10	10	1288	1400	1500	1224	1230	1320	1400	M42x3	M42x3	50/48
	CC	60	60	478	159	-	239	1956,5	171	375	626	-	-	4	6	785	858	930	1224	935	1016	1224	M48x2	M48x2	36/36
F2200	ST	60	70	343	80	100	80	1846	217	376	591	-	-	10	10	1288	1400	1500	1224	1230	1320	1400	M42x3	M42x3	50/48
	CC	55	60	478	158	-	239	1956,5	171	375	626	55	93	4	6	785	858	930	-	935	1016	1224	M48x2	M48x2	36/36
F3000	ST	60	70	343	80	100	80	2000	217	376	606	-	-	10	10	1288	1400	1500	1224	1230	1320	1400	M42x3	M42x3	50/48

\* Park brake integrated in hydraulic motor  
 1) Other ratios on demand

2) ST= Standard CC= Crawler Crane  
 3) Without hydraulic motor

# Travel drives



## FP Series

### Final drives angular input

The FP Series are perfectly suitable with any crawler, large excavators and crushers. Thanks to compact, rugged design, high torque and load capabilities, these solutions are the best possible option for the machine. All units are available with a fail-safe parking brake. Different disengagement systems are available on demand for all the sizes.



HYDRAULIC SOLUTIONS

### Gear ratios

- 248 ... 825

### Standard features

- Compact structure
- High performance
- 3-7 Planetary wheels per stage
- Notchless ground tooth root
- Different ratios
- Integrated disc-brake

### Special executions on request

- Mechanical disconnect device
- Low and high temperature version

### Torque (kNm)

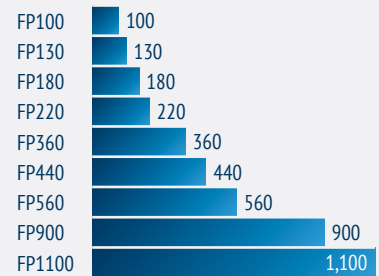

*Stated torques are peak values for short duration.*



## Overall dimensions and technical data

Type	Ratio <sup>1</sup>	Version <sup>2</sup>	Capacity of Bearing		Weight	Park Brake Optional	
			C-dynamic	Co-static		Locking torque <sup>3</sup>	Release pressure min.
	i		kN	kN	kg	Nm	bar
FP100	426	ST	498	1,010	410	600	15
FP130	825	ST	523	980	452	750	19
FP180	412	ST	787	1,650	757	1,375	35
FP220	248	ST	765	1,660	915	1,200	15
FP360	446	ST	1,040	2,450	1,065	1,700	12
FP440	528	CC	1,040	2,450	1,300	1,700	15
FP560	450	CC	1,040	2,450	2,222	900	13
FP900	406	CC	2,800	6,390	3,750	-	-
FP1100	1,088	ST	3,900	7,650	7,684	-	-

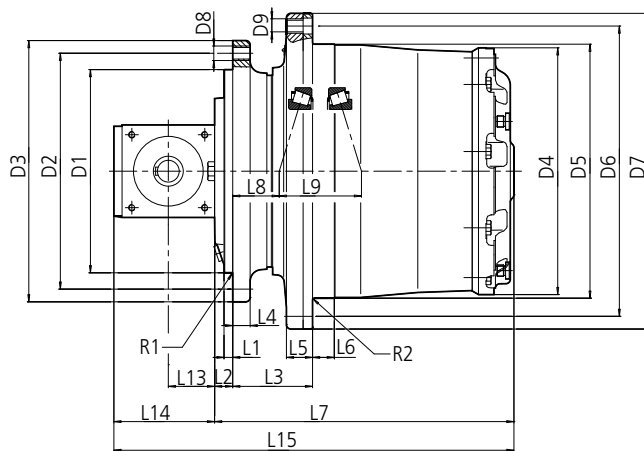

Standard input version - ST

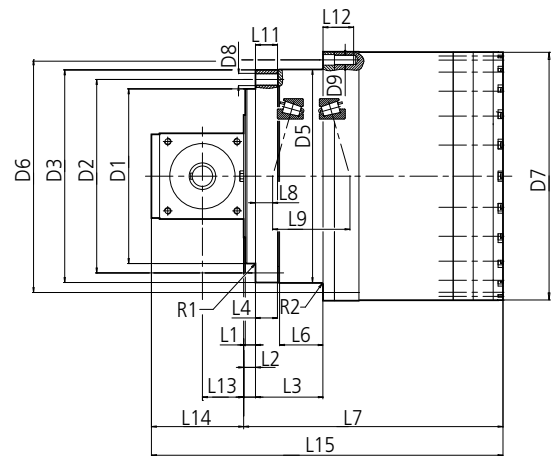

Crawler crane version - CC

Type	L1	L2	L3	L4	L5	L6	L7	L8	L9	L10	L11	L12	L13 <sup>4</sup>	L14 <sup>4</sup>	L15 <sup>4</sup>	L16 <sup>4</sup>	L17 <sup>4</sup>	R1	R2	D1	D2	D3	D4	D5	D6	D7	D8	D9	Qty. D8/D9	D10 <sup>4</sup>	D10 Key <sup>4</sup>
FP100	35	65	165	28	53	43	463	32	139	-	-	-	115	215	678	60	215	12/60	5	390	460	500	407	408	460	500	M24x2	M24x2	30/24	40	DIN6885 (A12x8x50)
FP130	45	45	190	35	58	45	530	50.5	147	-	-	-	311	411	941	60	215	25	4	390	500	550	449	450	500	550	M24x2	M24x2	32/32	40	DIN6885 (A14x9x70)
FP180	30	30	168	40	56	21.5	534.5	50.3	141.4	-	-	-	437.5	542.5	1077	75	265	4	3	450	510	560	528	535	600	650	M24x2	M27x2	20/30	50	DIN6885 (A16x10x80)
FP220	18	52	166.5	40	61	35	580.5	16	187.5	-	-	-	448	593	1173.5	85	300	35°/16/16	4	460	600	650	540	542	600	650	M24x2	M24x2	38/38	55	DIN6885 (A18x11x100)
FP360	100	100	130	40	60	60	657.5	25	215	-	-	-	380	545	1202.5	110	387	18°/100/16	10	580	680	735	649.5	650	720	775	M30x3.5	M30x3.5	30/30	60	DIN6885 (A18x11x100)
FP440	40	43	255	40	-	120	814	80	213	-	40	70	255	400	1214	85	300	4	4	450	515	569	-	570	620	670	M36x1.5	M30x2	29/42	55	DIN6885 (A16x10x80)
FP560	40	43	255	45	-	120	831.5	80	213	-	45	70	857	1104	1935.5	160	570	4	4	450	515	569	-	570	620	763	M36x1.5	M30x1.5	29/42	90	DIN6885 (A25x14x150)
FP900	30	33	405	96	-	306	965	129	258.5	-	50	68	612	859	1824	120	540	4	5	668	726	779	-	780	850	900	M36x1.5	M36x1.5	30/45	75	DIN6885 (A18x11x100)
FP1100	54	60	503	74	-	326	1429	179	368	-	-	-	-	-	-	-	-	4	5	1110	1230	1310	1116	1100	1170	1226	M36	M30	48/52	60	DIN6885 (A18x11x100)

1) Other ratios on demand

2) ST= Standard CC= Crawler Crane

3) Optional brake torques

4) Other dimensions optional

## Travel drives



### Planetary gearbox with integrated kit motor

The F Series is perfectly suited to any crawler and milling machine. Thanks to compact, rugged design, high torque and load capabilities, these solutions are the best possible option for these machines. All units are available with a fail-safe parking brake and for most cartridge type fixed or variable systems. Different disengagement systems are available on demand for all the sizes.



HYDRAULIC SOLUTIONS

#### Gear ratios

- 45.2

#### Features

- Integrated hydraulic motor
- 2 – Stage planetary drive
- 2 – Speed hydraulic motor
- Counterbalance travel valve
- High pressure relief valves
- 2 – Speed shift function by external pilot control
- Automatically release park brake

#### Torque (kNm)

F30K	under development
F45K	45
F55K	under development
F80K	under development
F100K	under development

## Overall dimensions and technical data

Type	Ratio	Capacity of Bearing		Weight	Park Brake		Hydraulic Motor			
		C-dynamic	Co-static		Locking torque	Automatic release	Variable displacement	Max. pressure	Max. pump flow	Pilot pressure
	i	kN	kN	kg	Nm		ccm	bar	L/min	bar
F45K	45.2	215	291	296	400	-	175 max / 99 min	350	240	10-40

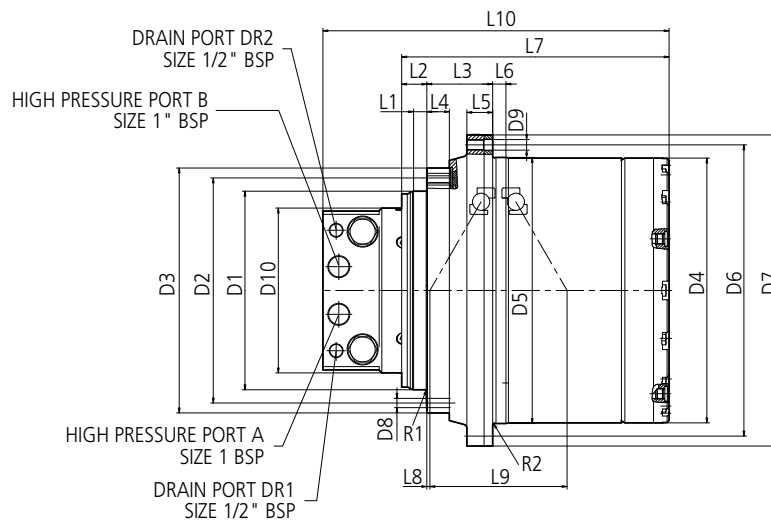

Type	L1	L2	L3	L4	L5	L6	L7	L8	L9	L10	R1	R2	D1	D2	D3	D4	D5	D6	D7	D8	D9	Qty. D8/D9	D10
F45K	20	34	98.5	34	39	20	404	6	213	523	1	2.5	300	340	370	400	402	440	370	M16x2	M16x2	30/30	249

**Note:** size of high pressure ports A and B optionally PF1" or SAE 1"

# Travel drives



## F Series Final Drives 2 - Speed

The F Series is perfectly suited to any crawler and milling machine. Thanks to compact, rugged design, high torque and load capabilities, these solutions are the best possible option for these machines. All units are available with a fail-safe parking brake and for most cartridge type fixed or variable systems. Different disengagement systems are available on demand for all the sizes.



HYDRAULIC SOLUTIONS

### Output torque max.

- 40000 Nm

### Input speed max.

- 3500 rpm

### Applicable hydraulic motors

- Bosch-Rexroth: A6VE55 ~ 107 range
- Linde: HMV 55 ~ 75 range
- Sauer danfoss: 51C 060 ~ 080 range

### Technical features

- Two gear shifting transmission
- Wet disc clutch unit
- Power shift capability
- Hydraulic controlled shifting
- Integrated park & emergency brake
- Optional cooling flow to input stage and clutch unit
- Different hydraulic motors
- Wide variety of ratio combinations

### Ratio combinations

Shifting stage versions	Shifting stage ratio ISS
1	5.77
2	5.42
3	4.87*
4	4.44
5	4.26
6	3.81

Main stage versions	Shifting stage ratio IMS
A	19.25
B	26*
C	32.14

All ratios ISS combinable with all ratios IMS

Final ratio if = ISS\*IMS

\* Preferred ratios

Brake torque at input shaft	Nm	600
Brake torque at output min.	Nm	40,000
Clutch operating pressure	bar	40 - 60
Oil quantity	l	3.3
Weight	kg	186

## Overall dimensions and technical data

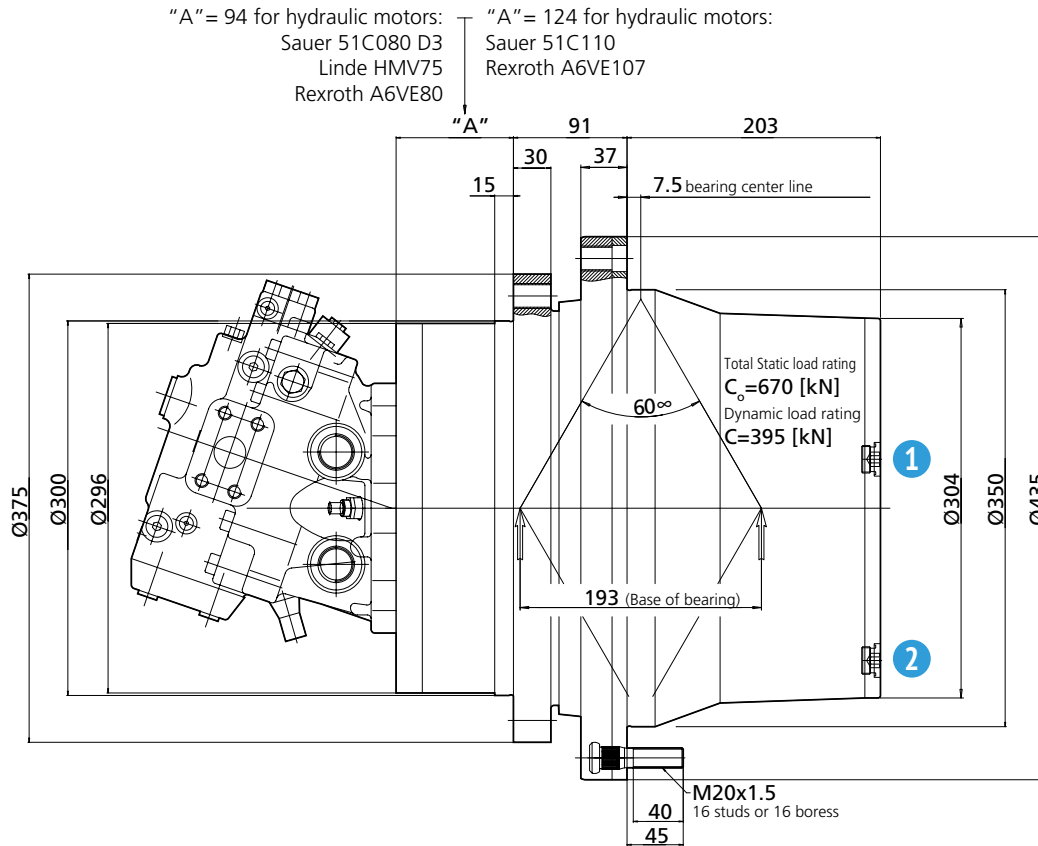

Hydraulic motor screw engagement depth 22

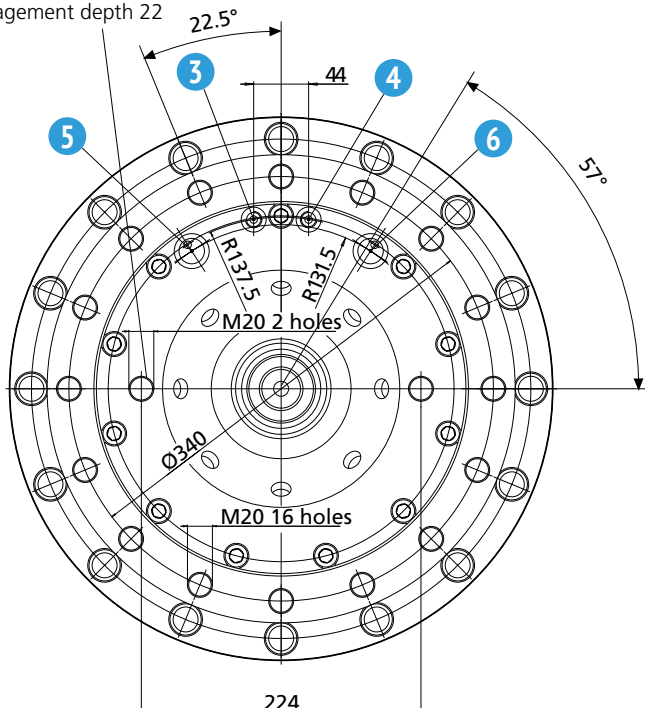

Port	Pressure	Function
3	40 bar	Small clutch piston pressurized T/M ratio lowgear
4	40 bar	Large clutch piston pressurized T/M ratio highgear
3 & 4	0 bar	Large & small clutch engaged, T/M in park break position

1. Oil filling plug M22×1.5
2. Oil draining plug M22×1.5
3. Low speed clutch port R1/4"G acc. DIN3852 "X"
4. High speed clutch port R1/4"G acc. DIN3852 "X"
5. Flushing oil input port M22×1.5 DIN3852 "X"
6. Flushing oil output port M22×1.5 DIN3852 "X"

# Travel drives



## FR Series Wheel Drives

The FR Series is the best solution when designing large wheeled off-road machinery. With a compact design, high torque and load capacities, a negative multi-disk parking brake and an optional disengagement device to tow the vehicle in an emergency, these solutions precisely match the application requirements.



HYDRAULIC SOLUTIONS

### Gear ratios

- 28 ... 34

### Standard features

- Compact structure
- High performance
- 3-7 Planetary wheels per stage
- Notchless ground tooth root
- Different ratios
- Integrated disc-brake

### Special executions on request

- Mechanical disconnect device

### Max. torque (kNm)



### Nominal torque (kNm)



*Stated torques are peak values for short duration.*

## Overall dimensions and technical data

Type	Ratio <sup>1</sup>	Version	Capacity of Bearing		Weight <sup>3</sup>	Input torque max.	Hydraulic Motor <sup>2</sup> (Variable)	Operating pressure max.	Service brake <sup>4</sup>			Park Brake <sup>4</sup>	
			C-dynamic	Co-static					Pressure max.	Locking torque dyn.	Locking torque max.stat.	Release pressure max.	Release pressure max.
	i		kN	kN	kg	Nm	ccm	bar	bar	Nm	Nm	bar	bar
FR20	28-34	A	194	325	129	560	80 (105)	420	100	9,500	24,480	80	40
FR40	30-32	B	300	560	173	715	107 (-)	420	110	13,000	23,000	80	40
FR60	29-34	A	352	735	500	1,066	160 (-)	420	90	28,000	30,000	60	25

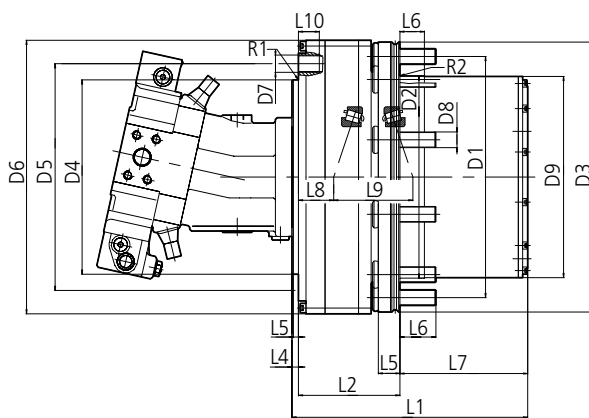

Version A

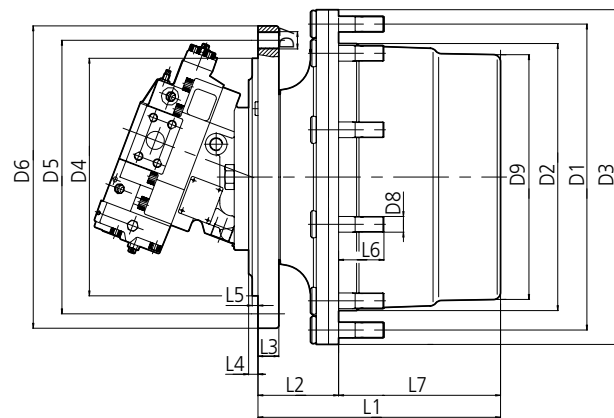

Version B

Type	L1	L2	L3	L4	L5	L6	L7	L8	L9	L10	R1	R2	D1	D2	D3	D4	D5	D6	D7	D8	D9
FR20	318	141	-	9	7	50	177.5	58	110	29	-	-	335	280.8 f7	375	270 f8	315	380	10xM24x2	10xM22x1.5	279.5
FR40	441	135.7	52.7	80	43	63	225	80	105	32	5	1	425	371-0.2	465	290 f8	367	405	M24(6x) M20(4x)	18xM22x1.5	340
FR60	520	270	-	10	7	60	240	156	173	37	-	1.6	425	375 f8	559	290 f8	330	554	10xM24x2	24xM22x1.5	356

1) Other ratios on demand  
2) Other hydraulic motors on request

3) Without hydraulic motor  
4) Multi-disk brake

# Slew drives



## S Series

The Bonfiglioli S series provides the safest and most effective solution for cranes, excavators and forestry machines. Its compact design allows it to perfectly fit cranes, excavators and special equipment where installation space is limited.



HYDRAULIC SOLUTIONS

### Gear ratios

- 23 ... 67

### Standard features

- Compact structure
- High performance
- Notchless ground tooth root
- Integrated disc-brake
- Suitable for various hydraulic motors

### Torque (kNm)

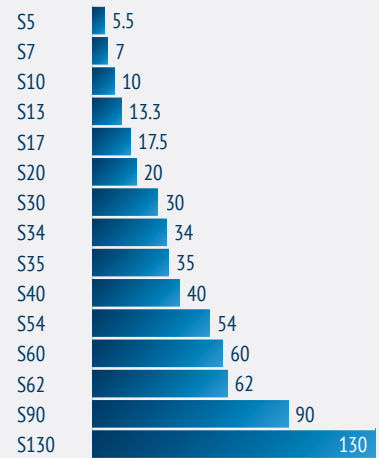

*Stated torques are peak values for short duration.*



## Overall dimensions and technical data | S5 ... S17

Type	Ratio <sup>1</sup>	Hydraulic motors <sup>2</sup>	Multi-disc brake		Output pinion <sup>3</sup>							Weight without Motor (appr.) kg
			Braking torque Nm	Release pressure min. bar	z/m - B - D5							
S5	25-33	28-30-32	310	14	10/10	10/10	11/10	14/8	15/6,35	-	-	68
					95	79	79	69	77	-		
					130	130	143	134	112	-		
S7	23-27-33	45-56-63	475	14	10/11	12/10	13/10	13/10	-	-	-	98
					79	79	79	98	-	-		
					141	151	158	155	-	-		
S10	24-27-31-36	45-56-63-80-90	475	14	12/12	13/10	13/10	13/10	13/12	13/12	-	108-123
					90	85	94.5	100	110	90		
					184	158	155	158	190	195		
S13	36	56-63-80-90	740	18	10/14	11/14	12/12	13/12	13/12 <sup>4</sup>	14/12	14/12	147
					99	99	99	88	110 <sup>4</sup>	110		
					181	198	184	195	190 <sup>4</sup>	199	201	
S17	33	80-90	890	18	11/14	11/16	12/12	13/12 <sup>4</sup>	13/14	14/16	-	168
					109	109	104	110 <sup>4</sup>	122	150		
					198	220	184	190 <sup>4</sup>	221	273		

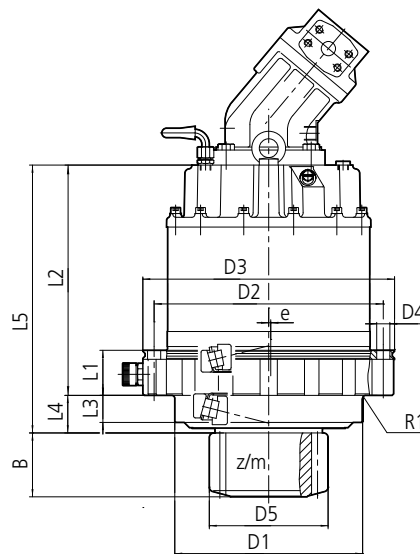

Type	L1	L2	L3	L4	L5	D1	D2	D3	D4	e	R1
S5	60	262	31	40	302	175	260	288	12x17.5	-	6
S7	60	296	31	40.5	336.5	230	285	322	12x17.5	-	6
S10	60	306.5-314	36	50	356.5-364	250	305	335	18x17.5	-	4
S13	71	340	30(50) <sup>4</sup>	55(75) <sup>4</sup>	395(415) <sup>4</sup>	275	335	370	20x17.5	1	4
S17	86	355	50.5	55	410	275	335	370	20x17.5	-	4

1) Other ratios on demand  
2) Other hydraulic motors on request

3) Output Pinion execution acc. to requirement  
4) Optional

# Slew drives

## Overall dimensions and technical data | S20 ... S40

Type	Ratio <sup>1</sup>	Hydraulic motors <sup>2</sup>	Multi-disc brake		Output pinion <sup>3</sup>						Weight without Motor (appr.)	
			Braking torque	Release pressure min.	z/m - B - D5							
	i	ccw	Nm	bar							kg	
S20	103-79	45	553	18	13/16 120 249	-	-	-	-	-	-	260
S30	45	125	1,030	18	12/16 154 243	-	-	-	-	-	-	540
S34	45	160	1,030	18	12/16 154 243	-	-	-	-	-	-	480
S35	35	180	1,030	18	12/18 160 274	-	-	-	-	-	-	528
S40	62	90	574	18	12/16 100 235	-	-	-	-	-	-	274

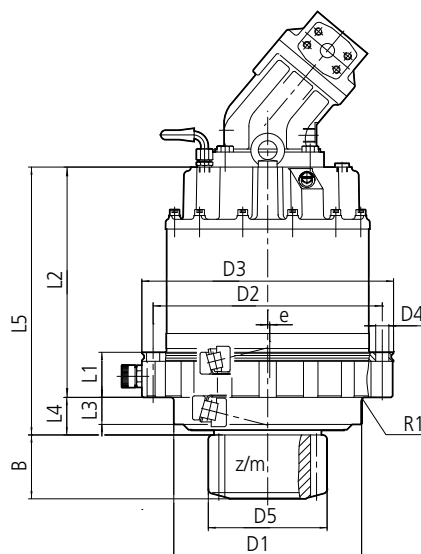

Type	L1	L2	L3	L4	L5	D1	D2	D3	D4	e	R1
S20	57	403	16	252	775	280	350	380	18	-	-
S30	332	737	33	65	802	350	415	450	24x22	-	1.6
S34	332	785	33	65	808	350	415	450	24x22	-	1.6
S35	239	653	<sup>30</sup>	91	744	400	460	500	24x26	2	10
S40	64	625	16	245	721	282	375	410	18	-	-

1) Other ratios on demand

2) Other hydraulic motors on request

3) Output Pinion execution acc. to requirement

## Overall dimensions and technical data | S54...S130

Type	Ratio <sup>1</sup>	Hydraulic motors <sup>2</sup>	Multi-disc brake		Output pinion <sup>3</sup>						Weight without Motor (appr.) kg	
			Braking torque Nm	Release pressure min. bar	z/m - B - D5							
S54	48	180-200	1,200	38	13/22 230 357	12/20 188 301	-	-	-	-	-	867
S60	62	80	1,200	38	13/22 228 356	-	-	-	-	-	-	
S62	187	80	533	18	14/20 160 335	-	-	-	-	-	-	564
S90	39	355-200	3,000	14	16/24 182 464	16/22 177 422	-	-	-	-	-	1,225
S130	67	Electric <sup>4</sup>	2,300	22.5	13/30 230 480	-	-	-	-	-	-	2,276

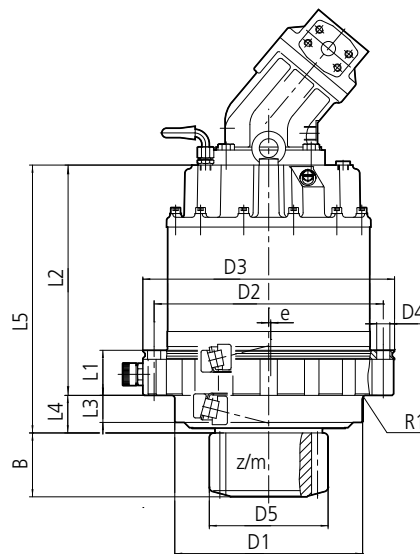

Type	L1	L2	L3	L4	L5	D1	D2	D3	D4	e	R1
S54	610	780	40	87	917	460	520	562	24x26	-	-
S60	-	830	40	132	962	460	520	562	26	-	-
S62	60	735	20	28	763	-	-	-	-	-	-
S90	80	730	<sup>175</sup>	199	929	500	640	690	18x30	-	-
S130	578	622	95	160	1012	630	675	715	34x26	-	-

1) Other ratios on demand  
2) Other hydraulic motors on request

3) Output Pinion execution acc. to requirement  
4) Hydraulic motor connection on demand

# Cutter drives



## FA Series Medium cutter drives

Dual stage planetary drive units with integrated pulley support, designed for cold planers, milling machines and surface mining machines with engine power from 80 to 1200kW and different rotor widths. The offset input option ensures higher machine productivity due to the increased cutting depth. The shifttable 2 speed solution allows two possible cutting speeds with huge benefits in terms of machine performance.



HYDRAULIC SOLUTIONS

### Gear ratios

- 16 ... 26

### Standard features

- Compact structure
- High performance
- Notchless ground tooth root
- Different ratios
- Integrated disc-brake
- Suitable for various hydraulic motors

### Cutting torque (kNm)

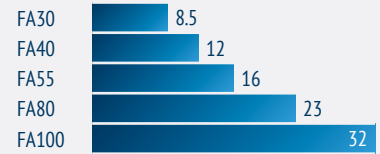

### Input power (kW)



## Overall dimensions and technical data

Type	Ratio <sup>1</sup>	Version <sup>2</sup>	Capacity of Bearing		Weight
			C-dynamic	Co-static	
			kN	kN	
	i				kg
FA30	19-22	ST	132/194	255/325	86
FA40	19	ST	224	405	122
		MI	224	405	172
FA55	16-19-22	ST	224	405	163
		MI	224	405	223
FA80	19	ST	300	570	223
FA100	14-21-22-26	ST	498	1,010	330
		MI	498	1,010	360

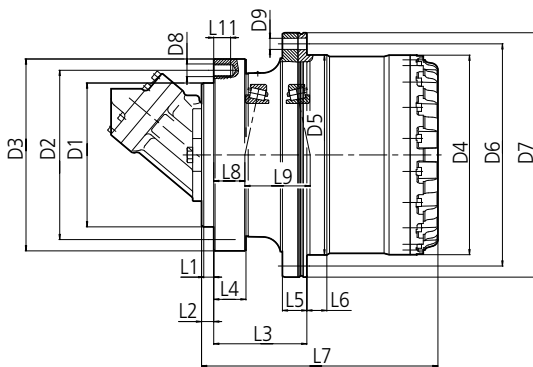

Standard input version - ST

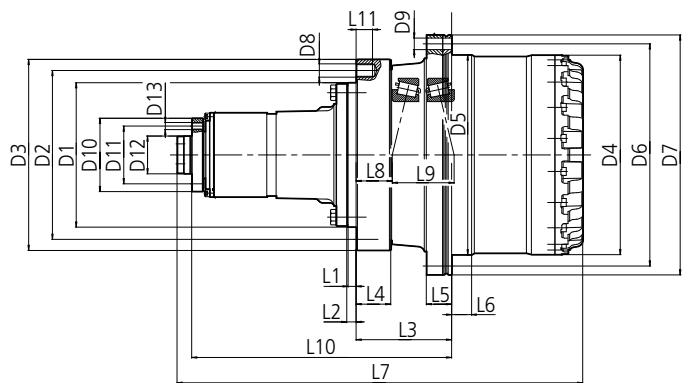

Mechanical input version - MI

Type		L1	L2	L3	L4	L5	L6	L7	L8	L9	L10	L11	R1	R2	D1	D2	D3	D4	D5	D6	D7	D8	D9	Qty. D8/D9	D10	D11	D12	D13	Qty. D13
FA30	ST	13	25	75	15	29	25	278.5	28	89	-	15	2.5	2.5	-	-	-	269	270	305	335	M16x2	17.5	18/18	-	-	-	-	-
FA40	ST	12	35	91	21	34	26	327	38	100	-	21	2.5	2.5	270	310	345	294	295	335	370	M20x1.5	17.5	16/20	-	-	-	-	-
	MI	10	10	125	55	32	26	631.5	72	100	402	55	1	2.5	270	310	360	294	295	335	370	M20x1.5	17.5	16/20	138	110	80	M16x2	6
FA55	ST	12	25	110	24	34	30	374	64	113	-	24	1	2.5	280	325	360	329	350	400	435	M20x1.5	22	24/20	-	-	-	-	-
	MI	18	18	136	50	34	30	688.5	90	113	421	50	1	2.5	280	325	360	329	350	400	435	M20x1.5	22	24/20	138	110	80	M16x2	6
FA80	ST	20	35	90	22	35	24	414.5	34	123	-	22	4	2.5	330	370	410	374	400	450	490	M24x2	25	20/20	-	-	-	-	-
FA100	ST	35	35	165	28	51	43	461	32	139	-	28	12/60	5	390	460	500	407	408	460	502	M24x2	26	30/24	-	-	-	-	-
	MI	8	8	182	28	40	43	843.5	27	138	540	28	1.6	2.5	325	380	415	407	408	460	502	M20x2.5	26	12/12	165	130	85	M16x2	8

1) Other ratios on demand

2) ST - Standard Input / MI - Mechanical Input (Hydraulic Motor)

# Cutter drives



## FA Series

### Large cutter drives

Dual stage planetary drive units with integrated pulley support, designed for cold planers, milling machines and surface mining machines with engine power from 80 to 1200kW and different rotor widths. The offset input option ensures higher machine productivity due to the increased cutting depth. The shiftable 2 speed solution allows two possible cutting speeds with huge benefits in terms of machine performance.



HYDRAULIC SOLUTIONS

### Gear ratios

- 14 ... 26

### Standard features

- Compact structure
- High performance
- Notchless ground tooth root
- Different ratios
- Integrated disc-brake
- Suitable for various hydraulic motors

### Cutting torque (kNm)

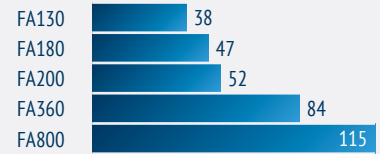

### Input power (kW)



## Overall dimensions and technical data

Type	Ratio <sup>1</sup>	Version <sup>2</sup>	Capacity of Bearing		Weight
			C-dynamic	Co-static	
	i		kN	kN	kg
FA130	14-18-21-22-26	ST	750	1,290	426
		MI	750	1,290	490
FA180	23	MI	755	1,339	637
FA200	20-24	ST	787	1,650	710
		MI	787	1,650	718
FA360	25	ST	1,040	2,450	1,145
FA800	24	ST	4,300	9,650	4,223

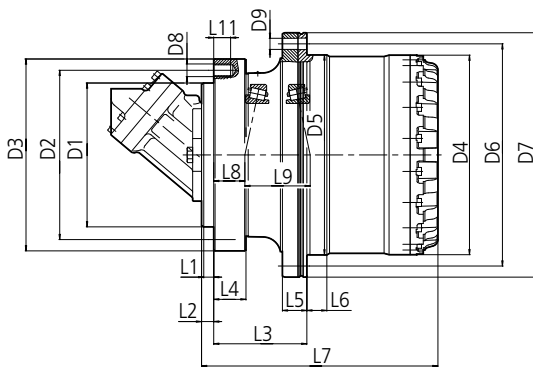

Standard input version - ST

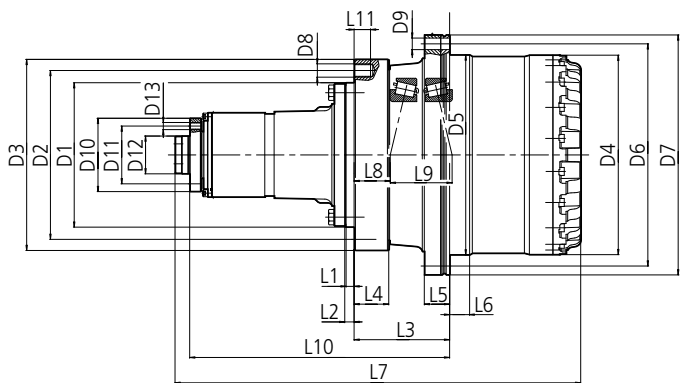

Mechanical input version - MI

Type		L1	L2	L3	L4	L5	L6	L7	L8	L9	L10	L11	R1	R2	D1	D2	D3	D4	D5	D6	D7	D8	D9	Qty. D8/D9	D10	D11	D12	D13	Qty. D13
FA30	ST	18	20	215	78	57	45	530	81.4	139.2	-	37	2	2	325	380	430	449	450	500	540	M30x3.5	26	12/24	-	-	-	-	-
	MI	18	20	215	78	57	45	913	81.4	139.2	585	37	2	2	325	380	430	449	450	500	540	M30x3.5	26	12/24	165	130	85 <sup>1/6</sup>	M16x2	8
FA40	MI	20	20	173.5	80	56	21.5	913	81	140	576	30	2	2	325	380	-	528	529	565	-	M30	M16	12/30	-	-	-	-	-
FA55	ST	20	25	160	102	58	22	603.5	75.8	149.4	-	37	2	2	323.8	381	482	540	605	635	663	M30x2	18	12/24	-	-	-	-	-
	MI	20	25	160	102	58	22	890.5	75.8	149.4	438	37	2	2	323.8	381	482	540	605	635	663	M30x2	18	12/24	165	130	85 <sup>1/6</sup>	M16x2	8
FA80	ST	35	100	130	40	60	80.5	657.5	75.1	214.8	-	40	18°/100/16	10	580	680	735	649.5	650	720	775	M30x3.5	M30x3.5	30/30	-	-	-	-	-
FA100	ST	20	25	229	60	95	89	981	( <sup>3</sup> )	( <sup>3</sup> )	-	60	6	8	830	980	1050	930	1040	1250	1329	M30x2	M30x2	48/48	-	-	-	-	-

1) Other ratios on demand

2) ST - Standard Input / MI - Mechanical Input (Hydraulic Motor)

3) Special bearing

# Cutter drives



## FA Series Cutter Drives 2-Speed

Dual stage planetary drive units with integrated pulley support, designed for cold planers, milling machines and surface mining machines with engine power from 80 to 1200kW and different rotor widths. The offset input option ensures higher machine productivity due to the increased cutting depth. The shiftable 2 speed solution allows two possible cutting speeds with huge benefits in terms of machine performance.



HYDRAULIC SOLUTIONS

### Gear ratios

- 13 ... 22

### Standard features

- Two speed shifting transmission
- Main drive from proven cutter standard range (FA130/FA200)
- Hydraulic shifting unit for gear change
- Cutter main drive & shifting unit modular concept for easy maintenance

### Cutting torque (kNm)

FA130-2S	38
FA200-2S	47

### Input power (kW)

FA130-2S	400
FA200-2S	540



## Overall dimensions and technical data

Type	Version	Ratio	Version	Capacity of Bearing		Weight	Shifting pressure	
				C-dynamic	Co-static		Min.	Max.
		i		kN	kN	kg	bar	bar
FA130 - 2S	1	21-13.67	ccw	750	1,290	900	35	50
	2	22.235-18.01						
FA200 - 2S	1	19.877-13	ccw	787	1,650	1,050	35	50
	2	21.05-17.05						

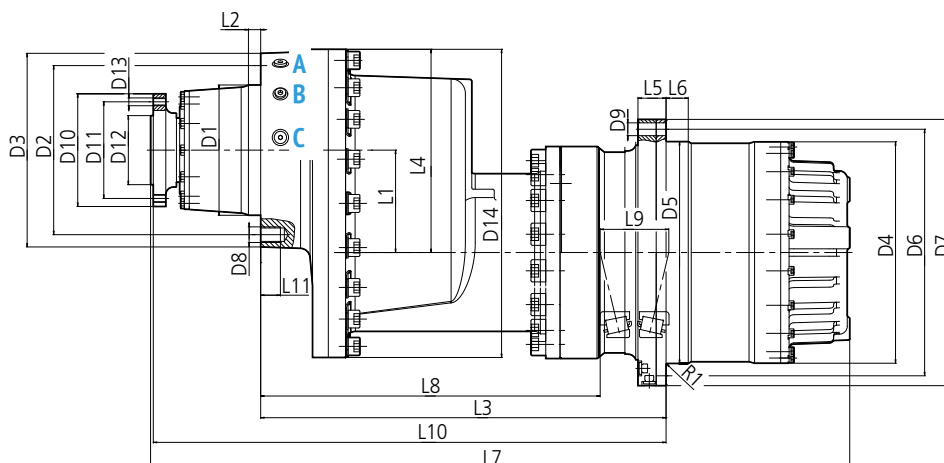

- A. Flushing port oil in
- B. Shifting port 50 bar
- C. Flushing port oil out

Type	L1	L2	L3	L4	L5	L6	L7 optional	L8	L9	L10	L11	R1	R2
FA130 - 2S	207.65	25	822.2	413	57	45	1418	1442.5	688.6	139.2	822.2	40	2
FA200 - 2S	207.65	25	807.2	413	32	25	1378	1402.5	683	149.4	1025	40	2

Type	D1	D2	D3	D4	D5	D6	D7	D8	Qty. D8	D9	Qty. D9	D10	D10 optional	D11	D11 optional	D12	D12 optional	D13	D13 optional	Qty. D13
FA130 - 2S	264.265	342.9	393	449	450	500	540	1.25-7 UNC	12	26	24	228.6	196.85	140	158.75	140	120.7	5/8-11 UNC	STUD 5/8-11 UNF	8
FA200 - 2S	264.265	342.9	393	533.5	590.8	641.35	679.32	1.25-7 UNC	12	19.84	20	228.6	196.85	140	158.75	140	120.7	5/8-11 UNC	STUD 5/8-11 UNF	8

# Winch drives

## Classification of crane

		Hoisting	Slewing	Boom Activation	Trolley Travelling	Crane Travelling
Erection cranes		M 2 - M 3	M 2 - M 3	M 1 - M 2	M 1 - M 2	M 2 - M 3
Loading bridges	hook	M 5 - M 6	M 4	–	M 4 - M 5	M 5 - M 6
Loading bridges	grab or magnet	M 7 - M 8	M 6	–	M 6 - M 7	M 7 - M 8
Workshop cranes		M 6	M 4	–	M 4	M 5
Overhead travelling cranes, ram cranes, scrap yard cranes	grab or magnet	M 8	M 6	–	M 6 - M 7	M 7 - M 8
Unloading bridges, container gantry cranes	hook or spreader	M 6 - M 7	M 5 - M 6	M 3 - M 4	M 6 - M 7	M 4 - M 5
Other gantry cranes (with trolley and/or live ring)	hook	M 4 - M 5	M 4 - M 5	–	M 4 - M 5	M 4 - M 5
Unloading bridges, container gantry cranes (with trolley and/or live ring)	grab or magnet	M 8	M 5 - M 6	M 3 - M 4	M 7 - M 8	M 4 - M 5
Berth cranes, shipyard cranes, dismantling cranes	hook	M 5 - M 6	M 4 - M 5	M 4 - M 5	M 4 - M 5	M 5 - M 6
Dockside cranes (slewing, gantry type, ...), floating cranes, floating sheerlegs	hook	M 6 - M 7	M 5 - M 6	M 5 - M 6	–	M 3 - M 4
Dockside cranes (slewing, gantry type, ...), floating cranes, floating sheerlegs	grab or magnet	M 7 - M 8	M 6 - M 7	M 6 - M 7	–	M 4 - M 5
Floating cranes and floating sheerlegs for very high loads (normally above 100 t)		M 3 - M 4	M 3 - M 4	M 3 - M 4	–	–
Shipboard cranes	hook	M 4	M 3 - M 4	M 3 - M 4	M 2	M 3
Shipboard cranes	grab or magnet	M 5 - M 6	M 3 - M 4	M 3 - M 4	M 4 - M 5	M 3 - M 4
Tower cranes for construction sites		M 4	M 5	M 4	M 3	M 3
Derrick tower gantry		M 2 - M 3	M 1 - M 2	M 1 - M 2	–	–
Railroad cranes, approved for service in trains		M 3 - M 4	M 2 - M 3	M 2 - M 3	–	–
Vehicle-mounted cranes	hook	M 3 - M 4	M 2 - M 3	M 2 - M 3	–	–

## Torque conversion factors **k** according to FEM 1.001 3<sup>rd</sup> edition, Section 1

	T2	T3	T4	T5	T6	T7	T8
Average usage per day [h]	0.25 - 0.5	0.5 - 1	1 - 2	2 - 4	4 - 8	8 - 16	about 16
Total service life [h]	400 - 800	800 - 1600	1600 - 3200	3200 - 6300	6300 - 12500	12500 - 25000	25000 - 50000

Duty cycle load class	Machine class & torque conversion factor K						
L1 light	M 1 1.24	M 2 1.24	M 3 1.11	M 4 1.11	M 5 0.95	M 6 0.91	M 7 0.85
L2 medium	M 2 1.24	M 3 1.24	M 4 1.08	M 5 1	M 6 0.87	M 7 0.80	M 8 0.67
L3 heavy	M 3 0.98	M 4 0.95	M 5 0.91	M 6 0.80	M 7 0.71	M 8 0.59	M 8 0.56
L4 extremely heavy	M 4 0.80	M 5 0.75	M 6 0.71	M 7 0.63	M 8 0.56	M 8 0.5	M 8 0.44

### Definition of Nominal Torque $T_{Nom}$

- Drum output speed 25 rpm
- FEM class M5 / T5 / L2

### Torque calculation $T_{eff}$ for alternative FEM – class

- $T_{eff} = K \times T_{Nom}$
- **K**: torque conversion factor

### Additional check - conditions

1. For all machine classes > M5 (M6-M8): to be checked, whether drum output speed 25rpm must be reduced. Refer to Bonfiglioli Sales or Application engineering.
2. Brake torque safety must be checked upon formula:

$$V = \frac{T_{Brake} \times i}{T_{eff}} > 1.6$$

$T_{Brake}$ : brake torque at drive input

i: drive ratio

If brake safety < 1.6 refer to Bonfiglioli Sales or Application engineering.

# Winch drives



## FW Series Small winch drives

The planetary winch gearboxes of the FW Series are suitable for a large spectrum of winch applications thanks to the availability of a wide torque range. The compact design allows the gearbox to be integrated into the winch drum. The failsafe brake can be integrated inside the gearbox or mounted externally, with common lubrication for the gears. Electrically driven versions are available with both in-line and right-angle configurations.



HYDRAULIC  
SOLUTIONS



ELECTRIC  
SOLUTIONS

### Gear ratios

- 35 ... 305

### Standard features

- Compact structure
- Robust layout of planetary gear unit
- Robust taper roller bearings for drum support and cable pull
- Integrated disc-brake
- Easy oil change from front side
- Easy drum mounting
- High variety of ratios and hydraulic motors

### Torque $T_{Nom}$ (kNm)

FW10	5.4
FW13	7.25
FW30	17.6
FW40	20
FW40A	20

## Overall dimensions and technical data

Type	Ratio <sup>1</sup>	Capacity of bearing		Weight <sup>2</sup>	Multi-disc brake			Hydraulic motor	
		C-dynamic	Co-static		Locking torque version <sup>3</sup>	Release pressure min.	Brake features <sup>4</sup>	Plug-in fixed	Plug-in variable
	i	kN	kN	kg	Nm	bar	-	ccm	ccm
FW10	35-51	132	255	45	200	17	-	28-30-32	28-45
FW13	93-108-122-140-178-229	132	255	50	200	17	-	28-30-32	28-45
FW30	61-66-81-90-101-114-121-137-171-228-305	132/194	255/325	94	300/400	16/22	-	28-30-32-40-45-56-60-63	28-55-60
FW40	61-66-81-85-101-110-117-124-142-181	224	405	115	420	18	-	40-45-56-60	55-60
FW40A		224	405	123	420	18	-	80-90	80

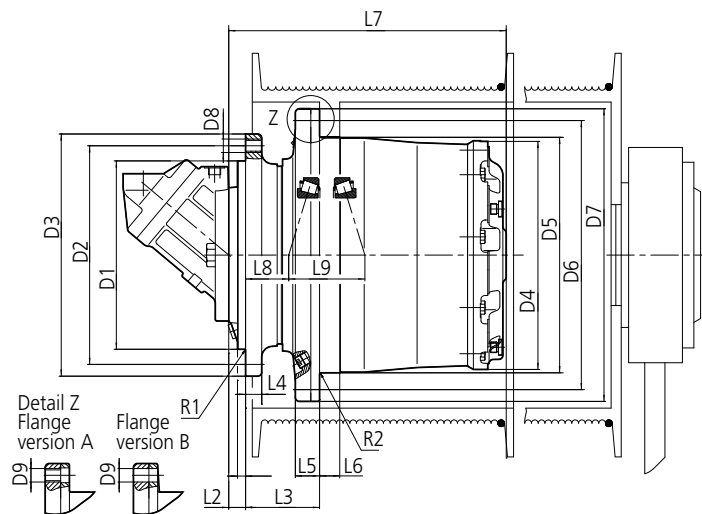

Type	L1	L2	L3	L4	L5	L6	L7	L8	L9	R1	R2	D1	D2	D3	D4	D5	D6	D7	D8	D9 Vers. A	D9 Vers. B	Qty. D8/D9
FW10	10	30	72	13.5	15	16	230	28	79	0.6	0.6	190	230	256	216	220	260	290	M16x2	M16x2	17	12/8
FW13	10	30	72	13.5	15	16	255	28	79	0.6	0.6	190	230	256	216	220	260	290	M16x2	M16x2	17	12/8
FW30	13	25/22	75	15	29	25	323/320	28.5	89	2.5	2.5	240	275	304	269	270	305	335	M16x2	M16x2	17	18/18
FW40	16	16	91	21	34	26	338	38	100	2.5	2.5	240	285	320	294	295	335	370	M16x1.5	M16x1.5	17.5	20/20
FW40A	13	35	91	21	34	26	357	38	100	2.5	2.5	270	310	345	294	295	335	370	M16x1.5	M16x1.5	17.5	16/20

1) Other ratios on demand  
2) Without Hydraulic motor

3) Optional brake torques on demand  
4) Option: external brake

# Winch drives



## FW Series Medium winch drives

The planetary winch gearboxes of the FW Series are suitable for a large spectrum of winch applications thanks to the availability of a wide torque range. The compact design allows the gearbox to be integrated into the winch drum. The failsafe brake can be integrated inside the gearbox or mounted externally, with common lubrication for the gears. Electrically driven versions are available with both in-line and right-angle configurations.



HYDRAULIC  
SOLUTIONS



ELECTRIC  
SOLUTIONS

### Gear ratios

- 61 ... 226

### Standard features

- Compact structure
- Robust layout of planetary gear unit
- Robust taper roller bearings for drum support and cable pull
- Integrated disc-brake
- Easy oil change from front side
- Easy drum mounting
- High variety of ratios and hydraulic motors

### Torque $T_{Nom}$ (kNm)

FW55	25.4
FW55A	25.4
FW55B	25.4
FW80	42.8
FW100	70

## Overall dimensions and technical data

Type	Ratio <sup>1</sup>	Capacity of bearing		Weight <sup>2</sup>	Multi-disc brake			Hydraulic motor	
		C-dynamic	Co-static		Locking torque version <sup>3</sup>	Release pressure min.	Brake features <sup>4</sup>	Plug-in fixed	Plug-in variable
	i	kN	kN	kg	Nm	bar	-	ccm	ccm
FW55		224	405	165	420/500	15/21	-	80-90	80
FW55A	63-68-87-94-117-124-137-148-185	224	405	177	420/500	15/21	-	40-45-56-60	55-60
FW55B		224	405	181	420/500	15/21	-	-	107-110
FW80	61-81-101-114-121-137-147-171-187-206	300	570	255	600/1,000	18/28	-	80-90-107-110-160-180	80-107-110-160
FW100	77-84-95-121-142-175-192-226	498	1,010	330	600/1,500	15/41	-	107-125-160-180	107-110-160

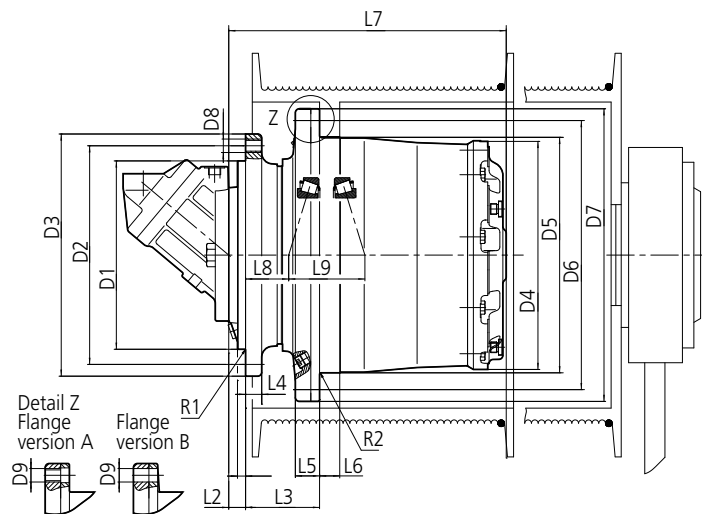

Type	L1	L2	L3	L4	L5	L6	L7	L8	L9	R1	R2	D1	D2	D3	D4	D5	D6	D7	D8	D9 Vers. A	D9 Vers. B	Qty. D8/D9
FW55	12	25	110	24	36	30	413	64	113	1	2.5	280	325	360	340	350	400	435	M20x1.5	M20x1.5	22	24/20
FW55A	20	30	91	24	36	30	399	45	113	4	2.5	240	285	320	340	350	400	435	M20x1.5	M20x1.5	22	20/20
FW55B	12	37	110	24	36	30	425	64	113	1	2.5	290	335	370	340	350	400	435	M20x1.5	M20x1.5	22	20/20
FW80	20	35	90	22	37	24	415	34	123	4	2.5	330	370	410	374	400	450	490	M24x2	M24x2	26	20/20
FW100	35/37	35/37	165	28	53	43	461/463	32	139	10 (12)/60	5	390	460	500	407	408	460	500	M24x2	M24x2	26	30/24

1) Other ratios on demand  
2) Without Hydraulic motor

3) Optional brake torques on demand  
4) Option: external brake

# Winch drives



## FW Series

### Large winch drives

The planetary winch gearboxes of the FW Series are suitable for a large spectrum of winch applications thanks to the availability of a wide torque range. The compact design allows the gearbox to be integrated into the winch drum. The failsafe brake can be integrated inside the gearbox or mounted externally, with common lubrication for the gears. Electrically driven versions are available with both in-line and right-angle configurations.



HYDRAULIC  
SOLUTIONS



ELECTRIC  
SOLUTIONS

### Gear ratios

- 24 ... 490

### Standard features

- Compact structure
- Robust layout of planetary gear unit
- Robust taper roller bearings for drum support and cable pull
- Integrated disc-brake
- Easy oil change from front side
- Easy drum mounting
- High variety of ratios and hydraulic motors

### Torque $T_{Nom}$ (kNm)

FW130	100
FW180	112.5
FW220	140
FW260	175
FW360	210



## Overall dimensions and technical data

Type	Ratio <sup>1</sup>	Capacity of bearing		Weight <sup>2</sup>	Multi-disc brake			Hydraulic motor	
		C-dynamic	Co-static		Locking torque version <sup>3</sup>	Release pressure min.	Brake features <sup>4</sup>	Plug-in fixed	Plug-in variable
	i	kN	kN	kg	Nm	bar	-	ccm	ccm
FW130	81-85-115-159-167-180-206	523	980	452	750/2,200	19/23	-	107-125-160-180	107-160
FW180	206-281	787	1,650	636	1,200	35	-	180	-
FW220	97-119-165-190-248-290-345	765	1,660	740	1,200	15	-	107-180	160-200-250
FW260	69-97-245-251-345	750	1,560	865	1,000	15	-	-	355-250
FW360	24-94-128-223-257-490	1,040	2,450	1,080	1,700	12	-	355	355

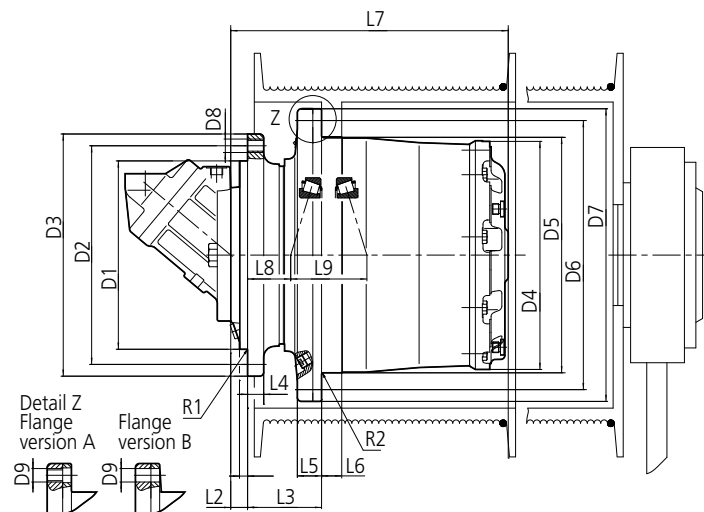

Type	L1	L2	L3	L4	L5	L6	L7	L8	L9	R1	R2	D1	D2	D3	D4	D5	D6	D7	D8	D9 Vers. A	D9 Vers. B	Qty. D8/D9
FW130	45	45	190	35	58	45	530	50.5	147	25	4	390	500	550	449	450	500	550	M24x2	M24x2	26	32/32
FW180	30	30	168	40	56	21.5	534.5	50.3	141.4	4	3	450	510	560	528	535	600	650	M24x2	M24x2	26	30/30
FW220	18	52	166.5	40	61	35	580.5	16	187.5	35°/16/16	4	460	600	650	540	542	600	650	M24x2	M24x2	26	38/38
FW260	21	45	170	40	48	60	579	18.5	189.5	2	-	460	520	570	608	610	680	735	M30x2	M30x2	32	24/24
FW360	100	100	130	40	60	80	658	-25	215	18°/100/16	10	580	680	735	649	650	720	775	M30x3.5	M30x3.5	32	30/30

1) Other ratios on demand  
2) Without Hydraulic motor

3) Optional brake torques on demand  
4) Option: external brake

## Winch drives

Winch system for vertical drills with external or internal brake



Machine weight tons	Winch Drive
Up to 15	FW13
15-20	FW30
20-28	FW30
28-33	FW40
33-40	FW40
40-50	FW55
50-70	FW80
70-80	FW130
80-100	FW130
100-120	FW180
120-150	FW180
150-180	FW220
180-200	FW620
200-300	FW1100

# Winch drives



## Winch system for harbour cranes

### General requirements

- Planetary drive
- Winch drum
- Dynamic safety brake & elastic couplings
- Winch drum support / Torque arm
- Motor support for IEC electric motor

		F560TPS	F260TPS
Ratio gearbox	(-)	38.462	36
Nominal load	t	50	32
FEM - CLASS	(-)	M8 - T9	M8 - T7
Requested lifetime according FEM	h	50000	25000
Drum winding diameter	mm	950	725
Rope diameter	mm	38	29
Nominal torque	Nm	129941	65166
Max rope speed (empty)	m/min	140	120
Max torque (grab bulk mode)	Nm	253700	155800
Max drum speed (grab bulk mode)	U/min	14	23,7
Max torque (cargo mode)	Nm	259900	130300
Max drum speed (cargo mode)	U/min	36.9	35.2

## Other drives



### FTU Series

#### Torque units and tunneling drives

The FTU Series are perfectly suited to tunnel boring machines and large mining equipment. Robust, powerful and durable these drives are matching all the requirements of this specific application.



HYDRAULIC SOLUTIONS

#### Gear ratios

- 19.8 ... 1500

#### Standard features

- Compact structure
- High performance
- 3–7 Planetary wheels per stage
- Notchless ground tooth root
- Different ratios
- Different input options
- Different output options
- Optional integrated disc-brake

#### Special executions on request

- Water jacket
- Oil & air cooling system
- Safety clutch

#### Torque $T_{Nom}$ (kNm)

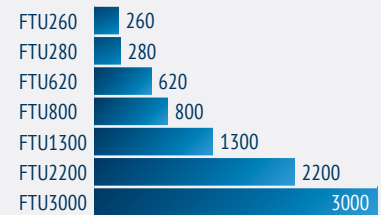

## Overall dimensions and technical data

Type	Ratio - Range	Input options	Output options
	(-)		
FTU260	52 ... 1,500	(1)	(2)
FTU280	57 ... 1,500	(1)	(2)
FTU620	24 ... 1,500	(1)	(2)
FTU800	24.5 ... 1,500	(1)	(2)
FTU1300	34.7 ... 1,500	(1)	(2)
FTU2200	19.8 ... 1,500	(1)	(2)
FTU3000	19.8 ... 1,500	(1)	(2)

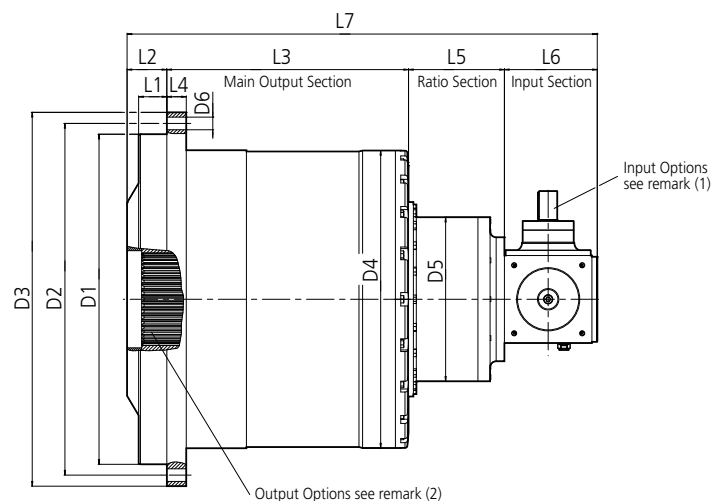

Type	L1	L2	L3	L4	L5	L6	L7	D1	D2	D3	D4	D5	D6	Qty. D6
FTU260	15	340	650	65	(3)	(3)	990	630	690	750	660	(3)	26	36
FTU280	31	646	365	60	(3)	(3)	1011	630	770	820	600	(3)	26	36
FTU620	60	95	640	54	(3)	(3)	(3)	895	1000	1060	885	(3)	33	36
FTU800	65	100	730	58	(3)	(3)	(3)	955	1010	1090	920	(3)	33	48
FTU1300	80	110	938	75	(3)	(3)	(3)	1240	1330	1430	1224	(3)	45	52
FTU2200	125	142.5	1112	100	(3)	(3)	(3)	1340	1440	1540	1216	(3)	45	48
FTU3000	125	142.5	1112	80	(3)	(3)	(3)	1340	1440	1540	1216	(3)	45	48

- 1) Input options:**  
 Hydraulic Motor  
 Electric Motor  
 Angular / Bevel Gear  
 Spline Shaft  
 Spline Hollow Shaft  
 Hollow Shaft Shrink Disk  
 Key Shaft  
 Flange

- 2) Output options:**  
 Spline Shaft  
 Spline Hollow Shaft  
 Hollow Shaft Shrink Disk  
 Key Shaft  
 Flange

- 3) Depending on ratio and input/output option**

# Other drives

## Jack-up drives

The specific design of the O&K Jack-up Series has been assessed by ABS to work in lifting and lowering legs and hulls of drilling and service jack up rigs, lift boats and windmill installation vessels. Units can be in-line or have a drop box for offsetting the motor installation. They can be electrically or hydraulically driven, with or without a negative parking brake. These jack-up drives can deliver integrated pinions from m50 to m100 and lantern pieces with integrated torque arm for easy installation. Units have class approval from ABS and DNV GL, and full 3.2 certification of the load-bearing parts of the gear transmission with full traceability from raw material to final machined component.



HYDRAULIC SOLUTIONS



ELECTRIC SOLUTIONS



### Max. jacking load

- 560 metric tons / 600 short tons / 1,230 Kips

### Max. holding torque

- Up to 2,400 kNm

### Max. storm holding torque

- Up to 2,900 kNm

### Applicable motors

- Piston hydraulic motors
- Electric motors IEC

### Max jacking (kNm)

JD2400  1900

Overall dimensions and technical data

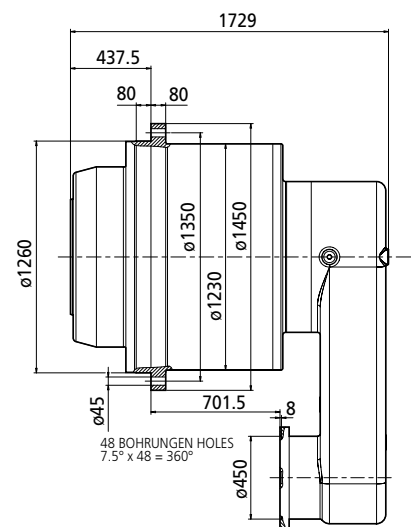
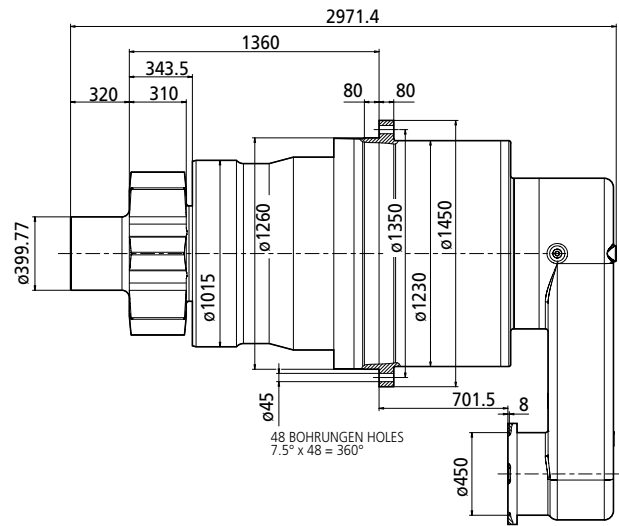

## Matching products/applications charts

### Excavator travel drive CE

Excavator weight tons	Track Drive	Slew Drive
6-8	F10	S5
8-10	F13	S5
10-12	FD20	S5
12-18	F30	S7
18-22	F40	S10
22-28	F55	S13
28-35	F80	S17
35-50	F100	S30
50-70	F130	S30
70-90	F180	S34

### Trencher

Machine weight tons	Track Drive
20-30	F55
30-40	F80
40-50	F100
50-80	F130
80-100	F180
100-120	F220
120-150	F280
150-180	F360

### Crusher / Screener

Machine weight tons	Track Drive
20-30	F30
30-40	F40
40-50	F55
50-70	F80
70-90	F100
90-110	F130

### Towing tractors

Maximum output torque	Wheel Drives	Aircraft weight
19	FR20	160 ton
23	FR40	300 ton
30	FR60	600 ton

### Excavator travel drive mining

Excavator weight tons	Track Drive	Slew Drive
50-70	F130	S30
70-90	F180	S34
90-120	F220	S54 (1x)
120-150	F280	S54 (1x)
150-180	F360	S54 (2x)
180-220	F420	S54 (2x)
220-300	F620	S54 (3x)
300-400	F800	S54 (3x)
400-500	F1100	S54 (4x)
500-600	F1300	S54 (4x)
600-800	F1800	S54 (5x)
800-1000	F2200	S54 (6x)
1200-1400	F3000	S130 (4x)

### Crawler crane

Crane lifting capacity tons	Travel Drive	Winch Drive
40	F80 (2x)	FW80
80	F100 (2x)	FW80
100	F130 (2x)	FW100
130	F180 (2x)	FW100
160	F260 (2x)	FW130
250	F440 (2x)	FW130
300	F560 (2x)	FW180
350	F620 (2x)	FW220
400	F650 (2x)	FW220
600	F700 (2x)	FW220
600	F740 (2x)	FW260
800	F560 (4x)	FW260
1200	F750 (4x)	FW220 (2x)
2500	F1800 (4x)	FW220 (2x)
4000	F2200 (4x)	FW360 (2x)



# Matching products/applications charts

## Excavator Travel Compact Drives

Machine weight tons	Track Drive
14-18	F30K
18-22	F45K
22-28	F55K
28-35	F80K
35-50	F100K

## Drilling Rigs

Machine weight tons	Track Drive	Slew Drive	Winch Drive
Up to 15	FD20	S5	FW13
15-20	F30	S7	FW30
20-28	F40	S10	FW30
28-33	F40	S13	FW40
33-40	F55	S17	FW40
40-50	F80	S20	FW55
50-70	F100	S30	FW80
70-80	F100	S30	FW130
80-100	F130	S20 (2x)	FW130
100-120	F180	S20 (2x)	FW180
120-150	F220	S54	FW180
150-180	F280	S20 (3x)	FW220
180-200	F360	S20 (3x)	FW620
200-300	F620	S54 (3x)	FW1100

## Paver

Machine weight tons	Track Drive
Up to 10	FD20
10-14	F30
14-20	F40
20-24	F55
24-33	F80

## Soil Compactor

Machine weight tons	Drum Drive
2.5-5	n.a.
5-7	F10
7-9	FD20
9-12	F30
12-16	F40
16-18	F55
18-20	F80
20-25	F100

## Road Milling Machine / Surface Mining Machine - by weight

Machine weight tons	Track Drive
5-8	F10
8-25	F30
25-36	F55
36-45	F80

## Vibrating Tandem Roller

Machine weight tons	Track Drive
1-1.5	n.a.
1.5-2.5	n.a.
2.5-5	n.a.
5-7.5	F10
7.5-12	FD20
12-13	F30
13-15	F40
15-17	F55
17-20	F80

## Road Milling Machine / Surface Mining Machine - by input power

Input power kW	Cutter Drive	Cutting Torque
80	FA30	8.5 kNm
110	FA40	12 kNm
150	FA55	16 kNm
220	FA80	23 kNm
300	FA100	32 kNm
400	FA130	38 kNm
500	FA200	47 kNm
880	FA360	84 kNm
1200	FA800	115 kNm

# Global Presence



Bonfiglioli is a market force with a presence spanning 22 countries on 5 continents. Our organization makes the most of geographic proximity to offer complete solutions combining efficiency and competence.



3700  
EMPLOYEES



21  
BRANCHES



14  
PLANTS



550  
DISTRIBUTORS



80  
COUNTRIES

## We Are a Global Company

Thanks to an international network of sales branches and closely interconnecting production plants, we can guarantee the same high standards of Bonfiglioli quality anywhere at any given time. Aware that our direct presence in local markets is the key to long-lasting success, our family includes 21 sales branches, 14 production plants and more than 500 distributors around the world.

**Our organization is always close by, offering complete and efficient solutions and supporting our customers with dedicated services, such as co-engineering or after-sales assistance.**



# Bonfiglioli Worldwide Locations

## Australia

### **Bonfiglioli Transmission (Aust.) Pty Ltd**

2, Cox Place Glendenning NSW 2761  
Locked Bag 1000 Plumpton NSW 2761  
Tel. +61 2 8811 8000

## Brazil

### **Bonfiglioli Redutores do Brasil Ltda**

Travessa Cláudio Armando 171 - Bloco 3 - CEP 09861-730  
Bairro Assunção - São Bernardo do Campo - São Paulo  
Tel. +55 11 4344 2322

## China

### **Bonfiglioli Drives (Shanghai) Co. Ltd.**

#68, Hui-Lian Road, QingPu District,  
201707 Shanghai  
Tel. +86 21 6700 2000

## France

### **Bonfiglioli Transmission s.a.**

14 Rue Eugène Pottier  
Zone Industrielle de Moimont II - 95670 Marly la Ville  
Tel. +33 1 34474510

## Germany

### **Bonfiglioli Deutschland GmbH**

Sperberweg 12 - 41468 Neuss  
Tel. +49 0 2131 2988 0

### **Bonfiglioli Vectron GmbH**

Europark Fichtenhain B6 - 47807 Krefeld  
Tel. +49 0 2151 8396 0

### **O&K Antriebstechnik GmbH**

Ruhrallee 8-12 - 45525 Hattingen  
Tel. +49 0 2324 2050 1

## India

### **Bonfiglioli Transmission Pvt Ltd**

Plot No. AC7-AC11, SIDCO Industrial Estate,  
Thirumudivakkam - 600 044 Chennai  
Tel. +91 44 2478 1035

### **Industrial**

Survey No. 528, Porambakkam High Road,  
Mannur Village, Sriperambudur Taluk - 602 105 Chennai  
Tel. +91 44 6710 3800  
Plot No. A-95, Phase IV, MIDC Chakan, Village Nighoje  
Pune, Maharashtra - 410 501

## Italy

### **Bonfiglioli Riduttori S.p.A.**

#### **Headquarters**

Via Giovanni XXIII, 7/A - 40012 Lippo di Calderara di Reno  
Tel. +39 051 647 3111

#### **Mobile, Wind**

Via Enrico Mattei, 12 Z.I. Villa Selva - 47100 Forlì  
Tel. +39 0543 789111

#### **Industrial**

Via Bazzane, 33/A - 40012 Calderara di Reno  
Tel. +39 051 6473111  
Via Trinità, 1 - 41058 Vignola  
Tel. +39 059 768511

### **Bonfiglioli Italia S.p.A**

Via Sandro Pertini lotto 7b - 20080 Carpiano  
Tel. +39 02 985081

### **Bonfiglioli Mechatronic Research S.p.A**

Via F. Zeni 8 - 38068 Rovereto  
Tel. +39 0464 443435/36

## New Zealand

### **Bonfiglioli Transmission (Aust.) Pty Ltd**

88 Hastie Avenue, Mangere Bridge, 2022 Auckland  
PO Box 11795, Ellerslie  
Tel. +64 09 634 6441

## Singapore

### **Bonfiglioli South East Asia Pte Ltd**

8 Boon Lay Way, #04-09,  
8@ Tadehub 21, Singapore 609964  
Tel. +65 6268 9869

## Slovakia

### **Bonfiglioli Slovakia s.r.o.**

Robotnícka 2129  
Považská Bystrica, 01701 Slovakia  
Tel. +421 42 430 75 64

## South Africa

### **Bonfiglioli South Africa Pty Ltd**

55 Galaxy Avenue, Linbro Business Park - Sandton  
Tel. +27 11 608 2030

## Spain

### **Tecnotrans Bonfiglioli s.a**

Pol. Ind. Zona Franca, Sector C, Calle F, nº 6  
08040 Barcelona  
Tel. +34 93 447 84 00

## Turkey

### **Bonfiglioli Turkey Jsc**

Atatürk Organize Sanayi Bölgesi, 10007 Sk. No. 30  
Atatürk Organize Sanayi Bölgesi, 35620 Çiğli - Izmir  
Tel. +90 0 232 328 22 77

## United Kingdom

### **Bonfiglioli UK Ltd.**

1 Calver Quay, Winwick  
Warrington - WA2 8UD  
Tel. +44 1925 825667

## USA

### **Bonfiglioli USA Inc.**

3541 Hargrave Drive  
Hebron, Kentucky 41048  
Tel. +1 859 334 3333

## Vietnam

### **Bonfiglioli Vietnam Ltd**

Lot C-9D-CN My Phuoc Industrial Park 3  
Ben Cat - Binh Duong Province  
Tel. +84 650 3577411



We have a relentless commitment to excellence, innovation and sustainability. Our team creates, distributes and services world-class power transmission and drive solutions to keep the world in motion.

#### **HEADQUARTERS**

Bonfiglioli Riduttori S.p.A.  
Via Giovanni XXIII, 7/A  
40012 Lippo di Calderara di Reno  
Bologna (Italy)  
[www.bonfiglioli.com](http://www.bonfiglioli.com)

