



500 series Transit mixer drives

When you cannot afford any down time, then quality is the top priority. Absolute dependability, low maintenance, compactness and price effectiveness are the key features of the renovated 500 series, the unparalleled line of drives for transit mixers. Eight models available for mixing capacity ranging from 1 to 12 m³.



Type	Torque [Nm]
501	3000
564	12000
565	12000
567	20000
568	20000
575	50000
577	60000
580	75000



Torque Range

3000 ... 75000 Nm

Truck mixer capacity

1 to 12 cubic meters

Gear Ratios

17 ... 161

Key Features

Rotating housing flange

Rugged design

High torque capacity

High load capacity

Tilting output flange, evenly in all directions

Mounting frame for water tank

Water pump P.T.O.

Speed sensor

Applicable hydraulic motors

Axial piston motors to SAE Standard orbit motors

Type	Range of ratios	Hydraulic motor drive	Max. input speed	Drum capacity	Weight	Oil quantity	Design	Water pump P.T.O.	Speed sensor
	1:	(1)	min -1	(2)	Kg	L			
501	17-23-29	LS	550	0.5 - 1	45	1.5	A	-	-
564	78-161	HS	2500	2 - 3	85	2	A	-	-
565	22	LS	550	2 - 3	70	1.5	A	-	-
567	76-90-115-128	HS	2500	4 - 5	140	3	A	-	-
568	18-21-27	LS	550	4 - 5	130	2.5	A	-	-
575	99.3-102-141	HS	3000	6 - 8	250	7	B	•	•
577	131	HS	3000	8 - 10	290	8.5	B	•	•
580	130-135-140	HS	3000	10 - 12	320	10	B	•	•

(1) LS = Low speed motor, HS = High speed motor

(2) General indication, application capacity depend on concrete slump

- = Not available

• = Available

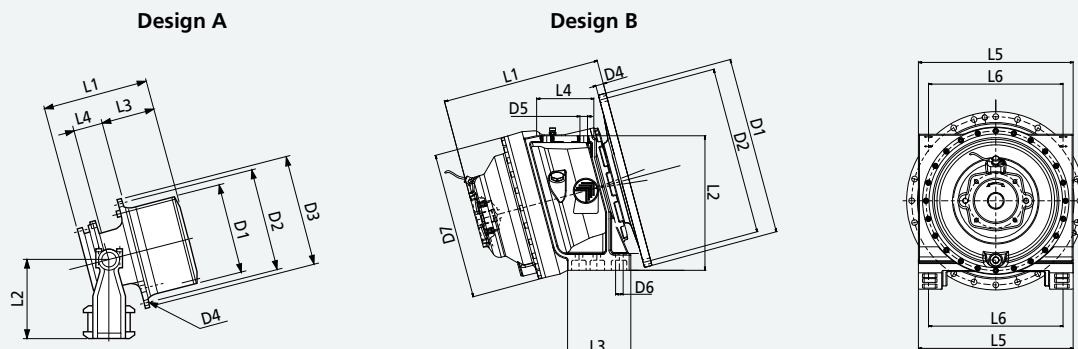

Type	D1	D2	D3	D4	D5	D6	D7	L1	L2	L3	L4	L5	L6
501	200	222	245	13 n°4	-	-	-	270	195	138	89	-	-
564	280	310	340	17 n°10	-	-	-	365	240	165	85	-	-
565	280	310	340	17 n°10	-	-	-	290	240	165	85	-	-
567	358	390	430	17 n°18	-	-	-	435	300	210	110	-	-
568	358	390	430	17 n°18	-	-	-	360	300	210	110	-	-
575	530	500	-	17 n°24	22 n°4	22 n°6	435	450	400	188	170	460	400
577	530	500	-	17 n°24	22 n°4	22 n°6	435	450	400	188	170	460	400
580	530	500	-	17 n°24	22 n°4	22 n°6	435	525	400	188	170	460	400