

700TK series Slew drives for excavator duty



Torque Range: 750 ... 9.000 Nm
Excavator weight: 1,5 to 20 ton.
Gear Ratios: 7 ... 40
Key Features
 Flange mounted
 Output shaft with integral pinion
 Rugged construction
 High torque capacity
 Output shafts supported by heavy duty bearings
 Compact design
Hydraulic motors
 KAYABA hydraulic motor fixed displacement complete with shockless type pressure relief valve
Motor options
 Anti swing-back valve
Brake
 Hydraulically released failsafe parking brake
 Brake retarder valve on request

Type	Max. Torque Nm	Motor displacement cm	Max. pressure bar	Max. flow l/min	Parking brake		Range of ratio 1:	Approx. weight of machine ton
					Yes	No		
700 T1 K - 27	750	27.4	210	18	•	•	8.2	1,5 - 2,5
701 T2 K - 27	1200	27.4	210	30	•	•	13,7-20,8	3 - 4
703 T2 K - 27	2000	27.4	250	50	•	•	14,8-35,6	5 - 6
705 T2 K - 44	4000	44.1	280	80	•	•	18-26,3	7 - 8
706 T2 K - 63	6000	62.9	280	120	•	•	15,3-33	9 - 10
706 T2 K - 85	7000	87.3	320	160	•	•	15,3-22,6	11 - 13
707 T2 K - 85	9000	87.3	320	160	•	•	14,7-22,3	15 - 18

New technical data and dimension.

OVERALL DIMENSIONS

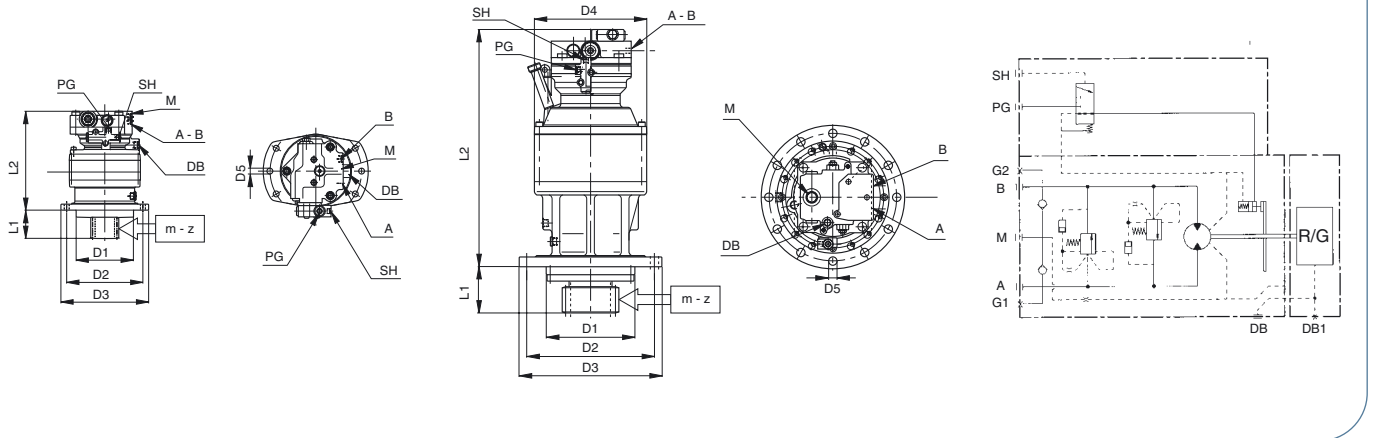

Type	Dimensions												
	D1	D2	D3	D4	D5	L1	L2	A-B	DB	M	SH	PG	m z
700 T1 K - 27		228	260	186	∅ 13 n°6	76	221	MAIN PORT	DRAIN PORT	ANTICAVITATION PORT	SPOOL OPERATING PORT	BRAKE RELEASE PORT	Module / number of teeth of pinion UPON REQUEST
701 T2 K - 27	175	228	260	186	∅ 13 n°6	86	256						
703 T2 K - 27	175	245	272	244	∅ 18 n°10	120	330						
705 T2 K - 44	230	245	272	244	∅ 18 n°10	120	420						
706 T2 K - 63	230	332	372	292	∅ 22 n°10	150	580						
706 T2 K - 85	270	332	372	292	∅ 22 n°10	150	615						
707 T2 K - 85		360	410	348	∅ 22 n°12	160	580						

HEADQUARTERS
BONFIGLIOLI RIDUTTORI
 Via Giovanni XXIII, 7/A
 40012 Lippo di Calderara di Reno
 Bologna (ITALY)
 Tel. (+39) 051 6473111
 Fax (+39) 051 6473126
 www.bonfiglioli.com

SALES DEPARTMENT
BONFIGLIOLI RIDUTTORI S.p.A.
 Via Enrico Mattei, 12 - Z.I. Villa Selva
 47100 Forlì (ITALY)
 Tel. (+39) 0543 789111
 Fax (+39) 0543 789242 - 0543 789245
 trasmital@bonfiglioli.com

