

Classical Timing Belt Pulleys



Classical Timing Belt Pulleys have evenly spaced grooves cut in their periphery, to make correct, positive engagement with the mating teeth of the belt. Cross & Morse pulleys are manufactured with involute groove form to enable the teeth to enter and leave the pulley with negligible friction and minimum backlash.

Pulleys are available in a number of stock widths and large selection of numbers of teeth to provide maximum versatility in drive selection. Pulleys for 3/8" pitch 'L', and 1/2" pitch 'H', drives are available with pilot bore for reworking to customers requirements or with taper bush for the complete off the shelf drive. All pulleys are precision manufactured to close tolerances to ensure concentric running, and it is important when reworking stock pulleys to accurately locate on the outside diameter to maintain concentricity.

Pulleys of non-standard widths or numbers of teeth can be supplied to order, or alternately teeth can be cut on customers blanks. All pulleys are manufactured in good quality steel except for larger pulleys where cast iron is used (1/5" pitch 'XL' are also available in aluminium. Generally pulleys up to 48 teeth are supplied with two flanges to retain the timing belt. These flanges are accurately machined, pressed onto the pulley bodies and retained by spin rivetting. Dimensions over and between flanges for standard pulleys are indicated below. The dimension over the flanges is generally the same as recommended width of tooth for unflanged pulleys.

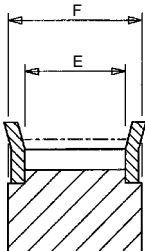

Belt Size	(1/5") XL				(1/2") H			
Belt Width Ref.	XL037	L050	L075	L100	H100	H150	H200	H300
Belt Width	3/8"	1/2"	3/4"	1"	1"	1 1/2"	2"	3"
E	10.7	14.3	20.8	27.0	27.0	40.0	53.0	79.0
F min.	14.3	19.0	25.5	32.0	32.0	45.0	58.0	84.0

Standard Pulleys for XL (1/5" pitch) Belts

Pulley Types available in both steel and aluminium. For steel add 'C' to part number, for aluminium add 'L'.

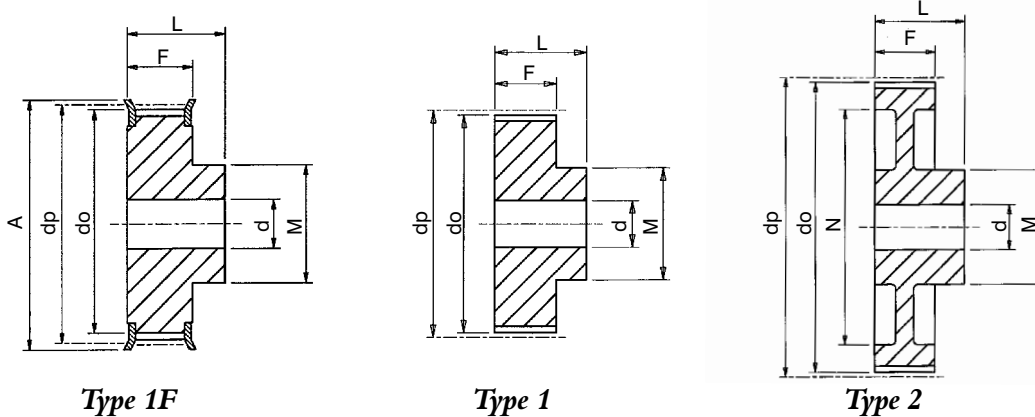

Type 1F

Type 1

Type 2

Catalogue No.	No. Teeth Z	Pulley Type	Pitch Circle Dia. dp	Min. Bore d	Max. Bore d	Outside Diameter do	Flange Diameter A	Pulley Width F	Bore Length L	Hub Diameter M	Rim Diameter N	Approx Weight kg
1/5" Pitch Pulleys for 3/8" Wide Belts. Ref. XL037												
10XL037	10	1F	16.17	4.0	6	15.7	23	14.3	20.0	9.5	-	0.02
11XL037	11	1F	17.79	4.0	6	17.3	23	14.3	20.0	9.5	-	0.02
12XL037	12	1F	19.40	4.0	7	18.9	25	14.3	20.0	10.0	-	0.03
13XL037	13	1F	21.02	4.0	7	20.5	28	14.3	20.0	10.0	-	0.04
14XL037	14	1F	22.64	4.0	10	22.1	28	14.3	20.0	15.0	-	0.05
15XL037	15	1F	24.26	6.0	10	23.8	28	14.3	20.0	15.0	-	0.05
16XL037	16	1F	25.87	6.0	10	25.4	32	14.3	20.0	16.0	-	0.06
17XL037	17	1F	27.49	6.0	13	27.0	35	14.3	20.0	20.0	-	0.07
18XL037	18	1F	29.11	6.0	13	28.6	35	14.3	20.0	20.0	-	0.08
19XL037	19	1F	30.72	6.0	13	30.2	38	14.3	22.0	20.0	-	0.09
20XL037	20	1F	32.34	6.0	15	31.8	38	14.3	22.0	23.5	-	0.11
21XL037	21	1F	33.96	6.0	15	33.5	38	14.3	22.0	23.5	-	0.12
22XL037	22	1F	35.57	6.0	16	35.1	41	14.3	22.0	25.0	-	0.13
24XL037	24	1F	38.81	6.0	20	38.3	44	14.3	22.0	30.0	-	0.15
26XL037	26	1F	42.04	8.0	20	41.5	48	14.3	22.0	30.0	-	0.19
27XL037	27	1F	43.66	8.0	20	43.2	48	14.3	22.0	30.0	-	0.20
28XL037	28	1F	45.28	8.0	22	44.8	51	14.3	22.0	34.0	-	0.22
30XL037	30	1F	48.51	8.0	25	48.0	54	14.3	22.0	38.0	-	0.24
32XL037	32	1F	51.74	8.0	25	51.2	57	14.3	25.0	38.0	-	0.12
34XL037	34	1	54.98	8.0	29	54.5	-	14.3	25.0	45.0	-	0.12
35XL037	35	1	56.60	8.0	29	56.1	-	14.3	25.0	45.0	-	0.13
36XL037	36	1	58.21	8.0	29	57.7	-	14.3	25.0	45.0	-	0.14
38XL037	38	1	61.45	8.0	29	61.0	-	14.3	25.0	45.0	-	0.16
40XL037	40	1	64.68	8.0	29	64.2	-	14.3	25.0	45.0	-	0.17
42XL037	42	1	67.91	8.0	29	67.4	-	14.3	25.0	45.0	-	0.18
44XL037	44	1	71.15	8.0	29	70.6	-	14.3	25.0	45.0	-	0.19
48XL037	48	2	77.62	10.0	29	77.1	-	14.3	25.0	45.0	61	0.21
60XL037	60	2	97.02	10.0	29	96.5	-	14.3	25.0	45.0	80	0.25
72XL037	72	2	116.43	10.0	29	115.9	-	14.3	25.0	45.0	100	0.30

All dimensions in mm.

Taper Bore Pulleys for 'L' Series Timing Belts



Catalogue No.	No. Teeth Z	Pulley Type	Pitch Circle Diameter dp	Taper Bush Size	Max Bore d	Outside Diameter do	Flange Diameter A	Pulley Width F	Bore Length L	Hub Diameter M	Rim Diameter N	Approx. Weight kg
3/8" Pitch Pulleys for 1/2" wide Belts. Ref. L050												
18L050	18	8F	54.57	1108	28	53.8	60	19	22	45	-	0.17
19L050	19	8F	57.61	1108	28	56.8	64	19	22	45	-	0.20
20L050	20	8F	60.64	1108	28	59.9	67	19	22	48	-	0.23
21L050	21	8F	63.67	1108	28	62.9	70	19	22	48	-	0.30
22L050	22	8F	66.70	1108	28	65.9	75	19	22	51	-	0.36
23L050	23	8F	69.73	1108	28	69.0	79	19	22	54	-	0.41
24L050	24	8F	72.77	1108	28	72.0	79	19	22	54	-	0.45
25L050	25	8F	75.80	1108	28	75.0	83	19	22	56	-	0.50
26L050	26	8F	78.83	1108	28	78.1	86	19	22	60	-	0.55
27L050	27	8F	81.86	1108	28	81.1	86	19	22	62	-	0.61
28L050	28	8F	84.89	1108	28	84.1	91	19	22	65	-	0.68
30L050	30	8F	90.96	1108	28	90.2	97	19	22	70	-	0.82
32L050	32	8F	97.02	1108	28	96.3	102	19	22	74	-	0.98
36L050	36	8F	109.15	1108	28	108.4	115	19	22	85	-	1.38
40L050	40	8F	121.28	1610	42	120.5	128	19	25	88	-	1.75
48L050	48	11F	145.53	1610	42	144.8	150	19	25	88	120	1.76
60L050	60	7	181.91	1610	42	181.2	-	19	25	92	166	2.18
72L050	72	7	218.30	1610	42	217.5	-	19	25	92	202	3.00
84L050	84	7	254.68	1610	42	253.9	-	19	25	92	236	4.00
96L050	96	7	291.06	2012	50	290.3	-	19	32	106	270	5.50
120L050	120	7	363.83	2012	50	363.1	-	19	32	106	343	6.80
3/8" Pitch Pulleys for 3/4" wide Belts. Ref. L075												
18L075	18	9F	54.57	1108	28	53.8	60	25	25	-	-	0.24
19L075	19	9F	57.61	1108	28	56.8	64	25	25	-	-	0.28
20L075	20	9F	60.64	1108	28	59.9	67	25	25	-	-	0.33
21L075	21	9F	63.67	1108	28	62.9	70	25	25	-	-	0.38
22L075	22	9F	66.70	1108	28	65.9	75	25	25	-	-	0.45
23L075	23	9F	69.73	1108	28	69.0	79	25	25	-	-	0.52
24L075	24	9F	72.77	1108	28	72.0	79	25	25	-	-	0.58
25L075	25	9F	75.80	1108	28	75.0	83	25	25	-	-	0.64
26L075	26	9F	78.83	1108	28	78.1	86	25	25	-	-	0.71
27L075	27	9F	81.86	1108	28	81.1	86	25	25	-	-	0.79
28L075	28	9F	84.89	1108	28	84.1	91	25	25	-	-	0.86
30L075	30	9F	90.96	1108	28	90.2	97	25	25	-	-	1.04
32L075	32	9F	97.02	1108	28	96.3	102	25	25	-	-	1.21
36L075	36	9F	109.15	1610	42	108.4	115	25	25	-	-	1.41
40L075	40	9F	121.28	1610	42	120.5	128	25	25	-	-	1.86
48L075	48	10F	145.53	1610	42	144.8	150	25	25	92	120	2.50
60L075	60	10	181.91	1610	42	181.2	-	25	25	92	166	3.00
72L075	72	10	218.30	1610	42	217.5	-	25	25	92	202	4.00
84L075	84	7	254.68	2012	50	253.9	-	25	32	92	236	5.20
96L075	96	7	291.06	2012	50	290.3	-	25	32	106	270	6.50
120L075	120	7	363.83	2012	50	363.1	-	25	32	106	343	7.60
3/8" Pitch Pulleys for 1" wide Belts. Ref. L100												
18L100	18	5F	54.57	1108	28	53.8	60	31	22	-	38	0.25
19L100	19	5F	57.61	1108	28	56.8	64	31	22	-	38	0.31
20L100	20	5F	60.64	1108	28	59.9	67	31	22	-	45	0.36
21L100	21	5F	63.67	1108	28	62.9	70	31	22	-	45	0.41
22L100	22	5F	66.70	1108	28	65.9	75	31	22	-	48	0.47
23L100	23	5F	69.73	1108	28	69.0	79	32	22	-	52	0.53
24L100	24	5F	72.77	1108	28	72.0	79	32	22	-	52	0.60
25L100	25	5F	75.80	1108	28	75.0	83	32	22	-	54	0.67
26L100	26	5F	78.83	1108	28	78.1	86	32	22	-	60	0.73
27L100	27	5F	81.86	1108	28	81.1	86	32	22	-	60	0.80
28L100	28	5F	84.89	1108	28	84.1	91	32	22	-	65	0.87
30L100	30	5F	90.96	1210	32	90.2	97	32	25	-	71	0.98
32L100	32	5F	97.02	1210	32	96.3	102	32	25	-	75	1.18
36L100	36	5F	109.15	1610	42	108.4	115	32	25	-	86	1.42
40L100	40	5F	121.28	1610	42	120.5	128	32	25	-	96	1.70
48L100	48	14F	145.53	1610	42	144.8	150	32	25	92	120	2.70
60L100	60	12	181.91	1610	42	181.2	-	32	25	92	166	2.40
72L100	72	10	218.30	2012	50	217.5	-	32	32	92	202	4.40
84L100	84	10	254.68	2012	50	253.9	-	32	32	92	236	6.00
96L100	96	10	291.06	2012	50	290.3	-	32	32	106	270	7.10
120L100	120	10	363.83	2012	50	363.1	-	32	32	106	343	8.50

All dimensions in mm. For Taper Bush dimensions refer page 25.

Pulley Types

Pulley types referred to in tables are as drawings below. The suffix 'F' indicates pulley has flanges. Pulleys below dividing line in tables are manufactured in cast iron. Types 7, 10 & 12 when in cast iron have lightening holes.

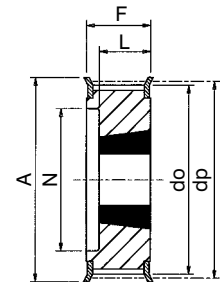

Type 5F

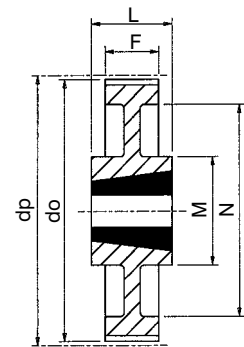

Type 7

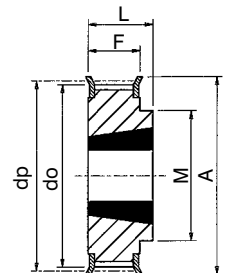

Type 8F

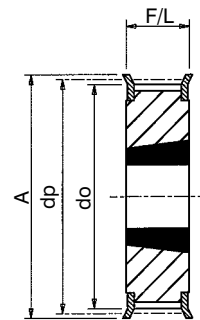

Type 9F

Pulley Installation

Correct and accurate installation of Timing Drives is essential. Pulley alignment and shaft parallelism is very important as misalignment of the drive will cause unequal loading across the belt width and edge wear of belt on flanges. Pulley alignment can be checked by placing a straight edge against the outside edge of the pulleys and adjusting so contact made evenly across both pulleys.

The shaft should be located within a rigid framework, as any distortion under load could result in a reduction of centre distance which will cause jumping of belt on pulley teeth. If idlers are used they must be locked firmly into position after correct belt tensioning.

Refer to page 10 for additional information on drive installation.

Tel +44 121 360 0155

Fax +44 121 325 1079

Email sales@crossmorse.com

