

Serie Protection

SR770

Nylon Protection Cable Chain with openable covers

Inner height (D) 51 mm
 Double share Sideband & Frame construction with large anti-friction single-pin. Covers are openable from inner radius.
 Vertical separators are available.

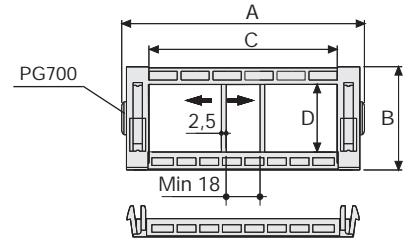
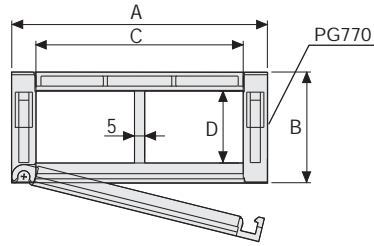

Separator	
- Unassembled	Part.no S770
- Assembled	Part.no S770MC

Separator	
- Unassembled	Part.no S700
- Assembled	Part.no S700MC

Technical characteristics when self-supported

Speed	6 m/s
Acceleration	30 m/s ²

For higher requirements please consult our technical dept.

A	B	C	D	R	Weight/m	Chain
mm	mm	mm	mm	mm	kg	Part Number
120	78	85	51	150-200-250-300	3,30	SR770085□□□*
135	78	100	51	150-200-250-300	3,90	SR770100□□□*
185	78	150	51	150-200-250-300	4,10	SR770150□□□*
235	78	200	51	150-200-250-300	4,50	SR770200□□□*
285	78	250	51	150-200-250-300	5,00	SR70025□□**

*Complete the code by inserting the value of the radius (R): Ex. SR770085 □ □ □ □

**Complete the code by inserting the value of the radius (R): Ex. SR70025 □ □

Where: 0=150; 1=200; 2=250; 3=300

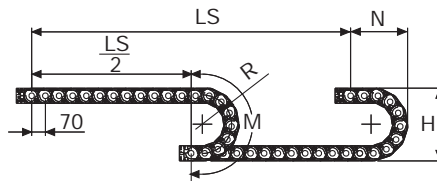

R	H	N	M
mm	mm	mm	mm
150	378	260	615
200	478	310	770
250	578	365	930
300	678	410	1085

Length of chain (L)
 Half travel distance ($\frac{LS}{2}$)
 plus length of curve (M)

$$L = \frac{LS}{2} + M$$



Self-Supporting Capacity Diagram

The maximum length of the self-supporting capacity ($\frac{LS}{2}$) in relationship to the weight of the cables and hoses contained per linear metre.

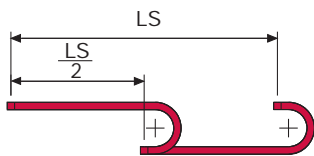
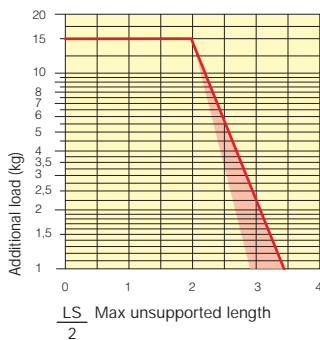

The red marking in the diagram area considers the difference of weight between various widths of chain.

For applications with $\frac{LS}{2}$ and weights not included in the area of the diagram showing self-supporting capacity, verify the possible use of support rollers (see page 30).

End Brackets

The end brackets set allows the two ends of the chain to be attached to the equipment.

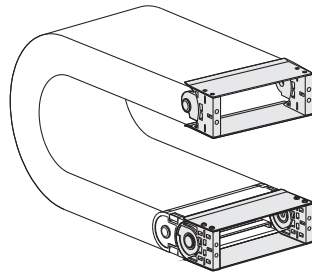
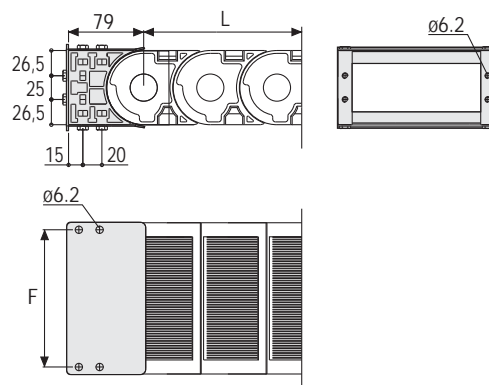

Fig. A
The chain can be fixed frontally, inner or outer radius. (Fig A)



Chain Type	F mm
SR770 C=85	100
SR770 C=100	115
SR770 C=150	165
SR770 C=200	215
SR700 C=250	265

Nylon Type Part Numbers

Complete Set Assembled	
Chain Type	End Brackets Set
SR770...	AN770□□□*KM
SR700 C=250	AL700KM

Complete Set Unassembled	
Chain Type	End Brackets Set
SR770...	AN770□□□*K
SR700 C=250	AL700K

* Complete the code by inserting the value of the quote C.

Serie Protection

SR770

Nylon Protection Cable Chain with openable covers

3

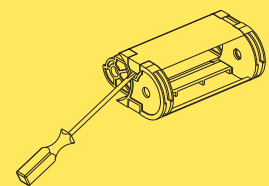
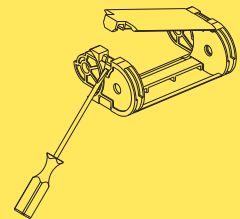

How to open the cover.

Special tool to remove the connecting pivots:
Part Number PZ010.



For further information please consult Brevetti Stendalto's Technical Office