

Serie Protection

SR308CI/SR308CE Nylon Protection Cable Chain with openable aluminium covers

Inner height (D) 57 mm
Strong double share Sideband & Frame construction with large anti-friction triple-pin.
Covers are openable from inner radius (SR308CI) or from outer radius (SR308CE).
Vertical separators are available.

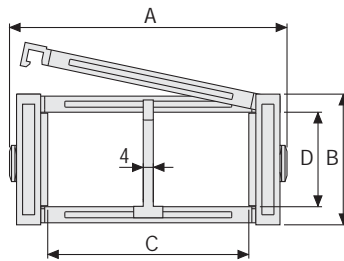

Separator	
- Unassembled	Part.no S308C
- Assembled	Part.no S308CMC
Pin	
	Part.no PG308

Technical characteristics when self-supported

Speed	8 m/s
Acceleration	40 m/s ²

For higher requirements please consult our technical dept.

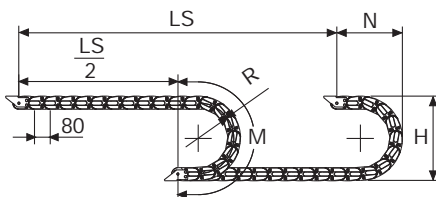

Length of chain (L)
Half travel distance ($\frac{LS}{2}$)
plus length of curve (M)

$$L = \frac{LS}{2} + M$$

A	B	C	D	R	Weight/m	Chain
mm	mm	mm	mm	mm	kg	Part Number
82	75	38	57	150-180-200-230-280-400	2,90	SR308CI(CE)038□□□*
93	75	49	57	150-180-200-230-280-400	3,01	SR308CI(CE)049□□□*
107	75	63	57	150-180-200-230-280-400	3,19	SR308CI(CE)063□□□*
113	75	69	57	150-180-200-230-280-400	3,27	SR308CI(CE)069□□□*
127	75	83	57	150-180-200-230-280-400	3,43	SR308CI(CE)083□□□*
132	75	88	57	150-180-200-230-280-400	3,48	SR308CI(CE)088□□□*
139	75	95	57	150-180-200-230-280-400	3,56	SR308CI(CE)095□□□*
149	75	105	57	150-180-200-230-280-400	3,67	SR308CI(CE)105□□□*
157	75	113	57	150-180-200-230-280-400	3,77	SR308CI(CE)113□□□*
168	75	124	57	150-180-200-230-280-400	3,91	SR308CI(CE)124□□□*
182	75	138	57	150-180-200-230-280-400	4,06	SR308CI(CE)138□□□*
207	75	163	57	150-180-200-230-280-400	4,36	SR308CI(CE)163□□□*
232	75	188	57	150-180-200-230-280-400	4,65	SR308CI(CE)188□□□*
243	75	199	57	150-180-200-230-280-400	4,78	SR308CI(CE)199□□□*
257	75	213	57	150-180-200-230-280-400	4,94	SR308CI(CE)213□□□*
284	75	240	57	150-180-200-230-280-400	5,25	SR308CI(CE)240□□□*
293	75	249	57	150-180-200-230-280-400	5,37	SR308CI(CE)249□□□*
344	75	300	57	150-180-200-230-280-400	5,95	SR308CI(CE)300□□□*
366	75	322	57	150-180-200-230-280-400	6,20	SR308CI(CE)322□□□*
394	75	350	57	150-180-200-230-280-400	6,11	SR308CI(CE)350□□□*

*Complete the code by inserting the value of the radius (R): Ex. SR308CI(CE)105 □ □ □ □

R	H	N	M
mm	mm	mm	mm
150	375	270	635
180	435	300	725
200	475	320	790
230	535	350	885
280	635	400	1040
400	875	520	1420



Self-Supporting Capacity Diagram

The maximum length of the self-supporting capacity ($\frac{LS}{2}$) in relationship to the weight of the cables and hoses contained per linear metre.

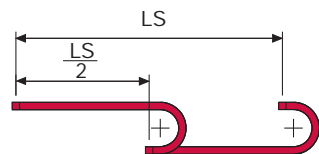
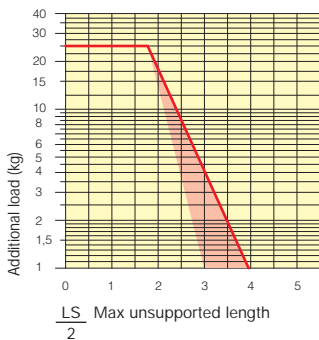

The red marking in the diagram area considers the difference of weight between various widths of chains assembled with nylon frames every second pitch.

For applications with $\frac{LS}{2}$ and weights not included in the area of the diagram showing self-supporting capacity, verify the possible use of support rollers (see page 30).

End Brackets

The end brackets set allows the two ends of the chain to be attached to the equipment.

Nylon Type

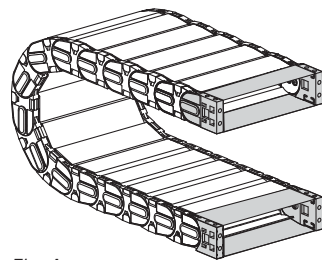

Fig. A
The chain can be fixed frontally, inner or outer radius. (Fig A)

Bright Zinc Plated Steel Type*

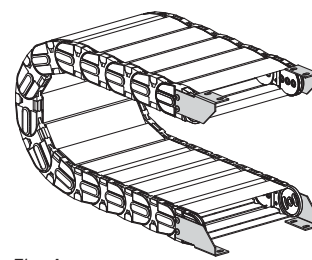
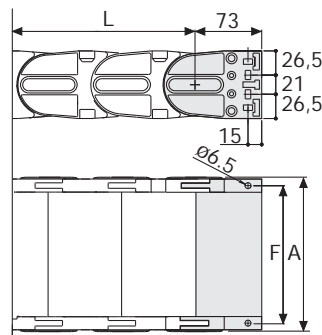

Fig. A
Chain fixed outside the radius. (Fig A)
See end brackets mounting variations page 31.



Chain Type	F mm
SR308CI(CE)038	62
SR308CI(CE)049	73
SR308CI(CE)063	87
SR308CI(CE)069	93
SR308CI(CE)083	107
SR308CI(CE)088	112
SR308CI(CE)095	119
SR308CI(CE)105	129
SR308CI(CE)113	137
SR308CI(CE)124	148
SR308CI(CE)138	162
SR308CI(CE)163	187
SR308CI(CE)188	212
SR308CI(CE)199	223
SR308CI(CE)213	237
SR308CI(CE)240	264
SR308CI(CE)249	273
SR308CI(CE)300	324
SR308CI(CE)322	346
SR308CI(CE)350	374

Nylon Type Part Numbers

Complete Set Assembled Chain Type	End Brackets Set
SR308	AN308C□□□KM

Complete Set Unassembled Chain Type	End Brackets Set
SR308	AN308C□□□K

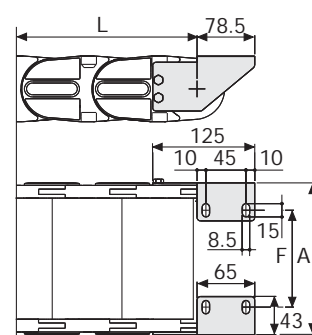

Chain Type	F mm
SR308CI(CE)038	20
SR308CI(CE)049	31
SR308CI(CE)063	45
SR308CI(CE)069	51
SR308CI(CE)083	65
SR308CI(CE)088	70
SR308CI(CE)095	77
SR308CI(CE)105	87
SR308CI(CE)113	95
SR308CI(CE)124	106
SR308CI(CE)138	120
SR308CI(CE)163	145
SR308CI(CE)188	170
SR308CI(CE)199	181
SR308CI(CE)213	195
SR308CI(CE)240	222
SR308CI(CE)249	231
SR308CI(CE)300	282
SR308CI(CE)322	304
SR308CI(CE)350	332

Bright Zinc Plated Steel Type Part Numbers

Complete Set Assembled Chain Type	End Brackets Set
SR308	A308CU□□□KM□**

Complete Set Unassembled Chain Type	End Brackets Set
SR308	A308CU□□□K□**

*Available on request in stainless steel
** 1=Pos.1; 2=Pos.2; 3=Pos.3
See end brackets mounting variations page 31.

Serie Protection

SR308CI SR308CE

Nylon Protection Cable Chain with openable aluminium covers